



ALEXANDRIA PETROLEUM  
MAINTENANCE CO.

# Training Plan



2016 - 2017

- اعداد القوائم المالية وفقا لمعايير المحاسبة المصرية
- مهارات التخطيط والرقابة الفعالة
- تنمية مهارات التخطيط الادارى
- سياسات الافراد وتنمية الموارد البشرية
- مهارات الرقابة والمتابعة الفعالة
- اعداد اللوائح والقرارات والمذكرات القانونية
- خطايات الضمان
- السكرتارية المتميزة وحفظ الوثائق والمستندات
- النظم الفعالة للاجور والمرتبات والحوافز
- مهارات الاشراف الفعال
- مهارات ادارة الوقت والتفويض
- مهارات وصف وتحليل وتقييم الوظائف واعداد الهياكل التنظيمية
- مهارات ادارة العلاقات العامة والاجتماعات والبرتوكول والاتيكييت
- المهارات السلوكية للمديرين
- تنمية مهارات التأثير الادارى
- مهارات العرض والتقديم
- مهارات التعامل مع الاخرين
- الاتصال والعرض والتقديم
- تنمية المهارات والقدرات الذاتية لتحسين الاداء الادارى
- الاساليب التحليلية والابتكار لحل المشكلات واتخاذ القرارات
- مهارات ادارة الازمات
- محاور التمييز الادارى
- مهارات التعاقد وادارة العقود
- ادارة المشتريات والمخازن وتخطيط الاحتياجات
- معالجة ضغوط وصراعات العمل
- مهارات بناء فرق العمل الفعالة
- المحاسبة المالية لغير المحاسبين
- مهارات المحاسبة فى شركات البترول
- مهارات اعداد وكتابة التقارير
- التخطيط الاستراتيجى
- مهارات الادارة الحديثة
- الاعمدة السبع للمدير المتميز
- تقييم العروض والمفاضلة بين الموردين





## M-Management Courses

- M01- Train The Trainer**
- M02- Strategic Talent Management in the Oil and Gas Industry**
- M03- The Middle Manager Development Programme: Creating Future Leaders**
- M04- Creative Strategic Planning & Leadership**
- M05- Personal Effectiveness & Influencing Skills Communicate, Negotiate, Influence & Persuade**
- M06- Setting Priorities, Time Management & Stress Reduction: Managing Stress & Pressure at Work**
- M07- Dynamics of Leadership**
- M08- Internal consultancy skills at work**
- M09- Maintenance & Reliability Best Practices: Lowering Life Cycle Cost of Equipment**
- M10- Maintenance Strategy Development and Cost Effective Implementation**
- M11- Root Cause Failure Analysis**
- M12- Modern Maintenance Technologies: Challenging Traditional Approaches in Maintenance**
- M13- Managing Efficient Shutdowns & Turnarounds**
- M14- Optimizing Equipment Maintenance & Replacement Decisions**
- M15- Economic & Technical Evaluations in Engineering & Maintenance Projects**







## P-Planning Course

- P01-Projects Management Professional (PMP)**
- P02- Program Management Professional**
- P03- Certified Business Analysis Professional (CBAP)**
- P04- PMI Risk Management Professional**
- P05- PMI Scheduling Professional**
- P06- Primavera 6**
- P07- Microsoft® Project 2010**
- P08- Petroleum Project Economics & Risk Analysis**
- P09- International Oil & Gas Business Management**





## Instrument & Control Courses

**I01-Pneumatic, Electro-Pneumatic & Hydraulic Systems, Design, Operation & Maintenance**

**I02-Industrial Process Measurement**

**I03-Flow Meters Calibration and Troubleshooting**

**I04-Crude & Gas Metering System**

**I05-Level Measurement and Automatic Tank Gauging**

**I06-Analytical Instrumentation in OnLine Applications**

**I07-Advanced Process Control**

**I08-Integrated Control Systems**

**I09-Practical Alarm Management System**

**I10-Safety Instrumentation and Emergency Shutdown System**

**I11-Distributed Control Systems 'DCS' operation maintenance and troubleshooting**

**I12-Programmable Logic Controllers (PLCs)**

**I13-SCADA Systems for Process control**

**I14-Boiler Control and Instrumentation for Engineers and Technicians**

**I15-Functional Specifications for PLCs, DCSs and SCADA systems**

**I16-Instrumentation Installation in Hazardous Areas and Equipment Selection**

**I17-Tuning of Industrial Control Loops**





## Instrument & Control Courses

I18-Practical Fundamentals of OPC

I19-Control Valve Sizing, Selection and Maintenance

I20-Safety Relief Valves: Inspection, Operation and Troubleshooting

I21- Fire and Gas Detection systems

I22-Field Bus System: Architecture, Configuration and Applications

I23-Industrial Data Communication System

I24-Applying Standard Instrumentation and Control Documentation

I25-Selection, Calibration, Maintenance and Troubleshooting for Field Devices and Control Systems

I26-Practical Hazop, trips and alarms

I27- Preparation for Functional Safety Certification “FS Engineer”

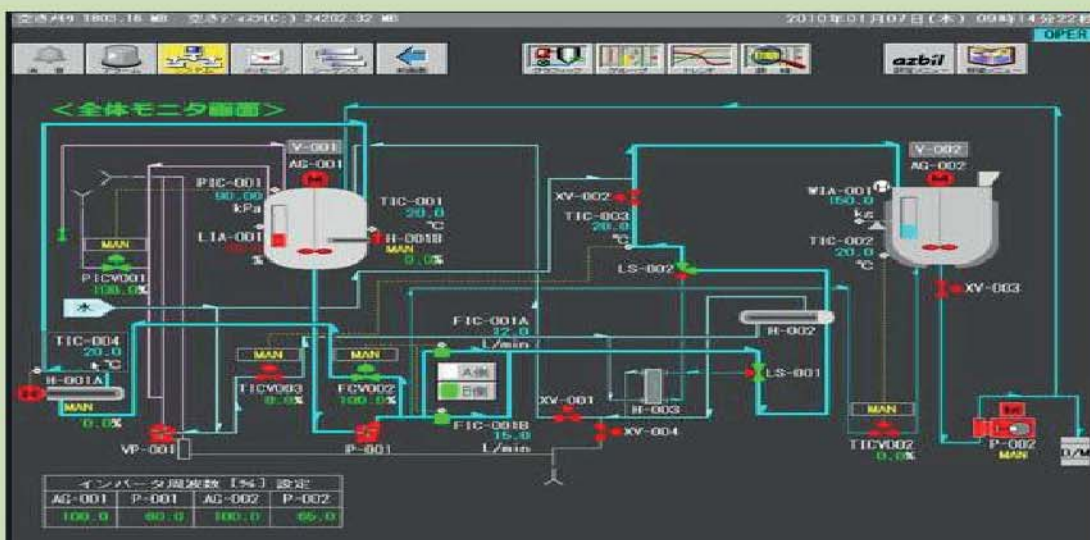





## E-Electrical Courses

**E01-Electrical Maintenance**

**E02-Electrical Motors**

**E03-Electrical Power Transformer**

**E04-Electrical Generators**

**E05-Batteries, Battery Chargers and UPS systems**

**E06-Electrical protection systems**

**E07-Electrical Control Devices**

**E08-Switchgears and Motor control Centers**

**E09-Electrical Installation in Hazardous area**

**E10-Electrical Cables Selection, Sizing, Rout, Sections & Inspection**

**E11-Electrical Lighting System in Hazardous areas**

**E12-Electrical High Voltage Techniques**

**E13-Electrical Protection Systems of electrical assets**

**E14- Generator Excitation Systems & AVR Selection, Commissioning, Operation, Maintenance, Testing & Troubleshooting**

**E15-Electrical Equipment & Systems (Installation, Troubleshooting & Maintenance)**

**E16-Electrical safety**

**E17-Grounding in Electrical Systems & Noise Reduction in Instrument Loops**

**E18-Variable Speed Drives Protecting & Increasing the Performance**

**E19-Uninterruptible Power Supply (UPS) Installation, Operation & Troubleshooting**





## E-Electrical Courses

**E20-Power factor correction and Harmonics Filtering**

**E21-Batteries Running Safety & Maintenance of Battery Systems**

**E22-Power Quality Problems & Troubleshooting**

**E23-Lightning & Surge Protection**

**E24-Reading Electrical Drawings & Schematics**

**E25-Electrical Engineering Basics (Technical Manager)**

**E26-Electrical Engineering Fundamental**

**E27-Electrical Power System for Electrical Technician**







## HV-Heavy Courses

**HV01- Applied Failure Analysis**

**HV02-Diesel GeneratorBasics**

**HV03-Diesel Generator Malfunction and trouble shooting**

**HV04-Heavy Equipment Power Train Fundamentals**



## AU-Automotive Courses

**AU01- Advanced injection systems in Gasoline & Diesel Engines**

**AU02-Air brake system maintenance in Heavy Trucks**

**AU03-Automatic gear boxes in modern vehicles**

**AU04-Defensive Driving Safety Training**

**AU05-Modern Vehicles Safety & Comfort Features Technologies**

**AU06-Vehicle Systems Mechanisms Introduction**





## IN-Inspection Courses

- IN01-API510-Pressure Vessels Inspector Preparation Course API510
- IN02-API570-Piping Inspector preparation Course API570
- IN03-API571-Damage mechanisms
- IN04-API577-Welding Inspection & Metallurgy
- IN05-API580-Risk Based Inspection
- IN06-API653-Tank Inspector Preparation Course API653
- IN07-C1-ASME B31.3 Process piping
- IN08-C2-AWS D1.1 Code; Structural Steel Welding Code
- IN09-C3-ASME31.1 Power & Process Piping
- IN010-C4-ASME Section IX (Welding & Brazing WPS, PQR, WPQ)
- IN011-C5-Boilers & Pressure Vessels ASME VIII (Design, Fabrication and Inspection)
- IN012-C6-Overview of API (Knowledge API1104 for Pipelines API650,653 for Storage Tanks- API510 for Pressure Vessel Inspection)
- IN013-C7-General Mechanical Codes and Standard and Specification Course
- IN014-C8-ASME Code Section V;Nondestructive Testing (NDT)
- IN015-MM39-AWS D1.1 Code; Structural Steel Welding Code
- IN016-NDT01-Radiographic Testing (RT) Level I & II
- IN017-NDT02-Ultrasonic Testing (UT) Level I & II
- IN018-NDT03-Magnetic Particle Testing (MT) level I & II
- IN019-NDT04-Dye Penetrate Testing (PT) level I & II
- IN020-NDT05-Visual Inspection (VT) level I & II
- IN021 -NDT06 -Eddy Current Testing (ET) Level I & II





## IN-Inspection Courses

- IN022 -NDT07 -Inspection & NDT Fundamentals
- IN023 -PL01 -Piping Design (Specification &Sizing)
- IN024 -PL02 -Pipeline Construction
- IN025 -PL06 -Pipeline Inspection, Maintenance, Repair
- IN026 -PL07 -Pigging and Smart Pigging
- IN027 -W01 -Certified Welding Inspector (CWI); Preparation Course
- IN028 -W02 -CSWIP 3.1 Preparation Course
- IN029 -W03 -CSWIP 3.2.2 Preparation Course
- IN030 -W04 -Welding Technology for Basic Welding Process
- IN031 -W05 -WPS, PQR, WPQ Overview & Preparation and Electrodes Selection
- IN031 -W06 -Welding Metallurgy and Heat Treatment
- IN032 -W07 -Material Testing Evaluations
- IN033 -W08 -Material Selection, Receiving and Review of Mill Test Certificates







## ME-Mechanical Courses

- ME01 - Fundamentals of Mechanical Engineering
- ME02 - Mechanical Engineering Basics for Technical Staff
- ME03 - Pumps And Compressors (Mechanical)
- ME04 - PUMPSTypes,Construction,Operation & Maintenance
- ME0 5- Centrifugal PumpsTheory, Operation & Maintenance
- ME0 6-Centrifugal Pump Workshop
- ME0 7- Machine Alignment & Balancing
- ME0 8- Mechanical Seals Technology
- ME0 9- Compressors and BlowersSelection, Operation and Maintenance
- ME 10- Compressors Tec hnology Basics for Technicians
- ME 11- Reciprocating Compressors Construction Operation and Maintenance
- ME 12- Centrifugal Compressors Theory, Performance, Operation & Maintenance
- ME 13- Advanced Centrifugal Compressor Technology Theory and Practice
- ME 14- Turbo Expanders (operation & maintenance)
- ME 15- Diesel Engines Construction, Operation & Maintenance
- ME 16- Reciprocating Gaseous Fuel Engines
- ME 17- Refrigeration and Air Conditioning For Engineers (Level 1)
- ME 18- Refrigeration & Air Conditioning FoEngineers (Level 2)
- ME 19- Refrigeration And Air Conditioning For Engineers (Level 3)
- ME20 - Refrigeration & Air Conditioning For Technicians
- ME21 - Absorption Chillers For Engineers





## ME-Mechanical Courses

- ME22 - Air Cooled Exchangers For Engineers (Level 1)
- ME23 - Industrial Cooling Systems (Technical & Economical Feasibility Study)
- ME24 - Heat Exchange Equipment Operational Performance & Maintenance
- ME25 - Insulation & Refractory
- ME26 - Turbo-Machinery Monitoring and Problem Analysis
- ME27 - Vibration Protection Systems for Turbo-machinery
- ME28 - Basic Vibration for Technicians
- ME29 - Vibration Instruments and Conditioning Monitoring Systems
- ME30 - Bearing & Lubrication Technology
- ME31 - Rolling Bearings
- ME32 - Machinery Components Maintenance and Repair
- ME33 - Valves Fundamentals
- ME34 - Manual Valves (Advanced)
- ME35 - Mechanical Power Transmission
- ME36 - Hydraulic Circuits Theory, Components, & Practice
- ME37 - Hydraulic Equipment Operation, Maintenance & Troubleshooting
- ME38 - تشغيل و صيانته الاوناش و معدات الرفع-
- ME39 - Furnaces Technology
- ME40 - Fundamentals Of Gas Turbine Operation & Maintenance
- ME41 - Advanced Course In Gas Turbine Operation & Maintenance
- ME42 - Steam Generation & Boilers Operation and Maintenance
- ME43 - Process Vessels







## **ME-Mechanical Courses**

**ME44 - Gaskets**

**ME45 -Measuring tools**

**ME46 - Hand Tools , Power Tools , Measuring Tools &Fasteners**

**ME47 -Pipe work and joints**

**ME48 - Energy Saving & Managements In Thermal Equipments**

**ME49 - Safety Rules And Environmental Standards In Thermal Equipments  
Operations**

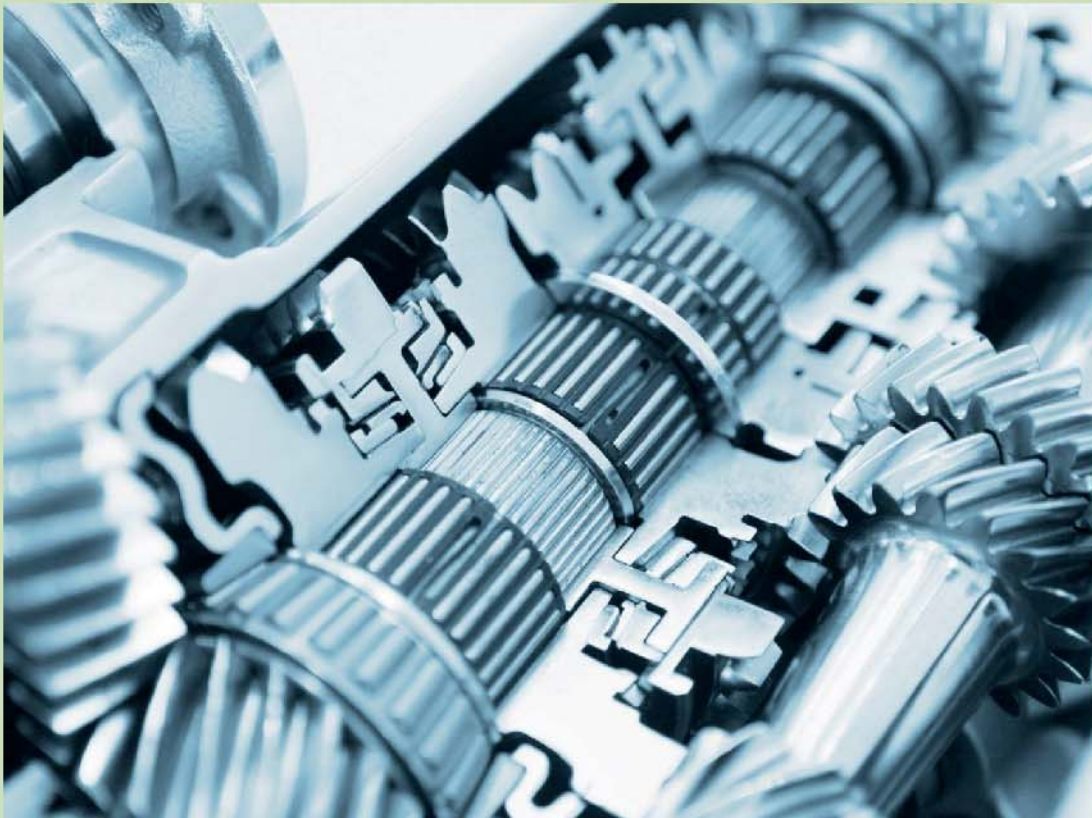





## PR-Processing/ Production Courses

- PR01- Water Treatment Systems**
- PR02- Process Safety and Hazard Analysis (PHA &HAZOP)**
- PR03- Process Operations for Technicians**
- PR04- Hydrocarbon Storage, Shipping and Utilization**
- PR05- Fire Heater & Heat Transfer Equipment**
- PR06- Process Calculation and Simulation : by HYSYS**
- PR07- Oil & Gas Field Processing**
- PR08- Oily Water Treatment**
- PR09- Mass and Heat Balance in Petroleum Industry**
- PR10- Oil and Gas Separation Equipment**
- PR11- Gas Processing, Plant Troubleshooting & Startup**
- PR12-Gas Dehydration Technology**
- PR13- LPG Technology**
- PR14- Natural Gas Processing Technology**
- PR15- LPG, NGL & LNG Production and Handling**
- PR16- Crude Oil Processing and Desalting**
- PR17- Oil Refining Technology**
- PR18-Bulk Measurements and Accounting Loss Reduction**
- PR19-Combustion Techniques**
- PR20-Flare & Over Pressure Protection Systems**
- PR21-Furnace Operations outlines**
- PR22-Oil Movement, Storage & troubleshooting**





## PR-Processing/ Production Courses

**PR23-Process Troubleshooting and problem solving**

**PR24-Shutdown & Turnaround Planning & Management**

**PR25-Surface Facilities Equipment -Advanced**





## L- Laboratory Courses

- L01- Modern Oil and Gas Laboratory Management: Effective Management of analysis support**
- L02- Laboratory Quality Management (ISO 17025:2005) in Oil, Gas and LNG Plants:SOP, Accreditation, Documentation and Auditing**
- L03- Oil and Gas field Production Chemicals and Additives:Theory, Selection, Application and Troubleshooting**
- L04- Advanced Process Gas Chromatograph Analyzers:Operation, Application, Maintenance and Troubleshooting**
- L05- Gas Chromatography Operation, Application, Troubleshooting, Maintenance & Method Validation (Practical Approach)**
- L06- Good Laboratory Practice (GLP): Quality Control and Calibration of Lab Equipment**
- L07- Cooling Water Treatment Technology**
- L08- Atomic Absorption Spectroscopy (AAS)**
- L09- Boilers Water Treatment**
- L10- Reverse Osmosis Techniques (RO)**
- L11- Cooling Water Treatment Technology**
- L12- Advanced Course in Corrosion Control in Oil, Gas and Petrochemicals Production fields**
- L13- Corrosion Control and Monitoring fundamentals for Technicians**







## Q- Quality Assurance and Quality Control

**Q01- Introduction to Six Sigma**

**Q02-Continual Improvement Assessment (CIA) using Lean thinking and Six Sigma methodologies**

**Q03-Statistical Process Control (SPC)**

**Q04-Integrated Management systems (IMS)**

**Q05-Introduction to Quality Engineering**

**Q06-Root Cause Analysis**

**Q07-Certified Quality Auditor (CQA)**

**Quality  
Assurance**



## S-Safety Course

- S01- Risk Assessment Techniques "HAZOP & HAZAN"**
- S02- Loss Prevention**
- S03- Risk Management**
- S04- HSE Management System**
- S05- Management of Hazardous Materials**
- S06- Hazardous Area Classification**
- S07- Emergency Plane & Response**
- S08- Accident Investigation**
- S09- Fires from First principles**
- S10- Safety Auditing**
- S11- Electrical Safety**
- S12- Environmental Impact Assessment**
- S13- Fire theory, protection and control**
- S14- HAZMAT Managing of chemical releases**
- S15- Loss Prevention Leadership**
- S16- Corrosion Problems and their Solving in Firefighting Loops**
- S17- برنامج الامان و السلامة فى عمليات الرفع-**
- S18- Safety At Laboratories**
- S19- Safety At Workshops (Hand and Portable Power tools )**
- S20- السلامة فى اعمال قطع و اللحام و الثقب على الساخن-**
- S21- Safety Of Portable ladders and scaffoldings**
- S22- Job Hazard Analysis & Risk Calculation**





## S-Safety Course

S23 - القيادة الامنه و سلامه اوناش الشوكه- S23

S24 - Fire Fighting Pumps Theory, Construction, Operation and Maintenance

S25 - Integrated Management Systems (IMS) for Safety Specialists

## HSE-Certified Safety Courses & Diploma

HSE01 -QHSE Professional Diploma (SPD)

HSE02 -Sport Management Diploma (SMD)

HSE03 -Professional QHSE Manager (PSM)

HSE04 -Certified QHSE Compliance Inspector (SCI)

HSE05 -QHSEMS Lead Auditor

HSE06 -Certified Risk Assessor (CRA)

HSE07 -Certified Incident Investigator (CII)

HSE08 -Certified Emergency Responder (CER)

HSE09 -Certified Lifting Inspector & Planner (CLIP)

HSE10 -Certified Scaffold Inspector (CSI)







## WL-Wire line Courses

**WL01- Wireline Operations.**

**WL02- Advance Wire line course**

**WL03- Wellhead Operations Maintenance & Testing**

## O-Offshore Courses

**O01- Introduction To Offshore Oil And Gas Platforms**

**O02- Steps For Building An Offshore Platform**

**O03- Special Features Of Offshore Platforms Projects**

**O04-Structural Engineering of Offshore Platforms**

**O05- Under Water Steel Structure Inspection & Repair**

**O06- Offshore Pipelines Engineering & Construction**





## R- Reservoir Engineering

**R01- Applied Reservoir Engineering**

**R02- Basic Reservoir Engineering**

**R03- Basic Well Test Analysis**

**R04- Production optimization using NODAL analysis**

**R05- Water flooding Design, Operations and Monitoring**

**R06- PVT Analysis & Equation of State for Compositional Simulation**

**R07- Reservoir Simulation**

**R08- Formation Damage, Causes and Prevention**

**R09- Modern Well Test Analysis**

**R10- Reservoir Management**

**R11- Reservoir Characterization**

**R12- Hydraulic Fracturing**

**R13- Well Stimulation & Hydraulic Fracturing Technology**

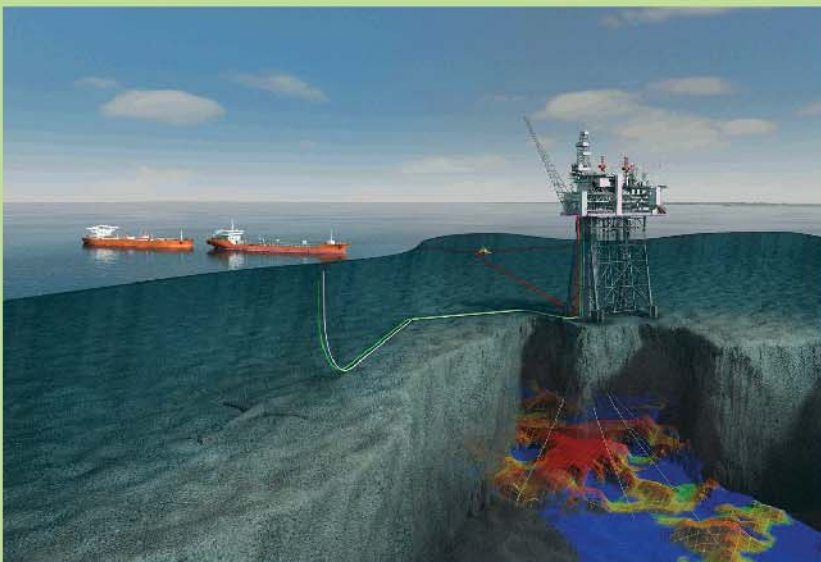



## D- Drilling Courses

- D01- Basic Drilling Technology**
- D02- Drilling Calculations**
- D03-Drilling Principle & Practice**
- D04- Casing &Cementing**
- D05- Drilling Problems**
- D06- Stuck Pipe and Fishing Operation**
- D07- Basic Direction and Horizontal Drilling**
- D08- Basic Well Control**
- D09- Well Operations Safety (Drilling) IWCF**
- D10- Well head Maintenance**
- D11-Inspection and audit for drilling rigs**
- D12- Introduction to completion design**
- D13-Fishing operations**
- D14- Drilling Fluids**
- D15- Coiled Tubing Design and Operations**







## MT-Material Coding Courses

- MT01- Modern Coding Systems Program Level (I)**
- MT02- Modern Coding Systems Program Level (II)**
- MT03- Modern Coding Systems Program Level (III)**
- MT04- Modern Coding Systems Program (Practices)**
- MT05- Coding Systems Program for Requesting Departments**
- MT06- Coding Systems Program for Advanced Level**
- MT07- Coding Systems Program for Store Keepers**
- MT08- Coding Systems Program to serve the maintenance programs**





## TC-Telecommunication Courses

**TC01- Optical Fiber Systems and Cables**

**TC02- Wireless Communication Systems**

**TC03- Microwave Communications**

**TC04- Mastering in Microwave Communications**

**TC05-Planned Maintenance of Telecommunication systems**

**TC06-Mastering in Optical Fiber Systems and Cables**

**TC07- PABX Systems**

**TC08- اساسيات الاتصالات السلكيه واللاسلكيه (I)**

**TC09- اساسيات الاتصالات السلكيه واللاسلكيه (II)**

**TC10- Biological Electromagnetic Effects and Safety Limits**



## **M-Management Courses**

M01-Train the Trainer

M02- Strategic Talent Management in the Oil and Gas Industry

M03- The Middle Manager Development Program : Creating Future Leaders

M04- Creative Strategic Planning & Leadership

M05- Personal Effectiveness & Influencing Skills Communicate, Negotiate, Influence & Persuade

M06- Setting Priorities, Time Management & Stress Reduction: Managing Stress & Pressure at Work

M07- Dynamics of Leadership

M08- Internal consultancy skills at work

M09- Maintenance & Reliability Best Practices: Lowering Life Cycle Cost of Equipment

M10- Maintenance Strategy Development and Cost Effective Implementation

M11- Root Cause Failure Analysis

M12- Modern Maintenance Technologies: Challenging Traditional Approaches in Maintenance

M13- Managing Efficient Shutdowns & Turnarounds

M14- Optimizing Equipment Maintenance & Replacement Decisions

M15- Economic & Technical Evaluations in Engineering & Maintenance Projects



# **M01- Train The Trainer**

## **Introduction**

This exciting and innovative course will provide participants with the latest scientific and best practices in workplace training and presenting. This course is paced, challenging and highly rewarding. Delegates will learn about adult learning, review design and delivery and have the opportunity to participate in a highly interactive and engaging programme.

The highly skilled course leader will lead from the front, demonstrating the techniques and allowing delegates to experience them first hand. Coaching will be provided to all delegates as an aid to self-development but also as a tool they can transfer to their own training sessions.

- A focus on adult learning & training principles
- Focus on the latest techniques and strategies for effective workplace learning
- Understand your own and others learning style
- Practical steps in developing a presentation with the minimum of difficulty
- Understand the limitations and appropriate use of PowerPoint™ and other training technologies
- How to manage nerves when presenting or training

## **Objectives**

By the end of this course participants will be able to:

- Evaluate training techniques used in presenting (evaluation)
- Describe the training cycle and its application to training and development (knowledge)
- Discuss andragogy in relation to adult learning (comprehension)
- Differentiate between the various methods of evaluating training (analysis)
- Calculate a training cost benefit (application)
- Design a training outline utilizing Blooms taxonomy for educational objectives (synthesis)

## **Training Methodology**

Participants to this course will receive a thorough training on the subjects covered by the seminar outline with the Tutor utilising a variety of proven adult learning teaching and facilitation techniques. Seminar methodology includes stimulating presentations supporting each of the topics together with interactive trainer lead sessions of discussion. Role-plays, small group work, videotaped presentation exercises and feedback will be used to facilitate learning.

There will also be two practical sessions where participants will give a presentation and receive immediate coaching and feedback from the Tutor and the group. These presentations will be given to the participants on a USB drive to take home and use for further reflection and evaluation.

## Organisational Impact

By attending this exciting course you will be investing in your future, the future of your Department and the future of your Organisation.

- Add value to the department and the organisation as a whole
- Participants will be left with a range of skills and competencies to train staff effectively
- Incorporating taught skills and techniques into work behaviour, participants will demonstrate practical training skills
- Attending this course will allow delegates to understand precisely how to train others
- Participants are encouraged to take new ideas and strategies back to their workplace for discussion with their managers
- Following this course the organisation will have an enthused trainer

## Personal Impact

Participants on this exciting course will develop their skills and knowledge of training. You will leave the course with:

- Detailed knowledge of training, learning & development
- Improved confidence and self-assurance
- A greater appreciation of the psychology of adult learning
- The ability to handle nerves when presenting
- A greater awareness of adult learning & training principles as it relates to your work
- An increased ability to design training programmes

## Who Should Attend?

This course is for anyone involved in training planning, delivery or those who wish to develop their training and presentation skills. It is suitable for a wide range of people but will particularly suit:

- Those working in or transferred to a training, learning and development role
- Managers wanting to develop staff and their training
- Experienced training, learning and development staff who want to refresh their skills
- Anyone responsible for the training of others
- Anyone involved in talent management, Nationalisation programmes, business partnering or skills transfer

## Programme Outline

Day 1 - The Role and Function of a Training

- Why do we need to train anyone?
- The role of training
- The training cycle
- How adults learn: andragogy
- The Conscious Competence Model

- Practical workshop: assessing your personal learning style

## Day 2 - Exceptional Presentation Skills

- Presentations without fear
- Stylistic elements of presenting
- Audiovisual techniques
- Cultural issues
- Handling questions
- Practical workshop: Videotaped presentations, coaching & feedback

## Day 3 - Training Needs Analysis (TNA) & Learning Objectives

- What is training needs analysis?
- Identifying and meeting learning needs
- Step-by-step guide to building a presentation
- Understanding learning objectives
- Learning strategies
- Practical workshop: Writing objectives using bloom's taxonomy

## Day 4 - Advanced Presentation & Training Skills

- Restricting PowerPoint™ to enhance communication
- Communication is not all about body language
- Our brain cannot cope with too much information at one
- Practical workshop: use of small groups in training
- Brainstorming: you may have been doing it wrong
- Practical workshop: Videotaped presentations, coaching & feedback

## Day 5 - Writing Training Materials & Training Evaluation

- Writing Training Materials
- Steps in the writing process
- Material (Facilitator, Trainer & Presentation)
- What is training evaluation?
- Kirkpatrick's Levels of Evaluation
- Practical workshop: Calculating a Cost-benefit



## **M02- Strategic Talent Management in the Oil and Gas Industry**

### **Introduction**

Never, in this highly competitive and unstable economy, has managing and retaining talent been more important for the oil and gas industry. Losing or not being able to recruit the best talent can have a disastrous impact on an organization's growth and sustainability. On this highly-interactive seminar you will learn about key talent management processes, systems and procedures and how to apply these in the multi-complex and diverse industry that is Oil and Gas.

You will gain insight into talent identification methods, grading structures, competency/behavioural frameworks, the effective use of psychometric tools and other assessment methods. Having identified your talent or high potential, you will learn about the optimum development options, ensuring the effective focus of talent in the organisation.

In addition, you will understand and develop succession plans to ensure positive career paths and development for talent and high potential employees, so securing sustained growth of the organisation.

The seminar will highlight:

- New perspectives and understanding of talent management and high potential identification
- Aligning Business Strategy and Talent Management in the complex multi-discipline Oil and Gas industry
- Process and systems to identify, develop and retain your talent and high potentials
- Development strategies to ensure your talent and high potential achieve their optimum performance
- Succession planning as a key differentiator in an organisation's success and how this is achieved
- Strategic direction to optimize your talent and high potential pipeline in your organization to provide continued sustainable growth

### **Objectives**

In this program you will learn to:

- Define talent, talent management, high potential and succession planning
- Identify and create development strategies to optimize your talent and high potential
- Understand, develop and employ talent strategies within the complex multi-discipline oil and gas industry
- Design and develop effective succession planning strategies
- Lead and manage OCR (Organisational Capability Review) meetings to ensure your organisation's growth

## Training Methodology

The seminar will combine tutor-led presentations with interactive experiential exercises and case studies. Delegates will be encouraged to participate actively in relating the principles of talent management and high potential development to the particular needs of their workplace.

## Organisational Impact

Leaders and managers of talent within their organization:

- Have the ability to understand and relate to people in the organization
- Provide the mechanism for sustainable growth of the business
- Possess the skills and development aptitude to ensure the growth of individuals to achieve their maximum potential
- Create and drive the strategy to make individuals and the organisation outstanding

## Personal Impact

This seminar teaches the competencies that enable leaders to:

- Identify, develop and retain high potential and talented people
- Understand and formulate higher level strategy to drive their organisation's growth
- Analyse complex personal data, models and theories using subjective and objective processes
- Improve their ability to communicate, influence and work with others
- Build and effectively develop better people in a sustainable way.

## Who Should Attend?

This program will greatly benefit individuals, within or aligned to the oil and gas industry, who wish to develop their leadership knowledge and skills in strategically managing, developing and retaining talent and high potential people:

- Professionals
- Managers
- HR personnel

## Programme Outline

Day 1 - Defining and attracting talent in the oil and gas industry

- Talent Management – overview and background
- Talent / High potential – defining the criteria
- The complex dimensions of oil and gas demographics
- Talent options – recruit external – or grow internal?
- Aligning Talent Management with Organisational Development (OD) and Business Strategy
- Utilising Workforce Planning and other sources of data
- Attraction strategies – use of media and other channels

## Day 2 - Creating your High Potential Talent Pool

- Talent management models, grading and structures
- Assessment methods and systems – use of Psychometric/Behavioral/Competency frameworks
- Conducting an effective Talent Gap Analysis
- ABC model of Potential – getting the criteria right
- Using the 9 Box Grid, and other methods to create your talent and high potential matrix

## Day 3 - Developing your Talent and High Potentials

- Defining high caliber development options
- Conducting an effective performance discussion
- Creating individual development plans
- Powerful feedback techniques: motivating individuals to achieve higher potential
- Coaching for success

## Day 4 - Retaining and Sustaining your Talent and High Potentials

- Career paths – guidance for growth
- Using mentoring programmes to develop and retain your talent
- Reward strategies – intrinsic and extrinsic incentives to motivate your talent
- Managing expectations and delivering workable outcomes
- Growth rotation development (assignments, experience strategies)
- Creating a sustainable talent pipeline

## Day 5 - Strategic Succession Planning and Organisational Capability Review

- Defining your bench strength
- Succession Planning and the OCR process
- Conducting effective Calibration Meetings
- Formulating a strategic talent plan for the organization in line with the Business Strategy
- Communicating the Strategy to the Board and the Company
- Conclusion and Review



## **M03- The Middle Manager Development Programme: Creating Future Leaders**

### **Introduction**

Many middle professionals have a wealth of experience at handling day to day management issues and are now ready for a bigger challenge. Are there extra skills they need to acquire to prepare them for the next level of leadership? This programme is about exploring and mastering those skills and knowledge that will comfortably take you to the next level of competence – from professional to leader.

It will give you a real insight into what drives individual behaviour, how to pinpoint the cultural style of your organisation and understand its inherent cultural strengths and weaknesses. We'll explore team dynamics in the context of the culture, look at functional and dysfunctional behaviour and how dysfunctional behaviour can be reshaped. We'll explore how easy it is for the leader to unwittingly set people up for failure and how this can be avoided. We'll investigate motivation, reward and getting the best from the team.

Finally you will spend time planning action what you want to change when you return to your workplace.

- Make the transition from management to leadership
- Learn the tools of influence
- Understand behaviours at work
- Explore corporate culture
- Learn to lead and motivate your team

### **Seminar Objectives**

By the end of this programme you will have learned to make the transition from professional to leader by:

- Ensuring that you have all the core skills of effective management and leadership
- Understanding what drives individual behaviour and how to motivate and reward excellence
- Truly understanding the culture of your organisation
- Exploring team dynamics and discovering your own preferred team roles
- Having a framework for implementing successful change programmes

### **Training Methodology**

We use a variety of accelerated learning techniques to help to embed learning and enhance recall where it really counts – back in the workplace. Any theory discussed will be grounded immediately in practical day to day work. Methods will include “freeze-frame” role plays, case studies and self-assessments, and other practical activities based around real working scenarios. Learning will be enhanced through active involvement in exercises followed by review. Opportunities for self assessment will be provided and feedback on individual and group performance will be

encouraged. Participants will have opportunities to work on their own individual team issues during the programme.

### **Organisational Impact**

The organisation will benefit from having middle managers who are:

- Motivated and confident to move up to the next level
- Able to avoid common pitfalls at the more senior level through greater understanding of corporate culture
- Equipped to make a significant contribution to moving the organisation in desired directions and steer teams through complex situations
- Thinking and acting like leaders

### **Personal Impact**

Participants will:

- Gain new insights into their preferred leadership style and learn how to be flexible in both leadership and management
- Be able to “read” behaviour and use that understanding in creating a motivating environment for their staff
- Understand their own and others’ preferred team roles
- Be able to influence upwards in the organisation with confidence
- Be able to plan and lead change

### **Who Should Attend?**

This seminar is designed for:

- Those who have some experience at supervisor / professional level and are ready to take on a wider role
- Those who want to make the transition from competent professional to inspirational leader
- Those who need a deeper understanding of what drives individual behaviour and group dynamics
- Those who need to hone their influencing skills to get results that matter
- Those about to embark on leading a change programme within their organisation

### **Programme Outline**

Day 1 - Core Skills required for managing a team

- Delegating effectively
- Goal Setting – S.M.A.R.T. goals
- Performance Appraisals that work
- Introducing a new employee to the job
- Coaching and on-the-job training
- Giving Praise effectively

- Constructive Confrontation skills
- Saying 'No' skillfully
- Counselling for performance improvement
- Disciplinary Process
- Dealing with grievances
- Discipline procedures`
- Dealing with difficult colleagues

## Day 2 - Understanding People

- Individual characteristics that influence behaviour
- Personality styles and traits
- Attitudes and behaviour
- Perception in the workplace
- Attributing causes to behaviour
- Types of workplace behaviour

## **Organisational Culture**

- The organisational cultural web
- Types of organisational culture
- Developing organisational culture
- Managing organisational culture
- Changing organisational culture
- Group Think – How an unhealthy culture develops and how to prevent it
- Signs of a healthy organisational culture
- Effects of a healthy organisational culture

## Day 3 - Team Dynamics

- Group Dynamics
- Team Roles – A Self Perception Inventory
- Team roles and complementarities
- Team formation and dynamics
- Functional and dysfunctional group behaviour
- The set up to fail syndrome
- Inter-team relationships

## **Getting The Best From Your Team**

- What are people looking for in their jobs? Do their managers know?
- The basic motivational process
- Ironies of motivation
- Managing People – ten essential behaviours
- How do you rate on motivating?
- Motivation techniques for greater commitment & output
- Reward systems in high performance work systems
- How to reward and inspire your team



- Team rewards
- Creating energy in the team
- Knowledge workers and the psychological contract
- Receiving feedback and criticism
- Helpful hints for providing feedback and criticism

#### Day 4 - Influencing Upwards In The Organisation

- The Individuals Needs Framework
- The Six Key Weapons of Influence and how to use them
  - Constancy & Escalating Commitment
  - Reciprocation
  - Need to be like others
  - Warming to
  - Power
  - Short supply
- The Five Styles of Decision Makers and how to distinguish them:
  - Charismatics
  - Thinkers
  - Controllers
  - Skeptics
  - Followers
- Selecting strategies and dialogues for each decision making style
- Matching Appropriate Influencing Principles to Decision Making Style
- The Trigger Words that appeal to each Decision Making Style

#### Leadership That Inspires

- The difference between Management & Leadership
- Leadership and emotional intelligence
- The effects of different leadership styles on organisational climate
- Comparing management with visionary leadership
- Characteristics of visionary leaders
- Characteristics of a good vision statement
- Communicating your vision
- Leaders who are effective at communicating their vision and inspiring people
- Ethical political behaviour
- Trust orientation profile

#### Day 5 - Managing Change Successfully

- Sources of resistance to change
- Preventing resistance and encouraging effectiveness in coping with change
- Choosing a strategy to implement change
- The steps in a successful change programme
- Membership of the team leading change
- Communicating change – the steps involved
- Mastering the art of speaking as a change leader

- Sustaining change efforts

### **Action Planning**

- What have I learned about leadership that I want to apply back on the job?
- Can I paint a compelling picture of success?
- How should I go about implementing it?
- What barriers might I come up against and how might I overcome them?
- Who might be my allies and how do I build their commitment?
- When will I start and when will it be implemented?

## **M04- Creative Strategic Planning & Leadership**

### **Introduction**

This seminar is designed to provide leaders and professionals with a set of transformational tools and techniques to help them maximise their own and their team's creative potential in a strategic context. Its starting-point is self-discovery: participants will work on the inside first and then focus outwards to impact on the world of business.

The focus of the first week of this 2-week seminar will be on thinking in different ways. Participants should be prepared to move out of their comfort zone and experiment with new ways of creating and communicating an inspiring leadership vision.

The second week helps demystify the frequently-misunderstood concept of 'strategy'. Rather than viewing strategy as an academic exercise, it centres on strategic planning as a value-adding process which harnesses the leader's and the team's creativity and enables ideas to be nurtured through to reality.

### **The highlights of the 10-day seminar are as follows:**

- Demonstrating how to balance analytical and creative thinking in plans and decisions
- Understanding how to discover and focus the creative capabilities of teams and individuals
- Understanding the linkage between operational and strategic management
- Aligning your own responsibilities and objectives with the strategy of your organisation
- Improving personal leadership and management competencies

### **The seminar is split into two modules:**

**MODULE I** – Leading Creatively

**MODULE II** – Strategy & Strategic Planning

Each module is structured and can be taken as a stand-alone course; however, delegates will maximise their benefits by taking Module 1 and 2 back-to-back as a two-week seminar.

### **Seminar Objectives**

By the end of this programme you will be able to:

- Demonstrate innovative methods for harnessing others' creative potential
- Communicate your vision in refreshing and engaging ways
- Define the concepts of 'strategy' and 'strategic plans'
- Understand and explain visionary thinking as part of the strategic process and apply strategic planning to your own management issues



- Place your own part of the organisation within the overall context of corporate strategy
- Gain confidence in managing your own contribution to strategic implementation

### **Training Methodology**

This seminar uses a range of approaches to learning, including experiential group activities, individual visioning exercises, case studies and syndicate discussions, to allow you to see and feel for yourself the power of the creative mind in a strategic context. Formal inputs are used to introduce a limited amount of underpinning theory. A key part of the learning process is sharing the differing experiences participants bring, as well as experimenting with novel – and sometimes challenging – techniques.

### **Organisational Impact**

- Leaders at all levels who can develop and communicate a shared vision
- Leaders who can engage and motivate their teams
- Increased effectiveness against personal KPI's through more effective use of team
- Much better decision-taking and time/resource allocation – leading to better organizational and individual performance
- Introduction of strategic thinking into new levels of the organization
- Top management having more confidence in the ability and judgement of its operating managers and the staff will have a better appreciation of the need and content of organisational change

### **Personal Impact**

- Increasing career flexibility (vertically and horizontally)
- Accelerated thinking speed and problem resolution for difficult dilemmas
- Improved understanding of the impact of operational specialisation on corporate strategy
- Improved team working capabilities in analysing and solving strategic problems creatively
- Improved skills in ensuring most effective impact of individual specialisations
- Greater motivation through multiple organisational levels

### **Who Should Attend?**

- Senior Management Professionals, Team Leaders, Supervisors and All Professionals who are responsible for driving company growth by creating or eliciting new ideas and paradigms. Alternatively, you may be stuck with your own 'logical' career journey and seeking an opportunity to explore beyond its boundaries.
- Anyone who wants to forge innovative approaches to communications, or to human resource and training managers searching for breakthrough ideas and tools they can use to harness the creativity in others within their organisation.

### **Programme Outline**

#### **Day 1 - Creative Problem-Solving**

- Leadership Reality Assessment

- Leadership Vs Management
- Understanding Our Brain Function
- Myths of Creativity
- The limitations of the rational
- Divergent approaches to problem-solving
- Letting go of logic
- Analogous thinking modes
- Convergent and divergent modes

## Day 2 - Overcoming Personal Blockers to Creativity

- Sigmoid Curve – Lifecycle Model
- Continuous Improvement
- Breakthrough step change
- Self-awareness and the nature of the ego
- Personal goal alignment
- Adaption and innovation: personal preferences for creating meaning
- Exploring attitudes to risk
- Left- and right-brain thinking

## Day 3 - Developing the Vision Creatively

- Six thinking hats
- Using differing thinking styles
- JoHari's window
- The business plan process & creating a vision
- Harnessing the power of the team
- Organisational culture and its influence on innovation
- Letting go of the ego
- Working with different creative preferences

## Day 4 - Communicating the Vision Creatively

- The 7 Step Creative Process
- Models of communication
- Viral visioning
- Authenticity and trust
- Creativity tools, techniques & strategy
- Letting go of the vision
- Leading without directing
- Possible leadership beliefs

## Day 5 - From Ideas to Action: Creativity and Change

- Motivation – Hierarchy of Needs
- Overcoming organisational barriers to creativity and change

- Nurturing a learning environment
- Is Money a motivator?
- Personality Profiling
- Building a creative consensus
- Engaging stakeholders creatively
- Influencing and motivating through change

#### Day 6 - Strategic Thinking and Business Analysis

- What are strategy and strategic planning?
- Why are strategy and strategic planning important?
- What are the main conceptual frameworks?
- External analysis – understanding and analyzing business attractiveness – macroenvironmental factors, growth drivers, competitive forces, market dynamics
- Benchmarking your own strategic position/competitor analysis
- Analyzing customers
- “Thinking backwards from the customer”
- Mini-case on importance of external analysis

#### Day 7 - Internal analysis and fusion of analyses into strategic options

- The interface of external and internal analysis
- Internal analysis: financial
- Internal analysis; non-financial
- The concept and practicalities of the “balanced scorecard”
- Diagnosing strategic problems and opportunities
- Fusion of analyses into strategic choices – SWOT and the strategy matrix
- Case examples of strategic choice
- Mini-case on importance of internal analysis

#### Day 8 - Strategic plans and the relevance of alliances and joint ventures

- Review of the tools used so far
- The content of a strategy: avoiding “paralysis by analysis”
- Putting a strategic plan together – the 5-page framework
- A real-life example of a business strategy/strategic plan
- Strategies for alliances and joint ventures
- Example of best practice in alliances and joint ventures
- Introduction and briefing for the main case study
- First-phase group work on the main case study

#### Day 9 - Global strategy, teambuilding and the management of internal communication

- The essence of globalization and global strategy
- Globalization – the strategic dimension
- Globalization – the organizational dimension



- Globalization – the human dimension
- How to build and manage a strategic planning team
- Communicating strategy through the organization
- Gaining your team's commitment and buy-in to the strategy
- Second-phase work on the main case study

#### Day 10 - Strategic implementation and getting the value out of strategy

- Final-phase work on the main case study
- Group presentations of the main case study
- Effective execution – converting strategic analysis and planning into action
- Linking strategy with operational objectives
- Implementation – getting practical things done
- Strategic planning of your own career
- Creating tomorrow's organization out of today's organization
- Conclusion – the corporate and individual value of strategic thinking

## **M05-Personal Effectiveness & Influencing Skills** **Communicate, Negotiate, Influence & Persuade**

### **Introduction**

This seminar focuses on areas of communication and persuasion which will help delegates to be more effective in the organisational context. By understanding the key concepts of internal communication and how these skills contribute to influencing and persuading others in the organisation, delegates will be able to turn more outcomes in their favour.

The following are the highlights of the programme:

- Understand communication and persuasion and what impact they have on an organization's ability to function.
- Be able to use communication and influence to improve an organization's productivity, profitability, morale, etc.
- Increase self-awareness and develop the skills to deal confidently and professionally with colleagues and customers.
- Learn how to speak eloquently and convincingly.
- Be able to prepare and deliver strong and persuasive speeches and presentations.

### **Seminar Objectives**

By the end of this programme, delegates will be able to:

- Tap into their personal strengths in communicating and know when to invoke different methodologies
- Understand ways of influencing others without resorting to power-plays and applying direct pressure
- Persuade other people by the use of pro-active, win-win strategies
- Draw upon professional communication and presentation skills to create a winning impression in discussions and meetings
- Plan and prepare businesslike presentations with ease and be able to tap into key decision makers during and after the presentation

### **Training Methodology**

The seminar is designed as a highly interactive series of sessions that build on the Delegates' current skills and experience. Communication and Presentation practice is handled using Real-Play; a system like role-play but using Real World examples and people. At all times, the facilitator will draw on real world Work-experience as well as Leadership Theory to bring points to life.

### **Organisational Impact**

Organisations can expect delegates to:

- Return to work with new found confidence in internal communication
- Proactively represent the Company in presentations and key-note addresses in their key fields
- Plan and prepare more effective meetings, presentations, communications and briefs
- Make better and quicker decisions and be able to communicate the benefits more clearly
- Communicate more effectively and with better understanding of their verbal and nonverbal impact on others

## Personal Impact

Delegates can expect to:

- Increase their natural communication style and start to enjoy communicating
- Plan and prepare more professional presentations, meetings and communications
- Find it easier to influence and persuade others
- Recognise the impact of negotiation gambits used by themselves and others and how to turn them to their advantage
- Understand their preferred communication style and the impact of their vital non-verbal signals

## Who Should Attend?

- Senior Leaders
- Senior and Middle managers
- Project Managers
- Key communicators
- People who need to communicate and present more effectively in their role
- Employees with a specific development need to influence and persuade other people more effectively

## Programme Outline

Day 1 - Personal Inner Communication Essentials

- What is Communication?
- What does effective Communication mean?
- Understand the 3 major levels of Communication
  - Intra- Personal (with Oneself)
  - Inter-Personal (with another Individual)
  - Inter-Active synergy (with a group of persons)
- Appreciate the different 'fields of experience'
- Discover the power of Non-Verbal Communication
- Study the 8 Non-Verbal empowerments
- Understand why your personal Self-Image has a great deal to do with your presentation, language, style and content
- Controlling your subconscious mind to communicate effectively

## Day 2 - Understanding Communication and Persuasion

- Understanding the communication cycle
- Analyse the Communication Pyramid
- Know the power of words in the communication process
- Discover the powerful I-A-D-A communication format
- Understanding the brain, during the communication process
- Understand the keys to successful public speaking
- How to develop and present a vital speech
- How to dress professionally and appropriately
- Find out the right and wrong ways in body posture
- How to use your voice effectively
- Discover the power of illustrations and stories
- Learn how to overcome Public speaking fears
- How to listen actively and respond accordingly
- Know the power of influence

## Day 3 - Communicating and Presenting Effectively

- Learn how to organize your presentation
- How to prepare and present a computer / Power Point presentation etc
- What to do prior to a presentation
- Understand the impact of Visual communication
- Understand the psychology of the Smile in communication
- How to present to a cross-cultural audience
- Observe what features attract an audience
- Learn how to analyse your audience
- Using positive visual imaging
- How to use the telephone effectively and professionally

## Day 4 - Communication Strategies for Professional Excellence

- How to an effective decision maker, in the communication process
- How to use strategic communication negotiation skills
- Discover the 9 Keys to making an effective presentation
- Learn how to develop a systematic filing system
- Learn how to obtain good source material

## Day 5 - Applying Personal Influence and Persuasion

- Analyse the 9 strategic principles for effective communication
- Apply these Communication principles into a “Plan of Action” for your life and incorporation into your Company infra-structure
- How to be proactive and make things happen
- Essential communication practices for ongoing success



## **M06- Setting Priorities, Time Management & Stress**

### **Reduction: Managing Stress & Pressure at Work**

#### **Introduction**

In an ever increasing pace of Life and Business, it becomes even more important to remove stress and operate with heightened sensory acuity.

Firstly, most people deny that they are stressed or affected by internal or external factors.

Secondly, the most important thing that you have is not Money or other things, it is TIME, You can't save it, you can't stop it, and you will run out of it so why not learn how to use it properly. As the cost of stress to the employer continues to grow, organizations must recognize stress in their employees and train management to manage stress productively. A recent survey showed that 1 in 5 people report their work to be very or extremely stressful, citing the nature of their work, relationships at work or their employer as the cause.

This seminar will teach you:

- The latest psychological techniques to manage stress including psychological techniques to stop internal voices, anxiety and worrying.
- Identify and deal with the causes of stress and how time affects you and others
- How to resolve inner conflict and reduce negative internal dialogue
- How apply efficient strategies for success in any area of life
- Release your full potential and achieve well-formed goals continuously

#### **Seminar Objectives**

In this seminar, delegates will be able to:

- Actively identify and reduce stress in themselves and others
- Develop ways of Managing the most Important element – TIME
- Take charge of your state of mind
- Maximizes performance and motivation at work
- Improve health and happiness
- Have a positive economic impact on individual and team performance
- Use NLP to change the way you think

#### **Training Methodology**

The most up to date Psychological Training methodology is used to present this seminar. The 4MAT System is used to create an environment of Performance. The seminar is carefully designed to address all styles of learning and to engage participants fully. Lectures and discussions are either preceded or followed by powerful individual or group exercises, relaxations and therapeutic interventions.

These exercises provide opportunities for personal participation in real situations. During these exercises you discover that you can do what you are learning. This process makes the training fun filled, challenging and empowering.

### **Organisational Impact**

- Stress is an individual physical response to a given stimulus and therefore everyone responds differently in different situations. What is acceptable for one person can be extremely stressful for another.
- Only by providing employees with a clear understanding of why they feel stress, and providing them with the ability to do something about it, can companies hope to truly protect their employees.
- This program introduces delegates to the close relationship between mind and body, how physical responses are influenced by thinking patterns, and how personal conditioning can lead to stress, task avoidance, and even phobic reactions.
- Delegates are shown how to take charge for their own well being rather than relying on the company or other people. Delegates are then shown how to apply these skills with their team.
- This training seminar provides delegates with the skills and strategies to play a leading role in reducing team stress.

### **Personal Impact**

- Reduction of stress is a unique stress management program. It addresses problems caused by stress, by providing delegates with practical solutions for dealing with stress in any situation.
- Each delegate will develop their own set of resources to deal and eliminate stress in seconds.
- Learn to reframe situations and always see the positive.
- Remove stress and heighten your sensory acuity.
- Delegates learn how to relax, regain control and focus on taking personal ownership and Responsibility for their state of mind and achieve positive outcomes to any situation.

### **Who Should Attend?**

- All Professionals
- Supervisors
- Personnel Professionals
- Training Professionals
- Occupational Health Specialists
- Health and Safety Professionals
- Employees on any organisations that demands more from them, anyone that has to manage stress and pressure at work, meet deadlines and deliver results.

### **Programme Outline**

#### **Day 1 - Managing Your Job**

- Managing yourself and the resources at your disposal
- What are you and your team trying to achieve?

- Defining your objectives and key result areas
- Establishing responsibilities and priorities

### **Practical Time Management & Planning Activities**

- Effective use of diaries, time planners, time logs, etc.
- Criteria for prioritising – urgent and important
- Planning and scheduling your activities
- Dealing with interruptions and distractions – staying focused
- Managing time under pressure
- Developing a proactive approach to short, medium and long term plans

### **Day 2 - Managing Yourself**

- Investing time and effort in order to achieve more in the future
- Your time management behaviour – preferred working styles
- Personal effectiveness – a guide to self-discipline
- Highlighting personal 'time-stealers' and areas of weakness

### **Managing Others & Meetings**

- Managing people managers, colleagues, team members and customers
- Getting more things done through assertive behaviour
- Making the most of meetings as participant or chairperson

### **Effective Delegation**

- The rules of effective delegation – overcoming personal preferences and prejudices
- Using delegation as a means of coordinating the workload of your team/department

### **Delegation**

- Freeing up your time
- Developing staff

### **Ongoing Self-development**

- Reviewing your management of time at regular intervals?
- Overcoming your old habits – maintaining your new standards?

### **Day 3 - Communicating with Excellence Getting Results**

- The Rules of Communication – overcoming personal attitudes. Stereotypes, Prejudices and Beliefs
- Why people do what they do and Influencing for Results

### **Managing Pressure in the Workplace**

- Moving from reactive to proactive
- Working to priorities when everything is urgent

- Taking control through planning and time management
- Managing conflicting demands from more than one person

#### Day 4 - Understanding Stress and its Causes

- What is stress? – Recognising the physical and behavioural signs, Stress in the mind and body
- What contributes to workplace pressures? – The top ten causes
- The impact of stress on personal performance – the positive and negative effects of stress
- Recognising the signs of stress in ourselves
- Maintaining an effective balance between home and work
- How gaining control of your Mind can reduce or eliminate stress
- The symptoms of short term and long term stress
- Recognizing your individual stress response and that of others
- Learning to recognize your stress level and key stressors
- The major causes of stress at work and at home
- How to develop self belief to overcome stress
- When stress aids performance and when stress detracts from performance

#### Day 5 - Different Stress and Behavioral Patterns

- Learning behaviour types: passive, aggressive, passive aggressive and assertive
- How conscious and sub-conscious thinking affects behaviour
- Developing self-assertiveness to achieve greater control over stress
- Improving your communication skills to manage aggression, stress and conflict from others

#### **Handling Stress Positively, a Positive Mindset**

- Stress handling strategies for you and your team
- Maintaining an effective balance between home and work
- Changing your mindset – seeing the positive side of change in the workplace
- Motivating yourself and others under pressure
- Developing a preventative rather than remedial approach to team problems



## **M07- Dynamics of Leadership**

### **Introduction**

This seminar will help you define and implement the vision you have for yourself, your term and your organisation. Working from an initial understanding of your own capabilities, motivators and resources, it will build an action plan for moving you and those around you towards a shared perception of the future, able to respond to an ever-changing world.

Highlights include:

- Understanding the leader's dynamic context
- Self-awareness and self-belief as drivers of leadership behaviours
- Adopting the appropriate 'altitude' as a leader
- Developing a robust and engaging vision
- Building key alliances inside and outside the team
- Maximising returns on investment in the team

### **Seminar Objectives**

- Examine your personal style and drivers of behaviour
- Analyse the interpersonal forces at work in your team and organisation
- Develop a vision for realising your personal and organisational goals
- Inspire your team with a dynamic and aligned statement of purpose
- Identify and develop key partners in achieving your shared vision
- Link personal, team and organisational goals for sustainable performance

### **Training Methodology**

The programme will combine presentations with facilitated discussions, interactive practical exercises, small-group activities and case studies. A key element in this process is to learn from each other's ideas, so **all** contributions are valuable. A psychometric instrument will be used to generate a personality profile, which will contribute to your understanding of your preferences and personal style.

### **Organisational Impact**

Leaders at all levels who can respond effectively to change are better able to adapt to the dynamic and unpredictable context all organisations face over the longer term. Organisational performance depends on the ability of managers to stand back from their everyday pressures and scan the bigger picture, while retaining the confidence and trust of their team and colleagues; this seminar will help them do this.

## Personal Impact

Participants will be exposed to a range of perspectives on the leadership function, sharing examples of best practice and challenging some assumptions about the role of the manager. The seminar will ask you to examine your beliefs about yourself and the contribution you can make to your organisation over the longer term, and develop an action-plan to make your vision a reality.

## Who Should Attend?

Team Leaders and senior professionals who would like to take a wider perspective on their organisation, their role and themselves, and prepare for a move into strategic positions

## Programme Outline

### Day 1 - Leadership and Transformation

- Leadership and its context
- Self-perception
- Personality values and behaviour
- Personal transformation and path dependency
- Limiting beliefs and how to overcome them
- Personal style and style flexibility

### Day 2 - Core Dynamic Competencies

- Leadership competencies
- Influence, authority and power
- Helicopters, satellites and drones
- Emotions, mood & disposition
- Rapport-building
- Communication: art or science?

### Day 3 - Developing a Dynamic Leadership Vision

- Strategic orientation
- Contextual awareness
- SWOT analysis
- Rationality and its limitations
- Goals and objectives
- Goal congruence and alignment

### Day 4 - Building Leadership Alliance And Teams

- Organisational dynamics
- Delegation and empowerment
- Organisational culture
- Creating a positive climate
- Developing the alliance through teamworking
- Team and individual development
- Motivating in times of change

#### Day 5 - Leadership and Life Balance

- Reassessing personal goals
- Balancing work, life and leadership
- Handling pressure
- Building a sustainable personal future
- Action planning
- Personal development planning

## **M08-Internal consultancy skills at work**

### **Introduction**

As business structures change, HR Professionals and other specialists are required to perform an internal consultancy role. This course covers the latest in accurate and informative material in relation to Internal Consultancy. An internal consultant is not the same as an external consultant and requires specific skills in communication, coaching and analysis. Typically the internal consultant is drawn from one of the teams of professional service providers where there is a history of supporting internal customers with specific problems. This course helps delegates develop the practical skills for internal consultancy in the workplace.

This course encourages delegates to:

- Understand and apply the consultancy process in the workplace
- Explore the theory and practice of Organisational Development (OD)
- Understand the application of work psychology to their workplace
- Manage change and prepare staff for change
- Develop skills related to data collection and analysis

### **Seminar Objectives**

- Develop internal consultancy skills
- Understand the application of Organisational Development (OD)
- Develop your communication, coaching and consultancy skills
- Apply motivational coaching techniques
- Understand Change and Change Management Principles
- Develop skills related to data collection and analysis

### **Training Methodology**

This Course will be presented in a highly inter-active manner, with a very engaging presentation style. DVD and video segments will highlight the major teaching features. A variety of Practical Sessions, Role Plays, and Case Studies are programmed into the seminar.

### **Organisational Impact**

- Well-equipped people to handle internal consultancy
- Improved stakeholder and consultant relationship
- Awareness of the importance of technical know-how for good consultants
- Delegates Able to ascertain and fulfil customers needs
- Manage customer expectations effectively

### **Personal Impact**

- Acquire consulting skills from start to finish of a project
- Develop interpersonal skills to communicate ideas, listen and provide support
- Ability to agree or disagree constructively to clients



- Able to ascertain and fulfil customers needs
- Cultivate coaching skills to train and develop others

### Who Should Attend?

- Professionals seeking to raise their consultancy skills
- All HR Staff interested in Internal Consultancy
- Team Leaders responsible for internal consultancy
- Technical professionals who wish to develop their internal consultancy and communication skills
- Individuals who desire to develop and facilitate internal consultancy projects

### Programme Outline

#### Day 1 - Developing your internal consulting skills

- The internal consultant's role
- How the internal consultant differs from line management and external consultancy
- The consultancy cycle
- Understanding what do your clients need from you
- Client readiness and capability
- Contracting
- Disengaging
- Case studies on Internal Consultancy

#### Day 2 - Coaching Skills for Internal Consultants & Managers

- What is Coaching and Coaching Boundaries
- Introducing Workplace Coaching Techniques
- Coaching Models
- Key Motivational Coaching Skills
- Limitations of Coaching
- Introduction to the psychology of development
- Key development principals
- Workshop – Coaching skills practice

#### Day 3 - Organisational Development (OD)

- The Psychology of Work
- History of OD
- Putting OD into practice
- The development of the modern organisation
- Organisational Structures
- The goals of data collection & research methods
- Data Analysis Practical Workshop

#### Day 4 - Effective Communication Skills for Coaching

- Introduction to the psychology of communication
- Understanding your personal communication style
- Language – verbal & non-verbal (body language)
- Listening skills
- Emotional Intelligence (EI) & Emotional Competencies
- EI – Giving Feedback Model
- Facilitation techniques & skills
- Workshop – Consultancy Techniques

#### Day 5 - Change Management

- Introduction to Managing Change
- Defining the scale of organisational change
- Approaches to Organisational Change
- People Factors that Influence the Change Process
- The Five Psychological Phases of Change Management
- The Pressure-Performance Relationship
- Overcoming resistance to change
- Developing your personal action plan

# **M09- Maintenance & Reliability Best Practices: Lowering Life Cycle Cost of Equipment**

## **Introduction**

Maintenance & Reliability Best Practices are critical for every successful individual and company. This workshop delivers many practical and new Maintenance and Reliability Best Practices concepts and tools. You will discuss these concepts and practice using practical tools in case studies and discussion groups.

The costs associated with equipment downtime and reduced production can be significant. Learning how to effectively manage all aspects of your industrial facility is a must. This workshop is a combination of instructor lead topic areas and class discussions. Interactive discussions will allow you to hear and learn best in class applications relating to maintenance planning and cost management strategies. You will have the opportunity to ask lots of questions in order to consider how best to apply these tools and techniques in your organisation.

- Maintenance best practice improves competitive position
- Initiatives such as Six Sigma & Lean depend on reliable equipment
- Technical and people aspects are fully covered
- Hard and soft copy of practical improvement tools are provided
- Important points are reinforced by workshop sessions

## **Seminar Objectives**

- Evaluate and justify your maintenance programs using Value = Benefit – Cost.
- Apply Life Cycle cost and risk planning to your facility assets.
- Target Maintainability and/or Reliability in the development of your facility maintenance plans.
- Learn the PLAN, DO, REVIEW cycle of continuous improvement.
- Apply the theory of this session using practical case studies.
- Practice using improvement techniques

## **Training Methodology**

This workshop is a combination of instructor lead topic areas and class discussions. Interactive discussions will allow you to hear and learn best in class applications relating to maintenance planning and cost management strategies.

## **Organisational Impact**

By sending your staff on this seminar you will achieve:

- Lower life cycle costs for equipment
- More reliable equipment
- Lower maintenance costs
- Better planning

- Improved team working between maintenance and production
- Increased equipment performance

### Personal Impact

- Strategies aligned to the business goals
- Introduction to the latest tools and techniques
- Exposure to best practices drawn from a range of different industries
- Methodology to enable successful permanent changes
- Application of the most appropriate reliability improvement technique
- Consideration of technical and human aspects of reliability improvement

### Who Should Attend?

It is highly recommended that all Maintenance, Reliability, Engineering and technical support staff including leadership and management attend this workshop.

- Planners
- Maintenance Supervisors
- Engineers
- Crafts and Tradesmen
- Reliability Engineers
- Operations Supervisors

### Programme Outline

#### Day 1 - Asset Cost Management Introduction

- Definitions of reliability, maintenance & asset management
- The total cost of maintenance
- Best practice reliability and maintenance processes
- Elements of asset management best practice
- Auditing performance
- Overview of TPM, RCM, BCM, QCM, and other asset management buzzword
- Open discussion sessions

#### Day 2 - Laying the Groundwork

- Team-work maintenance, operations, stores
- The importance of standards such as PAS 55, JA1011
- Corporate asset management expectations
- Asset performance expectations
- The forms of asset failure and degradation
- The causes and nature of asset failure and degradation
- The effects, cost and risks of asset degradation
- Practical Application and Open Discussion sessions



### Day 3 - Applying the Value based Process

- Breaking the cycle of failure and degradation
- Select PM tactics on the basis of costs and risks
- How to determine PM intervals
- Condition based maintenance types and the PF-curve
- The four important reliability functions
- Implementing best practice maintenance programs
- Optimising spares to support the maintenance program
- Maintenance program cost and risk based justification
- Practical Application and Open Discussion Sessions

### Day 4 - Ensuring the Continuity of the Value-based Process

- Complete the PLAN, DO, REVIEW Improvement cycle with FRACAS
- Failure Reporting, Analysis and Corrective Action System requirements
- Structure and code data collection to support reliability analysis
- How to quantify chronic failures and losses
- Use Pareto analysis and stratification to focus the value-based analysis
- Quantify losses in life cycle terms
- Hypothesise root causes of failure and verify on the basis of evidence
- Reliability Analysis Case Study
- Discussion of software and templates to support analysis

### Day 5 - Supporting Process that Lower Life-cycle costs

- Planning and scheduling best practice
- Cost effective man-power and skills deployment
- Performance indicators to drive continuous improvement
- Overall review of concepts learned

# **M10- Maintenance Strategy Development and Cost Effective Implementation**

## **Introduction**

Maintenance & Reliability Best Practices are critical for every successful individual and company. The first module of this workshop delivers many practical and new Maintenance and Reliability Best Practices concepts and tools. You will discuss these concepts and practice using practical tools in case studies and discussion groups. The second module then helps you decide in a rational way which activities are best done with internal resources and which are best outsourced. Tools and techniques are introduced which will help you ensure that outsourcing contracts are comprehensive and avoid the common pitfalls.

The costs associated with equipment downtime and reduced production can be significant. Learning how to effectively manage all aspects of your industrial facility is a must – so is this ten – day seminar.

The focuses of this seminar are highlighted as follows:

- Understanding Outsourcing methodologies
- Contracting types, including Service Level Agreements
- Risk Based Maintenance to ground maintenance contracts
- Dashboards and real-time performance monitoring and Key Performance Indicators to monitor performance
- Continuous improvement and performance management: how to evaluate the performance with all parties involved

**The seminar is split into two modules:**

**MODULE I – Maintenance & Reliability Best Practices**

**MODULE II – Maintenance Contracting & Outsourcing**

Each module is structured and can be taken as a stand-alone course; however, delegates will maximise their benefits by taking Module 1 and 2 back-to-back as a two-week seminar.

## **Seminar Objectives**

By the end of this seminar delegates will be able to:

- Evaluate and justify your maintenance programs using Value = Benefit – Cost
- Apply Life Cycle cost and risk planning to your facility assets
- Target Maintainability and/or Reliability in the development of your facility maintenance plans
- Learn the PLAN, DO, REVIEW cycle of continuous improvement
- Understand how to decide rationally what maintenance activities to outsource and what is not

- Learn the features, functions and benefits of lean maintenance contracts
- Understand the different types of maintenance contracts (incl. Service Level Agreements) and when/how to apply them
- Learn how to define service levels and monitor the contractor performance
- Learn how to develop and negotiate a maintenance contract
- Understand how to evaluate the delivered performance of all parties involved
- Learn how to implement maintenance contract management

### Organisational Impact

The seminar provides knowledge to understand maintenance and reliability needs and then outsource the optimum maintenance activities using effective maintenance contracts.

- Provide the tools to focus maintenance onto the most needy areas
- Use the latest best practices to develop your maintenance programme
- Provide instruments to improve maintenance contract management in both short as well as long term
- Ensure that you will get the most out of your maintenance contracts
- Avoid potential pitfalls regarding developing and managing maintenance contracts
- Saving time, money and irritation

### Personal Impact

- Strategies aligned to the business goals
- Introduction to the latest tools and techniques
- Exposure to best practices drawn from a range of different industries
- Methodology to enable successful permanent changes
- Gain understanding and practical insight of outsourcing and contracting aspects.
- Improve level of personal knowledge.

### Who Should Attend?

- Teams who have been assigned the responsibility to develop a maintenance strategy will find it extremely useful to attend this course as a unit
- All professionals negotiating, managing and verifying maintenance contracts
- Teams who have been assigned the responsibility of establishing a maintenance contract will find it extremely useful to attend this course as a unit
- Anyone who wishes to update themselves on Reliability, Maintenance, Maintenance Contracts & Outsourcing

### Programme Outline

#### Day 1 - Asset Cost Management Introduction

- Definitions of reliability, maintenance & asset management
- The total cost of maintenance
- Best practice reliability and maintenance processes
- Elements of asset management best practice

- Auditing performance
- Overview of TPM, RCM, BCM, QCM, and other asset management buzzword
- Open discussion sessions

## Day 2 - Laying the Groundwork

- Team-work maintenance, operations, stores
- The importance of standards such as PAS 55, JA1011
- Corporate asset management expectations
- Asset performance expectations
- The forms of asset failure and degradation
- The causes and nature of asset failure and degradation
- The effects, cost and risks of asset degradation
- Practical Application and Open Discussion sessions

## Day 3 - Applying the Value based Process

- Breaking the cycle of failure and degradation
- Select PM tactics on the basis of costs and risks
- How to determine PM intervals
- Condition based maintenance types and the PF-curve
- The four important reliability functions
- Implementing best practice maintenance programs
- Optimising spares to support the maintenance program
- Maintenance program cost and risk based justification
- Practical Application and Open Discussion Sessions

## Day 4 - Ensuring the Continuity of the Value-based Process

- Complete the PLAN, DO, REVIEW Improvement cycle with FRACAS
- Failure Reporting, Analysis and Corrective Action System requirements
- Structure and code data collection to support reliability analysis
- How to quantify chronic failures and losses
- Use Pareto analysis and stratification to focus the value-based analysis
- Quantify losses in life cycle terms
- Hypothesise root causes of failure and verify on the basis of evidence
- Reliability Analysis Case Study
- Discussion of software and templates to support analysis

## Day 5 - Supporting Process that Lower Life-cycle costs

- Planning and scheduling best practice
- Cost effective man-power and skills deployment
- Performance indicators to drive continuous improvement
- Overall review of concepts learned

## Day 6 - Outsourcing Considerations

- Introduction to program
- Introduction delegates
- Asset management
- The business impact of maintenance
- Considerations in outsourcing maintenance – what to outsource and what not?
- Activity on asset matrix
- Risks involved
- Case study: Outsourcing maintenance activities

## Day 7 - Maintenance Contracts

- Maintenance contract types
- Parties involved
- The tendering process – modern ways of tendering
- Choosing the right contractor
- Costing the service
- Defining Key Performance Indicators to monitor the performance of all parties involved
- Use of Balanced Scorecard with performance contracts
- Interactive exercise and examples

## Day 8 - Developing the Maintenance Contract

- Vendor management
- The contracting cycle
- Assemble a team
- Assess, determine and specify the required service levels
- Writing the contract – contents of a maintenance contract
- Interactive exercise: review some existing contracts
- Implementing contract management – how to make it work (performance management)
- Periodic evaluation & improvement

## Day 9 - Grounding and Negotiating the Contract

- Expectations about availability, reliability and costs
- The extensive preventive maintenance schedule – “tricks” of maintenance contractors
- The seven steps to develop a risk based maintenance concept
- Using the maintenance concept to negotiate more effectively lean maintenance contracts
- Negotiating the contract – negotiation ploys
- Negotiating the contract – negotiation tactics
- Negotiating tips



- Interactive exercise and role play regarding negotiating

#### Day 10 - Final Workshop

- Development of a maintenance contract in groups
- Defining the requirements and service levels
- Develop the offer
- Selection criteria
- Presenting the bid
- Closing the contract
- Evaluation of results
- Wrap-up

# **M11- Root Cause Failure Analysis**

## **Introduction**

The highly interactive Root Cause Failure Analysis program addresses a modern approach to problem solving in maintenance management. The program is based on some of the most recent research in the field. Participants will be enabled to improve the performance of their operation with practical, down-to-earth techniques that are based on first principles.

The following aspects will be addressed:

- Logistics of Continuous Performance Improvement
- Decision Logic and Operational Knowledge Types
- Maturity Indexing
- Relationship Development and Analysis
- Strategic Focus
- Complexity; Risk; and Variability Models

## **Seminar Objectives**

Applying the concepts taught in this programme, the student will be able to:

- Develop and implement a sustainable world class maintenance strategy
- Perform a systematic Root Cause Failure Analysis
- Develop an improved understanding of numerous maintenance environment variables, and of the relationships between them
- Understand, audit and optimize your maintenance process
- Understand the use and application of generic problem solving techniques
- Cascade the principles and benefits of the program to other employees

## **Training Methodology**

The training methodology is inter-active with numerous group exercises and is suitable for all employees involved in maintenance and operations management. The pace and level of the program is customized to the understanding of the delegates. Ongoing back-up and support is available after the program on request to the supplier, and the program is also available for in-house presentation as well as for “Competency Transfer” via a site license.

## **Organisational Impact**

- Improved Performance
- Informed decision-making
- Delegations and Productivity
- Focused activities
- Improved understanding of the maintenance process
- Elimination of Time-Wasting activities

## Personal Impact

- Improved decision making abilities
- Clarity of vision
- Understanding of Consequences (Cause / Effect)
- Improved Maturity
- A new sense of certainty and confidence
- Empowerment and a results driven focus.

## Who Should Attend?

- Engineering and Technical Professionals and Supervisors from any industry
- Maintenance Planners and Coordinators
- Operations and Manufacturing Professionals and Supervisors
- Foremen and Team leaders
- Plant Engineers and Maintenance System Professionals
- Section Engineers and Planners

## Programme Outline

### Day 1 - Problem Solving – Basic Principles

- Problem Identification Session
- Terminology of RCFA
- Decision Logic
- Three Knowledge Types
- Maintenance Maturity Indexing
- Six Level Generic Performance Standard
- Continuous Improvement
- Exercises

### Day 2 - Sustainable Maintenance Performance Improvement 1

- Introduction to Modern Maintenance Practice
- The SQC Performance Model
- Reverse Risk Analysis
- Maintenance /Operations Objectives and Resource Analysis
- Complexity; Risk; and Variability Models
- The Maintenance Cost Ratio
- Solving of Delegate Problems
- Exercises

### Day 3 - Sustainable Maintenance Performance Improvement 2

- Cross Referencing Operational Variables (Group Exercise)
- “Your Maintenance Costs are too High!”
- Sigma Sets: The Absolute Decision Standard
- Data / Knowledge Base
- Accuracy and Availability of Data / Cost relationship

- The Four critical stages of Data Maturity
- Logical Critical Thinking vs. Creative Lateral Divergent Thinking
- Case Studies: Analysis and Exercises

#### Day 4 - Root Cause Analysis

- Maintenance Strategy Development and Implementation
- Standard Pitfalls for Maintenance Improvement Initiatives
- Generic Problem Solving Techniques
- Logical Problem Solving Techniques
- Creative Problem Solving Techniques
- Other Problem Solving Techniques
- A Systematic Root Cause Failure Analysis Methodology
- Exercises

#### Day 5 - Action Plan Development

- Introduction to TRIZ Methodology
- Review of Most Suitable Techniques
- Development of an “Instant Approach” to Problem Solving
- Application of “Standard Questions”
- Individual Delegate Requirements
- Commercial Programs
- Logistical Requirements for Practical RCFA implementation
- RCFA Exercises (Analysis of Client Company Specific Problems)

# **M12- Modern Maintenance Technologies: Challenging Traditional Approaches in Maintenance**

## **Introduction**

Modern Maintenance Technologies provides all the delegates great opportunities to optimise the performance of their systems and equipment to achieve maximum return on investment (ROI). By reducing costs and downtime, while achieving high levels of safety and quality.

This seminar provides an overview of a number of Modern Maintenance Technologies associated with equipment, systems, people and management. It describes both the background to each technology, and its practical application to achieve the best bottom-line results.

This seminar introduces participants to the skills and knowledge areas of essential maintenance technologies and methodologies of today, such as:

- Asset Management : beyond maintenance management
- Cost/benefit thinking
- Understanding risk and an introduction to a Risk Based Maintenance approach
- Decision support tools to make maintenance more effective
- Root Cause Analysis (RCA)
- Understanding audits, maintenance assessments and benchmarking as a means to improve your maintenance management process.

## **Seminar Objectives**

The delegates will learn how:

- To apply the appropriate Modern Maintenance Technologies
- Each of these technologies contributes to maintenance efficiency
- These technologies can interact with and support each other
- To achieve the best results in practicing these technologies
- To develop an action plan to utilise these technologies in their own areas of responsibility, fitting them into the overall maintenance strategy, and measuring benefits

## **Training Methodology**

The seminar will be conducted along workshop principles with formal lectures, case studies and interactive practical exercises. There will be many opportunities for discussion and sharing experiences.

## **Organisational Impact**

- The organisation will understand modern maintenance technologies and methodologies.



- Learn fast how other companies are using modern methodologies to improve their maintenance performance.
- Gain insight in common pitfalls and key success factors.
- Know how to implement improvement actions successfully.
- The seminar provides the organisation with instruments to improve maintenance management in both short as well as long term.

### Personal Impact

- Gain understanding and practical insight of asset management and modern technologies and methodologies.
- Improve level of personal knowledge.
- Work more effectively by applying a risk based approach.
- Add value for themselves
- Be able to plan and develop a future career.

### Who Should Attend?

- Supervisors, Team Leaders and Professionals in Maintenance, Engineering and Production
- Anyone who wishes to update themselves on Modern Maintenance Technologies, judge the suitability of these technologies for their needs, and learn how to implement them for the benefit of their organisations

### Programme Outline

Day 1 - Introduction & Overview: challenging the traditional approaches to maintenance

- Introduction to program
- Introduction delegates
- Asset Management
- The business impact of maintenance
- Cost/benefit thinking: spending the right amount of maintenance
- Applying basic optimisation tools to support cost/benefit decisions
- Introduction to risk
- Video about maintenance & risk and interactive discussion

Day 2 - Risk Based Maintenance (RBM)

- Deterioration: the way assets could fail
- Representation of risk
- Not all failures are risky and must be prevented – applying risk to failures
- The seven steps of Risk Based Maintenance (RBM) – the methodology
- Failure Mode Effect & Criticality Analysis (FMECA)
- Failure behaviour
- Choosing the right maintenance task
- Interactive exercise

Day 3 - Root Cause Analysis (RCA)

- Multiple realities
- Interactive and exercise about subjective views
- Effective problem solving
- Preventing problems by finding the root causes of these problems
- Defining the problem as a starting point
- Cause and effect relations
- RCA methodologies – some examples and how to apply it in practice
- Case study

#### Day 4 - Process Audits, Maintenance Assessments & Benchmarking

- Where are we now – introduction to process audits, benchmarking & assessments
- Process audit – basic theory
- Interactive exercise – auditing in practice
- Maintenance assessment – basic theory
- Interactive exercise – execute a maintenance assessment of the work planning & control process
- Benchmarking – basic theory
- Some examples of benchmark studies
- Interactive exercise – how to interpret benchmark results

#### Day 5 - Performance Management & Decision support tools

- Defining performance
- Applying specific performance indicators and process parameters to measure the performance of assets, activities and processes
- Interactive exercise
- Performance management: the behaviour of people
- ABC-model of influencing the behaviour of people to gain better results
- Applying sophisticated decision support tools to optimise maintenance performance
- Case study
- Wrap up

## **M13- Managing Efficient Shutdowns & Turnarounds**

### **Introduction**

Planning and managing shutdowns, turnarounds and outages in the process plant environment is a complex and demanding function. If turnarounds are not properly planned, managed and controlled, companies run the risks of serious budget overruns, costly schedule delays and negative impacts on customers.

In this programme you will learn:

- How to develop a Shutdown/Turnaround strategy
- Management of all stages of the shutdown process
- Develop the management plan, work plans, resource plans and budget
- How to manage related issues such as risk and safety

### **Seminar Objectives**

By the end of this seminar delegates will be able to:

- To enhance the company's turnaround management capabilities, and to ensure a team approach in the planning and execution of plant shutdowns and turnarounds
- Provide a comprehensive understanding of effective turnaround management techniques and implementation
- Create awareness of planning methods and an integrated organisational approach in the execution of successful turnarounds
- Incorporate latest developments in turnaround planning and management techniques and emerging industry trends
- Develop an action plan to improve their own turnaround management techniques
- Have a much clearer understanding of their own and every other team members role in ensuring a successful turnaround

### **Training Methodology**

This workshop is a combination of dynamic instructor lead topic areas and class discussions. Interactive discussions will allow you to hear and learn best in class applications relating to shutdown and turnaround planning and execution techniques. The workshop ends in a practical application of theory in a team based case study.

### **Organisational Impact**

The organisation will benefit from this seminar by:

- Improved motivation of employees that are now more confident about how to go about planning managing their shutdowns and turnarounds
- Improved shutdown work quality and less rework
- Reduced shutdown durations due to the elimination of unnecessary work and proper scheduling
- Reduced costs due to the smoothing of resource demand and improved resource utilisation

- Fewer logistical delays due to improved planning and communication
- Lower risk due to formal risk management

### Personal Impact

The individual will benefit from this seminar by:

- A greater appreciation of the key role of planning in the shutdown process
- Being able to analyse, compile and communicate the initial scope and estimates with confidence
- A better understanding of how the shutdown/turnaround must support the current objectives of the organisation and plan accordingly
- Being able to recognise shortcomings in the current way of planning and scheduling and being able to actively contribute to improvement
- Becoming a more valued member of the team due to improved knowledge in all aspects of shutdown and turnaround management
- Improved self-esteem, confidence and a fresh outlook from exposure to quality training and also the opportunity to network with people from other organisations that face similar challenge

### Who Should Attend?

The seminar would undoubtedly be of immense value and interest to:

- Shutdown or turnaround professionals and coordinators
- Planning/scheduling and cost control staff
- Construction superintendents and supervisors
- Operations shutdown/outage coordinators
- Project engineers and contract administrators
- Participation from inspection, materials, safety and maintenance engineering is also encouraged

### Programme Outline

Day 1 - The Role of Maintenance Shutdowns and Turnarounds in World-class Organisations

- How shutdowns and turnarounds can contribute to the business
- Key success factors
- The three critical paths of shutdowns and turnarounds
- The difference between shutdowns and turnarounds and projects
- Shutdown and turnaround return on investment
- Shutdown and turnaround management self-assessment
- The shutdown and turnaround phases
- Reasons for shutdowns and turnarounds
- Success Factors

Day 2 - Shutdown/Turnaround Preparation

- Risk management

- Justification requirements
- Communications to stakeholders
- Shutdown roles and organisation
- RASCI matrix for shutdown
- Preparation critical success factors
- Identify routine PM to be included in scope
- Identify routine condition based tasks to be performed prior to shutdown and turnaround
- Identify function testing to be performed at conclusion of shutdown and turnaround

### Day 3 - Shutdown/Turnaround Preparation continued

- Apply CBM and degradation analysis to create scope visibility
- Apply notification process to manage create scope visibility
- Apply risk-based task selection methods to prioritise and challenge scope
- Review, approve, communicate and freeze the scope
- The critical outcomes of planning
- The 5 Ms of maintenance work quality
- Job analysis and scoping
- Estimating
- Risk and contingency planning
- The use of planning templates
- Work breakdown structure

### Day 4 - Shutdown and Turnaround Schedule

- Terms and concepts of scheduling
- Network display methods
- Apply CPM
- Identify resource constraints
- Resource requirements based on CPM
- Resource smoothing
- Resource balancing
- Optimised resource profile
- Shutdown and turnaround budgets
- Assign Shutdown Work – In-house and Contractors
- Types of contractors
- Types of contracts and criteria for selection
- Risks associated with the use of contractors
- Benefits of using contractors on shutdowns
- Staying in control of the contractor

### Day 5 - Shutdown and Turnaround, Execution Control and Review

- The shutdown package
- Shutdown quality control
- Shift schedules



- Preparing equipment for the shutdown
- Daily schedules
- Dealing with emergent and additional Work
- Control data
- Status accounting
- Control the Shutdown
- S-curves
- Earned-value
- Shutdown performance indicators
- Shutdown and turnaround review meeting agenda
- Why shutdowns fail
- Problems in shutdowns and their origins
- Start-up and commissioning
- Shutdown close-out reporting and review
- Shutdown closing out report
- Shutdown closing out review
- Overview of computerised tools
- Conclusion

# M14- Optimising Equipment Maintenance & Replacement Decisions

## Introduction

- Is your equipment (fixed or mobile) failing before planned replacement?
- Are you unable to execute maintenance tasks because spare parts are not available?
- Have you made significant investment in CBM methods and tools but struggle to realize the benefit?
- Do you have lots of data from oil analyses but still struggling to accurately predict your equipment breakdowns?
- Do you know how to determine optimum asset life?
- Are you struggling to justify the economics of asset replacement?
- Are you having difficulties in deciding whether to rebuild or replace your equipment to minimize the life cycle costs?
- Do you need to optimize your emergency spare requirements?

If you answer YES to any of the above questions, this seminar is for you.

## Seminar Objectives

The objectives of the program can be summarized as follows:

- To focus on the techniques of optimization – the single most important thrust of this learning program. Whether the decision is about work-crew sizes, or the replacement of component-parts or entire equipment units, the concept of making the very best, most optimal, decision will be the principal concern of the training program.
- The concept of making the very best, most optimal, decision will be the principal concern of the training program.
- To equip the participating maintenance managers, planners and schedulers and engineers with the know-how to select the most appropriate analytical tools for their maintenance decision-making.
- Reflecting the growing focus of industrial safety and the profusion of safety-related litigation – think of transportation accidents, chemical spills, and mining disasters – the program will show how safety objectives relate to the optimization models, and will underline the advantages of having a well-documented and rigorously-executed program of maintenance and replacement.
- To introduce the critical decision-making topics that can make a significant difference to the in-service time of equipment, to the costs related to doing maintenance too often or too seldom, and the optimization of asset utilization.
- To not only cover the classic need-to-know material in the area, but to acquaint the participants with leading-edge and on-the-horizon approaches that they will encounter in the near future.

## Training Methodology

The seminar will combine presentations with interactive practical exercises, supported by numerous case studies. Delegates will be encouraged to participate actively in relating the methodologies and tools presented during the 5-day seminar to the particular needs of their workplace.

## Organisational Impact

Focus on the most advanced techniques for Maintenance Optimization:

- Select the most appropriate Analytical tools for maintenance decision making
- Relate Safety objectives to optimization models
- Introduce Critical Decision-Making Topics
- Acquaint with Leading-Edge and On-The-Horizon approaches
- Continue to Apply the Seminar-Learning to your workplace problems

## Personal Impact

- Equipment maintenance and replacement decision are frequently based on informed opinions or subjective responses to common situations. In this seminar, we will deal with procedures based on careful research that is firmly rooted in reality. The seminar is intended to give you the tools needed to make data-driven decisions, which you can apply in your own environment and upon which you can rely to help you in developing appropriate programs. With so much data available, we often find ourselves in the bewildering position of being data – rich but information poor. We may have all the raw data we'll ever need at our fingertips; but unless we can interpret and integrate it properly, it is of little use. To refine this data into useful information, we need the appropriate tools.
- This seminar is designed to give you those tools. Our time is limited, and our individual interests and concerns vary. So we may not solve your particular problems in this seminar. However, I hope it will at least provide you with the concepts and techniques you need to address problems that arise as you carry out your responsibilities.

## Who Should Attend?

- Engineers
- Professionals of Plant operations
- Facility Professionals
- Maintenance or Reliability professionals who are responsible for maintaining and managing the physical equipment assets of a Plant/Facility

The ideal candidate for this seminar is an Engineer, Professional of Plant operations, Facility Professional, Maintenance or Reliability professional who is responsible for maintaining and managing the physical equipment assets of a Plant/Facility. He or she represents large Facilities and Plants from industries such as Oil and Gas, Petrochemical and Fertilizer, Pulp and Paper, Cement and Ceramics, Power Generation and Utilities, Primary Metals, and Heavy Manufacturing and Facilities.

## **Programme Outline**

### **Day 1 - Physical Asset Management & Reliability Concepts**

#### **From Maintenance Management to Physical Asset Management**

- Challenges of physical asset management
- The maintenance excellence pyramid
- Total Productive Maintenance
- Reliability Centered Maintenance
- Optimizing Maintenance & Replacement Decisions

#### **Reliability Improvement through Preventive Maintenance**

- Analysis of Component Failure Data
- Probability Density Function
- Reliability Function
- Weibull Density
- Infant Mortality
- Bath-Tub Curve

#### **Exercise in Analysing Component Failure Data Using the Weibull Distribution**

- Estimating the Weibull Parameters
- Using Median Rank Tables

#### **Dealing with Censored Data, the 3-Parameter Weibull, and the Kolomorgov-Smirnov Test**

- Upper-End Censoring, Multiply Censored Group Data
- Estimating the Location Parameter in the Weibull Distribution
- Checking the Goodness-of-Fit of the Distribution

### **Day 2 - Preventive Maintenance & Spare Parts Replacements**

#### **Reliability Improvement through Preventive Maintenance(continued)**

- Component Replacement Procedures including Glasser's Graph
- Block Replacement Policies
- Age-Based Replacement Policy
- Setting Policies based on Safety Constraints, Cost-Minimization and Availability-Maximization
- Repairable systems

#### **Case Studies in Component Preventive Replacement**

- Including boiler plant, bearings, pumps, sugar feeds, compressor valves, and centrifuges

## **Spare parts provisioning**

- Fast moving spares
- Emergency (insurance) spares

## **Case studies in spares provisioning**

- Including line replaceable units (LRUs), cylinder heads, repairable conveyor electric motors and utility transformers

## **Group and individual exercises**

### **Clinic: Hands-On Use of PC Software for Preventive Replacement Strategies**

- Participants will solve pre-set problems

## **Day 3 - Machine Health Monitoring & Inspection**

### **Reliability Improvement through Inspection**

#### **Inspection Frequency and Depth for equipment in continuous operation**

- Inspection Intervals to Maximize Profit
- Maximizing Equipment Availability
- Inspection Intervals for Equipment Used in Emergency Situations (e.g. protective devices)
- Case studies including oil and gas field equipment such as pressure safety valves (for protective devices)

#### **Health-Monitoring Procedures**

- Proportional Hazards Modelling
- Spectroscopic Oil Analysis Programs
- Optimization of Condition-Based Maintenance Procedures
- Role of software for CBM optimization
- Case studies including food processing industry (vibration monitoring), pulp and paper and shipping equipment such as compressors (vibration monitoring) and diesel engines (oil analysis), turbines in an electrical generating station (pressure measurements)

## **Day 4 - Economics of Reliability**

### **Reliability Improvement through Asset Replacement**

#### **Aspects of Discounted Cash Flow Used in Capital Equipment Replacement Analysis**

- Estimating the Interest Rate Appropriate for discounting
- Present-Value Calculations



- The effects of Inflation in the Analysis
- Calculating the Equivalent Annual Cost (EAC)

### **Economic Life of Capital Equipment**

- The “Classic” Economic Life Model
- Before-and-After Tax Calculations
- The Repair-vs-Replace Decision
- Life-Cycle Costing
- Technological Improvement

### **Group and individual exercises**

### **Clinic: Hands-On Use of PC Software for Capital Equipment Replacement Analysis**

- Participants will solve pre-set problems

## **Day 5 - Effective Management of Maintenance Resources & Information**

### **Effective Use of Maintenance Resources**

### **Organizational Structure, Crew Sizes, Workshop Resource Requirements**

- Balancing Maintenance Costs against Plant Reliability
- Establishing the optimal number of machines to have in a workshop
- Resource Requirements Using Queuing Theory and Simulation
- Utilization of Outside Resources
- Lease-vs.-Buy Decision

Case studies including balancing maintenance cost and reliability in an electrical generating station, establishing optimal mix of machines to have in a steel mill maintenance workshop, establishing shift patterns and maintenance crew sizes in a petrochemical plant.

# **M15- Economic & Technical Evaluations in Engineering & Maintenance Projects**

## **Introduction**

Engineering and maintenance projects call for complex engineering and business tradeoffs with due regard to compliance with regulatory and code requirements. A sound understanding of the key aspects of project objectives, drivers, constraints, and profitability is crucial for the success of a project. Fast-track schedules demand faster, more accurate technical and economic decisions earlier in the design process, when engineers and business managers least understands project costs. Consequently, many process facilities cost more than they should.

Using the appropriate evaluation techniques and skills, engineering and economic decisions can be reached faster, more accurately, and with greater confidence, avoiding costly project delays and potential rework.

In cases where there is competition for resources between several technically viable projects, cost and schedule factors play a key role in ranking the projects based on their profitability. Similarly, costs and schedules have a major impact on the selection of the most cost effective maintenance option from among several alternatives such as repair/replace or long/short term repairs.

The seminar covers the basics of project development and management. It begins with Project initiation and development phases and progresses through the project execution and control phase. It highlights the cost considerations and the degree of influence on costs in each phase.

Technical viability of a project, whether it involves new facilities or a repair method, must be ensured before the economic evaluation starts. The seminar presents the technical fundamentals and provides guidelines and procedures for conducting technical evaluations.

The time value of money and life cycle cost concepts are essential aspects of economic evaluations. These topics will be covered in detail with the use of a number of worked examples.

The seminar will comprise lectures and workshops that incorporate a number of short exercises to reinforce the key techniques discussed to maximize your benefits. Additionally, an optional “Question and Answer” period will provide you with opportunities to get expert answers on your specific questions.

## **Seminar Objectives**

### **To provide you with:**

- A fundamental understanding of financial and accounting principles, terms, techniques, and best practices,

- The tools you need to perform financial evaluations and justify your own project to corporate management, and
- A fundamental understanding of the technical aspects that should be considered in technical evaluations of projects to ensure their technical viability, mechanical integrity and compliance with applicable regulations, codes, and standards.

### **Training Methodology**

- The seminar combines presentations and discussions of topics covered with relevant examples.
- It combines sound engineering and economic principles, methods, and best industry practices and enforces the learning's with Case Studies and Question & Answer workshops to maximize the benefits to the participants. Participants will work in groups to perform practical technical and economic evaluations.
- Participants will be provided with comprehensive seminar notes and copies of presentation material that will be very valuable for detailed study and future reference.

### **Organisational Impact**

- The company will be able to implement fit-for-purpose projects solutions that are both technically sound and cost-effective.
- Technical and financial resources can be allocated to projects based on their ranking and cost effectiveness.
- Heightened business focus among staff will result in operational and financial performance improvements.

### **Personal Impact**

- Participants will enhance their understanding of the time value of money and life cycle cost principles.
- Participants will learn how to perform key project analyses including technical, economic, and environmental evaluations.
- Participants will add to their ability to evaluate the economic and technical impacts of alternative maintenance strategies and methods on maintenance projects and to select the optimum alternative for the specific application while complying with regulatory requirements.
- Participants will gain a working knowledge of the various cost estimating methods and how to prepare timely cost estimates that are fit for purpose.
- Participants will broaden their technical knowledge base and understand the economic impact of their technical decisions leading to increased contributions in project profitability, technical integrity and reduced downtime.
- Participants will enhance their competence and productivity thereby improving their performance level and making additional value added contributions to their organizations.

### **Who Should Attend?**

The seminar is pitched to appeal to professionals with a large range of technical and industrial backgrounds and varying levels of experience seeking to broaden their

skills and abilities in economic and technical valuation techniques required across industry.

Design, project, maintenance, and plant engineers, supervisors and professionals in the manufacturing, chemical processing, petrochemical, power, food, and other process industries. New graduates will benefit within the short period of two days from the extensive practical experience of the instructor.

## Programme Outline

### Day 1 - Project initiation and development

- Overview
  - Definitions of terms used in project development, analysis, and management
  - Project types and sizes –
    - Capital projects – Evergreen, expansions/additions, revamps
    - Maintenance projects – Shutdowns; repairs; alterations; replacements and improvements
  - Project definition, scope and drivers
    - Project mission and drivers
    - Phase 1: Concept generation – potential ways of achieving project mission
    - Phase 2: Project definition – one option is selected and developed
    - Phase 3: Project implementation – continues through construction to the hand-over of the completed project
  - Project Management Process
    - Project Planning
    - Project Scheduling
    - Feasibility study – Is the project feasible? How feasible are the alternatives under consideration; feasibility report
    - Cost, timing, performance, effect of organization
  - Key issues in project analysis
- Models of project development
  - Project evolution and life cycle
  - Basic seven phases of a project
  - Common three main phases of a project
    - Front End Loading -FEL (or Front End Definition – FEED) which includes development of the entire detailed plan and project approvals
    - Execution Phase – Detailed engineering; procurement, construction
    - Commissioning, Handover and Start-up phase
  - Project definition
    - Design Basis Document (DBD) – Development guidelines
    - Implementation strategy – owner involvement
    - Procurement policies, procedures and practices
    - Spare parts policies, procedures and practices
    - Detailed (definitive) cost estimate

- Project development
  - Project Development Plan (PDP) – Preparation Guidelines
  - Conceptual design alternatives
  - Preliminary cost estimates for alternatives
  - Responsibility charting for stakeholders
  - Selection guidelines for final design alternative
  - Preliminary feasibility analysis – technical and economic feasibility
  - Preliminary schedule
- Project execution and control
  - Project Execution Plan (PEP) – How to develop an effective execution plan
  - Coordination and Control Procedures
  - Detailed Schedule
  - Detailed Engineering
  - Safety Process Hazard Analysis
  - Construction – Logistics, work Permits, Safety
  - Quality Control / Quality Assurance
  - Project Change management System
  - Progress Monitoring and reporting
  - Project Management Tools
- Workshop 1 – Key principles and guidelines for successful projects
  - Best practices for project success
  - Common causes of project failures
  - Case study – Anatomy of a project
  - Capturing key learnings

## **Day 2 - Technical evaluation analysis**

- Project Risk and Contingency Analysis
- Key issues in project analysis
  - Market analysis – Supply and demand
  - Technical analysis – Technical viability; sensible choices
  - Financial analysis – financial viability; return on investment; risk
  - Economic analysis – social cost-benefit
  - Environmental analysis – likely ecological damage; restoration measures/costs
  - Risk analysis – Levels of risk associated with the project
- Analysis of project technical and engineering aspects
  - Purpose of technical analysis
  - Technical viability
    - Design basis
    - Existing and proven technologies
    - New and developmental technologies
    - Regulatory approvals – lead time, resources
    - Risk considerations – obsolescence, continuous technical support,
  - Sensible choices
    - Location
    - Process, equipment, methods, procedures
    - Size – optimal scale of operation

- Constructability, operability and maintainability
  - Availability of human resources, power, and other inputs
  - Realistic work schedule
- Applicable regulations, codes, standards – design and construction, HSE
- Mechanical integrity, management of change
- Environmental analysis
- Consideration on environmental aspects
  - What is the likely damage caused by the project to the environment?
  - What is the cost of restoration measures required to ensure that the damage in the environment is contained within acceptable limits?
- Applicable regulations and specifications
- Due diligence
- Project risk considerations
  - Types of Risks Associated with Projects
    - Market risk
    - Human resource
    - Financial resources
    - Technology risk
    - Management risk
    - Timing
    - Intellectual property right issues
    - Regulation risks
  - Risk assessment methods and recommended practices
  - Risk Management and Contingency
    - Level of uncertainty in project life cycle
    - Risk analysis and mitigation measures
    - Contingency
- Workshop 2 – Technical evaluation of projects
  - Case study – Technical evaluation of a capital project

### **Day 3 - Economic evaluation analysis**

- Objectives of economic evaluation analysis
  - Definitions and overview
  - Typical categories of engineering economic decisions
    - New Product and Product Expansion
    - Equipment and Process Selection
    - Equipment Replacement
    - Cost Reduction
    - Service Improvement
- Economic (financial) evaluation
  - Introduction
  - Basic concepts of economic evaluation
  - Economic evaluation methods – static and dynamic
    - Simple payback



- Benefit-cost ratio (BCR)
    - Net Present Value (NPV)
    - Internal rate of return (IRR)
  - Capital equivalent of energy and maintenance savings
- Principles of time value of money and the discount rate
  - Discounted cash flow (DCF) calculation – Definitions and premises
  - Project Cash Flow Components
  - Discounting and time-value considerations
  - Distinguishing cash flow and other measures of profitability
  - Cost of capital and inflation issues
  - Capital budgeting techniques and best practices
  - Methods of computing time-value of money
    - The algebraic (or formula) method
    - The financial table method
    - The financial calculator method
- Methods of ranking investment proposals
  - Non-Discounted Cash Flow Methods
    - Payback method (or Payback Period)
    - Accounting rate of return (ARR)
  - Discounted Cash Flow Methods
    - Net Present Value Method (NPV)
    - Internal rate of return (IRR)
  - Profitability index (PI)
- Workshop 3 – economic evaluation of projects
  - Case study – Economic evaluation of a capital project

#### **Day 4 - Business focused facilities**

- Business-focused facilities (BFF)
  - Economic interpretation of engineering work
  - Fundamental BFF principles
    - Total cost (full cycle) perspective
    - Common and clear goals
    - Adaptive process and change management
    - Teamwork
    - Continuous improvement
- Life-cycle (total) cost analysis
  - Basics of life cycle cost (LCC) analysis
  - LCC Models – SAE model
  - Life-cycle management (value management)
    - Renewal/replacement intervals,
    - Servicing costs,
    - Failure consequences,
    - Asset redundancy,
    - Maintenance strategies,
    - Energy efficiency,

- Design life service factor
- Effective life-cycle management tools
  - Engineering economics
  - Remaining life estimates
  - Statistical analysis,
  - Opportunity costing
  - LCC Calculation Procedures
- Project cost estimating
  - Types of estimates, accuracy
  - Estimating methods
  - Cost indices and economic indicators
  - Direct and indirect costs
  - Computer based estimating
- Equipment sizing and costs
  - Power Sizing Model
  - Rough estimates
  - Semi-detailed estimates
  - Detailed estimates
- Workshop 4 – cost estimating
  - Case studies – Project cost estimates using different methods

## **Day 5 - Evaluation of maintenance projects**

- Types of maintenance projects
  - Complete turnarounds – extent, frequency
  - Opportunistic minor turnarounds
  - Specialized repair methods
  - Replacement in kind and improvement opportunities
  - Specialized Inspection projects – Application and frequency
- Concept of component life
  - Introduction
  - Physical life
  - Economic life
  - Technical life – technical obsolescence
- Technical evaluation of maintenance projects
  - Key project characteristics and special requirements
    - Significance of schedule and maintainability – optimum cost or least downtime
    - Availability of human resources
    - Constructability considerations
  - Fitness-for-service assessments (FFS)
    - Basics of FFS
    - Run/repair/replace decisions
  - Alternative repair strategies and methods
    - Temporary repairs
    - Permanent repairs

- Alternate repair technologies and procedures
  - Management of change
    - Basics of management of change
    - Impact of maintenance projects on mechanical integrity and reliability
    - Regulatory, codes and standards requirements
- Workshop 5 – Evaluation of maintenance projects

## **P-Planning Courses**

P01-Projects Management Professional (PMP)

P02- Program Management Professional

P03- Certified Business Analysis Professional (CBAP)

P04- PMI Risk Management Professional

P05- PMI Scheduling Professional

P06- Primavera 6

P07- Microsoft® Project 2010

P08- Petroleum Project Economics & Risk Analysis

P09- International Oil & Gas Business Management

## P01-Projects Management Professional (PMP)

### Introduction:

PMI's Project Management Professional (PMP)® credential is the most important industry-recognized certification for project managers. Globally recognized and demanded, the PMP® demonstrates that you have the experience, education and competency to lead and direct projects.

This recognition is seen through increased marketability to employers and higher salary; according to the PMI Project Management Salary Survey–Seventh Edition, certification positively impacts project manager salaries.

### Who Should Attend?

Program managers and managers of project managers  
Project managers and other project team members  
Members of a project management office  
Customers and other stakeholders  
Functional managers with employees assigned to project teams  
Educators teaching project management and related subjects  
Consultants and other specialists in project management and related fields  
Trainers developing project management educational programs  
Researchers analyzing project management&anyone interested in the profession of project management

### Course Duration:

11 Session

### Major Topics:

**Module1- Introduction**

**Module 2- Organizational Influences and project life cycle**

**Module 3-Project Management processes**

**Module 4-Project Integration Management**

**Module 5-Project Scope Management**

**Module 6 -Project Time Management**

**Module 7 - Project Cost Management**

**Module 8- Project Quality Management**

**Module 9- Project Human Resources Management**

**Module 10-Project Communication Management**

**Module 11- Project Risk Management**

**Module 12- Project Procurement Management**

**Module 13- Project Stakeholder Management**

**Course Outlines:**

**Module1- Introduction**

- Purpose of the PMBOK® GUIDE
- What is a Project?
- What is Project Management?
- Relationships Among Portfolio, Program, project & Organizational Project Management
- Relationships between Project Management, Operations Management & Organizational strategy
- Role of Project the Manager
- Project Management Body of Knowledge

**Module 2- Organizational Influences and project life cycle**

- Organizational Influence on Project Management
- Project Stakeholders and governance
- Project Team
- Project Life cycle

**Module 3-Project Management processes**

- Common Project Management process interaction
- Project Management process group
- Initiating process group



- Planning process group
- Executing process group
- Monitoring and controlling process group
- Closing process group
- Project Information
- Role of the Knowledge area

#### **Module 4-Project Integration Management**

- Develop Project Charter
- Develop Project Management Plan
- Direct & Manage Project Execution
- Monitor &Control Project Work
- Perform Integrated Change Control
- Close Project or Phase

#### **Module 5-Project Scope Management**

- Plan Scope Management
- Collect Requirements
- Define Scope
- Create Work Breakdown Structure
- Validate Scope
- Control Scope

#### **Module 6 -Project Time Management**

- Plan Schedule Management
- Define Activities
- Sequence Activities
- Estimate Activity Resource
- Estimate Activity Duration
- Develop Schedule
- Control Schedule

#### **Module 7 - Project Cost Management**

- Plan Cost management
- Estimate Costs
- Determine Budget
- Control Costs

### **Module 8- Project Quality Management**

- Plan Quality management
- Perform quality assurance
- Perform quality control

### **Module 9- Project Human Recourses Management**

- Plan HR Management
- Acquire Project Team
- Develop project team
- Manage project team

### **Module 10-Project Communication Management**

- Plan Communications Management
- Manage Communications
- Control Communications

### **Module 11- Project Risk Management**

- Plan Risk Management
- Identify Risks
- Perform Qualitative Risk Analysis
- Perform Quantitative Risk Analysis
- Plan Risk Responses
- Monitor and Control Risks in chapter 11

### **Module 12- Project Procurement Management**

- Plan Procurement Management
- Conduct Procurements
- Control Procurements
- Close Procurements

## **Module 13- Project Stakeholder Management**

- Identify Stakeholders
- Plan Stakeholder Management
- Manage Stakeholder Engagement
- Engaged Stakeholder Engagement

## **P02-Program Management Professional**

### **Introduction:**

PMI's Program Management Professional (PgMP)® credential recognizes the advanced experience and skill of program managers. Globally recognized and demanded, the PgMP® demonstrates your proven competency to oversee multiple, related projects and their resources to achieve strategic business goals.

PgMP credential holders oversee the success of a program, grouping related projects together to realize organizational benefits not available if they were managed separately. It's the perfect fit if you define projects, assign project managers and oversee programs.

### **Who Should Attend?**

If you're a program manager looking to demonstrate a proven ability to manage complex, multiple projects and align results to organizational goals; increase your visibility and value with your organization; and separate yourself in the eyes of employers, the PgMP credential is for you.

### **Course Duration:**

5 Session

### **Course Outlines:**

#### **Program Management Foundations**

- \* Role of the PMO & the program manager
- \* Program life-cycle
- \* Program management processes & process groups
- \* Program management knowledge areas
- \* Applying the life-cycle to each of the knowledge areas

#### **1- Strategic Program Management Domain**

- \* Program governance procedures
- \* Program selection & creating a business case
- \* Initial program planning
- \* Working with stakeholders
- \* Preliminary financial planning

## **2- Program Life Cycle Domain**

### **2-A- Initiating Program**

- \* Establishing governance
- \* Determining the financial framework
- \* Creating the core team
- \* Identifying & working with program stakeholders
- \* Linking benefits to current plans

### **2-B- Planning Program**

- \* Planning & the life-cycle phases involved
- \* Planning for all of the main areas; benefits, stakeholders, program scope & work scope, communications, scheduling, financial management, resources & program infrastructure, quality, risk, procurement
- \* Creating the program management plan with considerations on transitioning the outcomes
- \* Executing Program
- \* Ensuring the plan is executed
- \* Delivering the benefits
- \* Ensuring effective procurement
- \* Dealing with audits
- \* Distributing information
- \* Working with stakeholders

### **2-C- Controlling Program**

- \* Monitoring & controlling progress
- \* Controlling scope and schedule
- \* Financial & cost control
- \* Benefits management
- \* Controlling resources , issues and risks

### **2- D Closing Program**

- \* Stakeholder communications
- \* Lessons learned
- \* Closing all outstanding contracts
- \* Transition & ensuring benefits sustainment
- \* Certification exam-style questions

## **3- Benefit Management**

## **4- Stakeholder Management**

## **5- Governance**



## **P03- Certified Business Analysis Professional (CBAP)**

### **Introduction:**

The International Institute of Business Analysis (IIBA®) has created the Certified Business Analysis Professional™ (CBAP®), a designation awarded to candidates who have successfully demonstrated their expertise in this field. This is done by detailing hands-on work experience in business analysis through the CBAP® application process, and passing the IIBA® CBAP® examination.

Certified Business Analysis Professionals are experts in identifying the business needs of an organization in order to determine the best solutions, a role that is increasingly seen as a vital component of any successful project.

International Institute of Business Analysis (IIBA) is the independent non-profit professional association for the growing field of business analysis. The goal of IIBA is to create greater awareness of the Business Analysis (BA) profession by defining what is business analysis and working towards recognition of the value of the business analyst role in the organization. BA can help the organization to gain a competitive advantage in the marketplace and enable the organization to succeed. Business Analysis is the practice of enabling change in an organizational context, by defining needs and recommending solutions that deliver value to stakeholders. The set of tasks and techniques that are used to perform business analysis are defined in A Guide to the Business Analysis Body of Knowledge (BABOK®Guide).

Business analysis involves:

- Understanding why the organization exist
- Understanding how organizations function to accomplish their purposes
- Defining the capabilities an organization requires to provide products and services to external stakeholders.
- Determining the courses of action that an organization has to undertake to achieve those goals and objectives

This course will go over best practices in business analysis and prepare Participants to take the Certified Business Analysis Professional (CBAP) exam.

## **Business Analysis Body of Knowledge (BABOK®Guide)**

The BABOK Guide describes business analysis knowledge areas, their associated activities and tasks, and the skills necessary to be effective in their execution. The primary purpose of the BABOK Guide is to define the profession of business analysis. It serves as a baseline that practitioners can agree upon in order to discuss the work they do and to ensure that they have the skills they need to effectively perform the role, and defines the skills and knowledge that people who work with and employ business analysts should expect a skilled practitioner to demonstrate.

### **Who Should Attend?**

Any person who performs business analysis activities, no matter what their job title or organizational role may be. Business analysis practitioners also include business systems analysts, systems analysts, requirements engineers, process analysts, product managers, product owners, enterprise analysts, business architects, management consultants, and those who also perform related disciplines such as project management, software development, quality assurance, and interaction design.

### **In What Industries?**

Government, Real Estate Development, Aerospace, Defense, Engineering and Construction, Manufacturing and Industrial, Oil and Gas, Petrochemical, Power and Water Utility Plants, Education and Training, Retail, Financial Services, Information Technology, Telecommunication, Automotive, Media Production, E-Business, Marketing and Sales, Pharmaceuticals, Environmental Management, Hospitality Management, Shipbuilding and Repair Yards.

### **Course Duration:**

8 Session

## Course Outlines:

Session 1:

- a. Foundation concepts
- b. Elicitation

Session 2:

Business Analysis Planning and Monitoring

Session 3:

Enterprise analysis

Session 4:

Requirement management and Communication

Session 5:

Requirement Analysis

Session 6:

Solution Assessment and validation

Session 7:

- a. Underlying Concepts
- b. BA Techniques Part 1

Session 8:

- a. BA Techniques Part 2
- b. Simulation test

## **P04- PMI Risk Management Professional**

### **Introduction:**

Some organizations manage risk better than others. Project after project results show that risk management is crucial for successful outcomes. How do organizations accomplish this? What are the best practices in risk management that are needed to be successful in today's changing environment. This presentation will discuss the risk management process and identify how organizations are putting this into practice to maximize project success. Based on their work with global clients and formal research, We will outline the lessons learned, and tools used, in risk Planning, identification, qualification, quantification, mitigation and control. In addition, We will provide tactical recommendations on how to put these concepts into practice back on the job.

### **Who Should Attend?**

This course is targeted all Certified PMPs , Chief Executive Officers, Finance Managers, Human Resources Managers, Project Managers, Engineers and Planners, Information Technology Managers.

### **Course Duration:**

8 Session

### **Course Outlines:**

- **Risk Strategy and Planning**
  - \* Develop risk assessment processes and tools that quantify stakeholder risk tolerances in order to assess and determine risk thresholds for the project and set criteria for risk levels.
  - \* Update risk policies and procedures using information such as lessons learned from projects and outputs of risk audits in order to improve risk management effectiveness
  - \* Develop and recommend project risk strategy based on project objectives in order to establish the outline for the risk management plan.
  - \* Produce risk management plan for the project on the basis of inputs such as project information, external factors, stakeholder inputs, and industry policies and procedures in order to define, fund,

and staff effective risk management processes for the project that align with other project plans.

- \* Establish evaluation criteria for risk management processes based on project baselines and objectives in order to measure effectiveness of the project risk process.

- **Stakeholder Engagement**

- \* Promote a common understanding of the value of risk management by using interpersonal skills in order to foster an appropriate level of shared accountability, responsibility, and risk ownership.

- \* Train, coach, and educate stakeholders in risk principles and processes in order to create shared understanding of principles and processes, and foster engagement in risk management

- \* Coach project team members in implementing risk processes in order to ensure the consistent application of risk processes.

- \* Assess stakeholder risk tolerance using processes and tools such as interviewing stakeholders and reviewing historical stakeholder behaviors in order to identify project risk thresholds.

- \* Identify stakeholder risk attitudes and cognitive biases using stakeholder analysis techniques in order to manage stakeholder expectations and responses throughout the life of the project.

- \* Engage stakeholders on risk prioritization process based on stakeholder risk tolerance and other relevant criteria, in order to optimize consensus regarding priorities

- \* Provide risk-related recommendations to stakeholders regarding risk strategy and planning, risk process facilitation, risk reporting, and specialized risk tasks by using effective communication techniques in order to support effective risk-based decision making.

- \* Promote risk ownership by proactively communicating roles and responsibilities and engaging project team members in the development of risk responses in order to improve risk response execution.

- \* Liaise with stakeholders of other projects by using effective communication techniques and sharing information on project risk

performance in order to inform them of implications for their projects.

- **Risk Process Facilitation**

- \* Apply risk assessment processes and tools in order to quantify stakeholder risk tolerances and determine risk levels.

- \* Facilitate risk identification using a variety of techniques in order to enable the project team and stakeholders to understand and determine the risk exposure of the project.

- \* Facilitate the project team's evaluation of the identified risks' attributes using qualitative and quantitative tools and techniques in order to prioritize the risks for response planning.

- \* Facilitate the development of an aligned risk response strategy and related risk actions by risk owners from the information gathered during risk analysis in order to ensure timely and defined action when required.

- \* Facilitate the formulation of project contingency reserve based on the risk exposure of the project in order to have the capability and resources to respond to realized risks.

- \* Provide risk data to cost and schedule analysts/estimators to ensure that project risk is properly reflected in cost and schedule estimates for the project.

- \* Use scenarios to validate potential risk responses and evaluate key dependencies and requirements in order to enhance the likelihood of project success.

- **Risk Monitoring and Reporting**

- \* Document and periodically update project risk information using standard tools (including but not limited to risk register, risk database) and techniques in order to maintain a single, current repository of all project risk information.

- \* Coordinate with project manager using communication techniques in order to integrate risk management throughout the project.

- \* Create periodic standard and custom reports using risk-related metrics as specified in the risk management plan in order to communicate risk management activities and status.

- \* Monitor risk response metrics by analyzing risk response performance information, and present to key stakeholders in order to ensure resolution of risk and develop additional risk response strategies to address residual and secondary risks.

- \* Analyze risk process performance against established metrics in order to drive risk process improvements.

- \* Update the project risk management plan using relevant internal and external inputs in order to keep the plan current.

- \* Capture risk lessons learned through comprehensive review of the project risk management plan, risk register, risk audits, risk process performance reports, and other associated reports in order to incorporate into future risk planning.

- **Perform Specialized Risk Analyses**

- \* Evaluate the attributes of identified risks using advanced quantitative tools and specialized qualitative techniques in order to estimate overall risk exposure of the project.

- \* Analyze risk data produced during the project using statistical analyses and expert judgment in order to determine strengths and weaknesses of risk strategy and processes and recommend process improvements when indicated.

- \* Perform specialized risk analysis using advanced tools and techniques in order to support stakeholder decision making for the project.



## **P05- PMI Scheduling Professional**

### **Introduction:**

PMI's Scheduling Professional (PMI-SP)® credential is a response to project management's increasing growth, complexity and diversity. Globally recognized and demanded, the PMI-SP® fills the need for a specialist role in project scheduling.

It recognizes your unique expertise and competence to develop and maintain project schedules, while still possessing baseline knowledge skills in all areas of project management.

At the end of this course, participants will gain the following:

This six days training course will provide participants with a through background in the concepts of Planning and Scheduling Engineering and Construction projects. The course addresses how to identify, monitor, and balance information crucial for the successful management of projects. It will discuss the development of a baseline performance management plan (PMP) for the project that will allow the efficient compilation and the timely generation of quantitative performance comparisons. The comparisons highlight significant performance departures ("actual vs. baseline") and allow for preventive and early remedial and corrective actions.

### **Who Should Attend?**

The PMI-SP demonstrates skill and competence in the specialized area of project scheduling. If you're looking to fill the scheduling specialist role on your project team, hone your basic project management skills and showcase your specialized expertise to employers, the PMI-SP credential is for you.

### **Course Duration:**

6 Session

## Course Outlines:

### • **Unit 1: Project Management Framework**

- Identify Project Management Basics
- Examine Organizational Influences on Project Management
- Examine the Project Management Context Identifying Project Management Processes
- Examine the Project Life Cycle
- Recognize Process Groups

### • **Unit 2: Enterprise Project Structure (EPS) and Organizational Breakdown Structure (OBS)**

- Describe Project Selection Methods and Processes
- Create a Project SOW
- Create a Project Charter
- Describe the Elements of a Project Management Plan
- Create a Scope Statement
- Identify Enterprise Environmental Factors

### • **Unit 3: WBS and Activity Identification**

- Explore WBS Creation
- Explore Activity Definition
- Create a Milestone List
- Create an Activity List
- Identify Activity Attributes

### • **Unit 4: Develop Network Diagram**

- Describe the Process of sequencing Project Activities
- Determine Activity Dependencies and Relationships
- Apply Lag and Lead in Activity Sequence
- Create a Schedule Network Diagram

- **Unit 5: Estimating Activity Resources & Durations**

- Identify Activity Resources
- Determine Activity Resource Requirements
- Describe the Process of Developing a Project Schedule
- Draft a Project Schedule

- **Unit 6: Network Schedule Calculation**

- Identify the Critical Path
- Optimize the Project Schedule
- Establish a Schedule Baseline
- Create Schedule Data

- **Unit 7: Earned Value Management**

- Explore the Control Schedule Process by EV
- Utilize an Integrated Change Control System
- Monitor the Schedule
- Calculate Schedule Efficiency

- **Unit 8: Project Report**

- Communicate the Project Status

## P06- Primavera 6

### Introduction:

The objective of this training course is to introduce the participants to Primavera 6® software for successful project management.

### Who Should Attend?

Program Managers, Project Managers, and Planners/Schedulers who are or will be involved in the areas of engineering, production, construction, information technology.

Primavera 6® will give them very strong and successful tool for planning and managing their projects.

### Course Duration:

5 Session

### Course Outlines:

#### **Day 1**

Introduction to Primavera

Project Management life cycle

Network planning

- Critical path method (CPM)
- Schedule calculations

Navigation

Setting up the Enterprise Project Structure (EPS)

Setting up the Organizational breakdown Structure (OBS)

Creating a new Project

Work breakdown structure (WBS)

- Creating WBS Hierarchy
- Adding WBS Elements and Assigning Properties

Working with Activities

- Activity Types
- Adding Activities
- Establishing Relationships

- Project Scheduling

## **Day 2**

- Constraints Types
- Working with Calendars
- Working with Calendars (Global, Project)
- Create new project Calendars
- Establishing Activity Codes
- Creating Activity Codes and Values
- Assigning Codes to activities
- Maintaining a Project's Document Library
- Adding/Deleting Work Products And Documents
- Assigning Work Products and Documents To Activities
- Working with Layouts
- Creating, Opening, and Saving Layouts

## **Day3**

Grouping, Sorting Data

Filtering Data

Customizing Layouts

- Modifying Columns, Adjusting the Timescale, Formatting Gantt Charts

Produce bar chart reports

Produce schedule reports

Defining Resources and Roles

- Resources Overview
- Viewing and Adding Resources

Working with Cost Accounts and Project Expenses

- Setting Up a Cost Account Structure
- Adding Expenses and Entering Cost Information

Analyzing Resources and Costs

Producing Resource Usage Profile

Producing Resource Usage spreadsheet

Updating process

## **Day 4**

Managing Baselines

Creating and Maintaining Baselines  
Assigning Baselines to Projects  
Updating  
Choosing a Method of Updating  
Record project progress  
Scheduling Projects  
Current vs. Baseline comparison report

**Workshops:**

Creating a Project  
Creating a Work Breakdown Structure (WBS)  
Adding Activities  
Scheduling the Project  
Working with Calendars  
Activity Codes  
Producing Bar Chart Report  
Assigning Resource and Cost  
Analyzing Resource and Cost  
Updating the Schedule

## P07- Microsoft® Project 2010

### Introduction:

The objective of this training course is to introduce the participants to Microsoft Project 2010 software for successful project management.

### Who Should Attend?

Program Managers, Project Managers, and Planners/Schedulers who are or will be involved in the areas of engineering, production, construction, information technology.

Microsoft Project 2010 will give them very strong and successful tool for planning and managing their projects.

### Course Duration:

5 Session

### Course Outlines:

#### **Lesson 1: Getting Started with Microsoft Project**

**Topic 1A:** Explore the Microsoft Project 2010 Environment

**Topic 1B:** Display an Existing Project Plan in Different Views

#### **Lesson 2: Creating a Project Plan**

**Topic 2A:** Create a Project Plan

**Topic 2B:** Assign a Project Calendar

**Topic 2C:** Add Tasks to a Project Plan

**Topic 2D:** Enter the Task Duration Estimates

**Topic 2E:** Add Resources to a Project Plan

#### **Lesson 3: Managing Tasks in a Project Plan**

**Topic 3A:** Outline Tasks

**Topic 3B:** Link Dependent Tasks

**Topic 3C:** Set Task Constraints and Deadlines

**Topic 3D:** Add Notes to a Task



**Topic 3E:** Add a Recurring Task

**Lesson 4: Managing Resources in a Project Plan**

**Topic 4A:** Create a Resource Calendar

**Topic 4B:** Assign Resources to Tasks

**Topic 4C:** Enter Costs for Resources

**Topic 4D:** Resolve Resource Conflicts

**Lesson 5: Finalizing a Project Plan**

**Topic 5A:** Shorten a Project Using the Critical Path

**Topic 5B:** Set a Baseline

**Topic 5C:** Print a Project Summary Report

## **P08- Petroleum Project Economics & Risk Analysis**

### **Introduction:**

This program provides practical guidance in the application of the techniques of the economic analysis currently used in the oil & gas industry. When executing a petroleum related project, such as a field development, you should be able to choose the best alternative from economic point of view. You should be able to properly evaluate various investment opportunities by determining economic indicators and sensitivity analysis. Techniques for predicting profit, production, costs, and cash flow enable the analyst to evaluate decision alternatives for optimum results. Understanding economic indicators, risk and uncertainty.

### **Who Should Attend?**

Oil & gas professionals such as engineers, geologists, economists, accountants, technicians who need to learn how to conduct economic evaluation and to understand the role of petroleum economics in investment decision making. This program is also recommended for supervisors & managers in the Planning, Exploration, Production, Projects, Financing and Technical Departments in Oil & Gas Companies.

### **Course Duration:**

5 Session

### **Course Outlines:**

#### **Day 1 - Cash Flow Analysis**

- Familiarization with Economic terms
- Feasibility Studies
- Setting up Cash Flow Calculation
- Depreciation
- Depreciation Methods
- Loss Carry Forwards
- Inflation
- Nominal & Real Cash Flow
- Sunk Costs
- Project Financing

## **Day 2 - Economic Indicators**

- Economic Indicators Definitions
- Present Value Concept
- Discount Factor
- Net Present Value
- Internal Rate of Return
- Effect of Project Delay
- Payback Period
- Profit/Investment Ratio
- Incremental Projects
- Comparing Economic Indicators

## **Day 3 - Risks and Uncertainties**

- Risk & Uncertainty
- Expected Value Concept
- Decision Tree Analysis
- Farm-out Decision
- Probability Analysis
- Sensitivity Analysis
- Spider and Tornado Diagrams
- Probability Distribution
- Monte Carlo Simulation

## **Day 4 - Setting up Spreadsheet Calculation**

- Introduction to Spreadsheet Calculation
- Simple Cash Flow Using Excel

## **Day 5 - Setting up Oil Field Development Model**

- Setting up an Integrated Economic Model of a Typical Oil Field Development Project including Sensitivity Analysis

## **P09- International Oil & Gas Business Management**

### **Introduction:**

Oil and gas are considered among the world's most important resources. The oil and gas industry plays a critical role in driving the global economy. Petroleum itself is used for numerous products, in addition to serving as the world's primary fuel source.

The processes and systems involved in producing and distributing oil and gas are highly complex, capital-intensive and require state-of-the-art technology.

Crude oil is almost never used as produced. It is refined to make "white" products—liquefied petroleum gas (cooking gas), gasoline, kerosene, and diesel—and residual fuel oil. Worldwide, demand for white products is growing much more rapidly than that for residual fuel oil (used to generate electricity or heat).

As the oil industry faces challenges related to climate change, alternative energies, energy substitutions and adverse changes in the quality of available downstream feedstocks, it recognizes the need for managers who have a comprehensive and broad understanding of the industry, including economics, evaluation and decision-making skills and who understand the issues that face the oil and gas industries in the future.

This course will provide a basis for functional managers and those whose experience has been limited to a particular area of the industry, to prepare for additional responsibilities by providing a broad base of knowledge covering the total spectrum of the oil and gas business and specific skills related to the evaluation of opportunities and enhanced decision-making.

### **Who Should Attend?**

- Engineers
- Managers
- Professionals
- Employees working in the areas of Planning, Marketing or Finance
- Anyone requiring a broad understanding of the structure, operations and economics of the oil and gas industries

### **Course Duration:**

5 Session

## Course Outlines:

### **Day 1 - Sources, Origin and Nature of Petroleum**

- Fundamentals of organic chemistry
  - Definition of Petroleum
  - The oil and gas Industry
- Basic petroleum geology
  - Origins of Hydrocarbon Deposits
- Exploration activities
  - Exploration Methods
  - Drilling Proposal
  - Types of Well

### **Day 2 - Sources, Origin and Nature of Petroleum**

- Oil and gas field development
- Production
- Well fluids and surface production operations
- Transportation

### **Day 3 - Oil Companies, Corporate Relationships and Structures**

- Operating companies and service companies
- Local, national and multi-national oil and gas companies
  - Major International Oil Companies
  - National Oil and Gas Companies
- Integrated and non-integrated companies
  - Intergrated Companies
  - Non-intergrated Companies

### **Day 4 - Oil Companies, Corporate Relationships and Structures**

- Organization of Petroleum Exporting Companies (OPEC)
- Other international and multi-national organizations
  - International Energy Agency (IEA)
- Production sharing agreements

### **Day 5 - Processing Operations and Economics**

- Oil refining operations
  - Distillation
  - Product improvement processes
  - Product conversion processes
  - Other operations

### **Day 6 - Processing Operations and Economics**

- Gas processing operations
  - Inlet separation
  - Sulfur removal and sulfur recovery
  - Dehydration
  - Dewpoint control and byproduct recovery
  - Gas compression
  - Basic economics of the oil and gas industries

### **Day 7 - Evaluation of Oil and Gas Opportunities**

- Estimating the cost of oil and gas facilities
- Using historical costs
  - Cost curves
  - Adjusting for different sizes
  - Adjusting for different time periods

### **Day 8 - Evaluation of Oil and Gas Opportunities**

- Building cashflow models
  - What is financial modeling?
  - Who does Financial Modeling?
  - What are the steps in building a financial model?
- Using cashflow models to evaluate projects
  - Internal rate of return
  - Net present value
  - Benchmark indicators

### **Day 9 - Making Decisions under Conditions of Certainty and Uncertainty**

- Certainty
  - Risk
  - Crisis problem
- Uncertainty
- The role of probability in decisions
- Mathematical modeling of business processes

## **Day 10 - Making Decisions under Conditions of Certainty and Uncertainty**

- Making management decisions under conditions of certainty
- Optimization of the model and interpretation of results
- Making management decisions under conditions of uncertain



## **I-Instrument & Control Courses**

- I01** -Pneumatic, Electro-Pneumatic& Hydraulic Systems, Design, Operation &Maintenance.
- I02** -Industrial Process Measurement
- I03** -Flow Meters Calibration and Troubleshooting
- I04** -Crude& Gas Metering System.
- I05** -Level Measurement and Automatic Tank Gauging
- I06** -Analytical Instrumentation in On-Line Applications
- I07** -Advanced Process Control
- I08** -Integrated Control Systems
- I09** -Practical Alarm Management System
- I10** -Safety Instrumentation and Emergency Shutdown System
- I11** -Distributed Control Systems ‘DCS’ operation maintenance and troubleshooting
- I12** -Programmable Logic Controllers (PLCs)
- I13** -SCADA Systems for Process control
- I14** -Boiler Control and Instrumentation for Engineers and Technicians
- I15** -Functional Specifications for PLCs, DCSs and SCADA systems
- I16** -Instrumentation Installation in Hazardous Areas and Equipment Selection
- I17** -Tuning of Industrial Control Loops
- I18** -Practical Fundamentals of OPC
- I19** -Control Valve Sizing, Selection and Maintenance

**I20-Safety Relief Valves: Inspection, Operation and Troubleshooting**

**I21-Fire and Gas Detection systems**

**I22-Field Bus System: Architecture, Configuration and Applications**

**I23-Industrial Data Communication System**

**I24-Applying Standard Instrumentation and Control Documentation**

**I25-Selection, Calibration, Maintenance and Troubleshooting for Field Devices and Control Systems**

**I26-Practical Hazop, trips and alarms**

**I27-Preparation for Functional Safety Certification “FS Engineer”**

### **E-Electrical Courses**

E01-Electrical Maintenance

E02-Electrical Motors

E03-Electrical Power Transformer

E04-Electrical Generators

E05-Batteries, Battery Chargers and UPS systems

E06-Electrical protection systems

E07-Electrical Control Devices

E08-Switchgears and Motor control Centers

E09-Electrical Installation in Hazardous area

E10-Electrical Cables Selection, Sizing, Rout, Sections & Inspection

E11-Electrical Lighting System in Hazardous areas

E12-Electrical High Voltage Techniques

E13-Electrical Protection Systems of electrical assets

E14- Generator Excitation Systems & AVR Selection, Commissioning, Operation, Maintenance, Testing & Troubleshooting

E15-Electrical Equipment & Systems (Installation, Troubleshooting & Maintenance)

E16-Electrical safety

E17-Grounding in Electrical Systems & Noise Reduction in Instrument Loops

E18-Variable Speed Drives Protecting & Increasing the Performance

E19-Uninterruptible Power Supply (UPS) Installation, Operation & Troubleshooting

E20-Power factor correction and Harmonics Filtering

E21-Batteries Running, Safety & Maintenance of Battery Systems

E22-Power Quality Problems & Troubleshooting

E23-Lightning & Surge Protection

E24-Reading Electrical Drawings & Schematics

E25-Electrical Engineering Basics (Technical Manager)

E26-Electrical Engineering Fundamental

E27-Electrical Power System for Electrical Technician

# **I01-Pneumatic, Electro-Pneumatic& Hydraulic Systems, Design, Operation & Maintenance**

## **Introduction:**

This course is designed to increase the knowledge and practical skills of mechanical or electrical technicians enabling them to work safely on hydraulic equipment and the associated controls.

## **Who Should Attend?**

Mechanical, Electrical & Instrument Engineers and technician .

## **Course Duration:**

5 Days

## **Major Topics:**

Module 1 – Pneumatic Circuits basics

Module 2 – Electro pneumatic Circuits basics

Module 3 – Hydraulic Circuits basics

Module 4 – Design, Operation& Maintenance

## **Course Outlines:**

### **Module 1 – Pneumatic Circuits basics**

- Safety precautions related to compressed air
- Components in pneumatic systems
- Pneumatic symbols and circuit diagrams
- Filter, regulator and lubricator units
- Pneumatic cylinders
- Pneumatic control and shut off valves

### **Module 2 – Electro pneumatic Circuits basics**

- Components in Electro pneumatic systems

- Electro Pneumatic symbols and circuit diagrams
- Conversion from Electro Pneumatic to pneumatic systems

### **Module 3 – Hydraulic Circuits basics**

- Health and Safety related to hydraulics
- Basic principles and recognition of hydraulic symbols
- Identification of hydraulic components
- Pressure formulae for hydraulic cylinders
- Pumps and power packs
- Hydraulic valves, cylinders and motors
- Hydraulic circuit building exercises
- Fault finding on hydraulic circuits

### **Module 4 – Design, Operation& Maintenance**

- Maintenance of systems
- Interlocking and automated circuits
- Practical circuit building exercises
- Methods of tracing and rectifying faults
- Installation and troubleshooting techniques

## **I02-Industrial Process Measurement**

### **Introduction:**

This course is designed to increase the knowledge and practical skills of instrument engineers and technician about industrial process measurement.

### **Who Should Attend?**

Instrument or process control engineers and technicians .

### **Course Duration:**

5 Days

### **Major Topics:**

Module 1 – Measurement Fundamentals

Module 2 – Pressure Measurement

Module 3 – Temperature Measurement

Module 4–Level Measurement

Module 5– Flow Measurement

### **Course Outlines:**

#### **Module 1 – Measurement Fundamentals**

- Measurement terminologies
- The types of transmitters, indicators and switches

#### **Module 2 – Pressure Measurement**

- Units and terminology
- The pressure elements
- Manometers
- Mechanical Pressure Transducers
- Electrical Pressure Elements Principles
- Electronic Pressure Elements - Strain Gage and Crystals

- Installation Considerations - Instrumentation Protection and Design Factors for Accuracy
- Hookup and wiring Drawings for pressure and differential pressure
- Elements limitations and installation requirements.
- Selection of the sensor for different applications.

### **Module 3 – Temperature Measurement**

- List units and terminology
- Temperature elements (RTD / TC)
- Hookup and wiring Drawings
- Elements limitations and installation requirements.
- Selection of the sensor for different applications.
- Factors affecting measurement accuracy
- Classification of Thermometers
- Electric Temperature Measuring Device

### **Module 4- Level Measurement**

- Units and terminology
- Introduction to Level Measurement - Basic Concepts and Selecting Measurement Devices
- Visual Level Sensor
- Variable Displacement Devices
- Head Pressure Measurement Sensors
- Electrical Level Sensors - Capacitance, Conductivity, and Resistance
- Ultrasonic Sensors - Sound Waves, Point and Continuous Measurement, and Non-Invasive Ultrasonic Sensors
- Other Level Measuring Devices - Rotating and Vibrating Paddles, Thermal Sensing, Nuclear Devices and gravimetric Level Measurement
- Hookup and wiring Drawings
- Elements limitations and installation requirements.
- Selection of the sensor for different applications.

### **Module 5- Flow Measurement**

- Units and terminology



- Principles Affecting Flow - Flow Rate, Density, and Viscosity
- Measuring with Differential Pressure - Physical Principles and Measuring Devices
- The “Orifice” Flow meter
- The “Vortex” Flow meter
- The “Turbine” Flow meter
- The “UltraSonic” Flow meter
- The “Magnetic” Flow meter
- The “Mass” Flow Meter

## **I03-Flow Meters Calibration and Troubleshooting**

### **Introduction:**

This course is designed to increase the knowledge and practical skills of instrument engineers and technician about Flow Meters Calibration and Troubleshooting.

### **Who Should Attend?**

Instrument or process control engineers and technicians .

### **Course Duration:**

5 Days

### **Major Topics:**

Module 1 – Basic Properties of Fluids

Module 2 – Positive Displacement Meters

Module 3 – Inferential Meters

Module 4 – Oscillatory Flow Meters

Module 5 – Differential Pressure Meters

Module 6 – Variable Area Meters

Module 7 – Electromagnetic Flow Meters

Module 8 – Ultrasonic Flow Meters

Module 9 – Mass Flow Measurement

Module 10 – Open Channel Flow Measurement

### **Course Outlines:**

**Module 1 – Basic Properties of Fluids**

- Basic fluid properties
- Non-Newtonian fluids
- Velocity profiles
- Reynolds number
- Flow measurement
- Mass flow rate
- Multi-phase flows

### **Module 2 – Positive Displacement Meters**

- Sliding vane
- Oval gear meters
- Lobed impeller
- Oscillating piston
- Nutating disc

### **Module 3 – Inferential Meters**

- Turbine meter
- Woltman meter
- Propeller type
- Impeller meters
- Installation recommendations

### **Module 4 – Oscillatory Flow Meters**

- Primary devices
- Sensors

- Application guidelines for vortex flow metering
- Avoiding problems of this type

### **Module 5 – Differential Pressure Meters**

- Basic theory
- Orifice plate
- Tapping points
- Venturi tube meter
- Venturi and flow nozzles
- The Dall tube
- Target meter
- Pitot tube
- Point averaging
- Elbow
- Troubleshooting

### **Module 6 – Variable Area Meters**

- Operating principle
- Floats
- Metering tube

### **Module 7 – Electromagnetic Flow Meters**

- Measuring principle
- Construction
- Conductivity

- Field characterization
- Measurement in partially filled pipes
- Empty pipe detection
- Field excitation
- The pulsed D.C. field
- Bipolar pulse operation
- Meter sizing

### **Module 8 – Ultrasonic Flow Meters**

- Doppler method
- Transit time meter
- Flow profile
- Frequency difference
- Clamp on instruments
- Velocity of sound measurement
- Factors influencing the velocity of sound
- Beam scattering
- Summary
- Advantages
- Disadvantages
- Application limitations

### **Module 9 – Mass Flow Measurement**

- The Coriolis force
- Multiple phase flow
- Density measurement

- Loop arrangements
- Straight through tube
- Application in the food industry
- Applications in the chemical industry
- Summary of Coriolis mass measurement
- Thermal mass meters

### **Module 10 – Open Channel Flow Measurement**

- The Weir
- The flume
- Level measurement
- Linearization

## **I04-Crude & Gas Metering System**

### **Introduction:**

The metering systems are provided to enhance the accurate measurements of crude oil and prevent losses due to measurement variances/errors. Knowing these meters and the calibration procedures together with the techniques used in measurement are very important to study.

### **Who Should Attend?**

Instrument or process control engineers and technicians .

### **Course Duration:**

5 Days

### **Major Topics:**

Module 1 –Fiscal Metering

Module 2 – Field Instruments

Module 3 – Operating Procedures

Module 4 – Installation, Maintenance and repair

### **Course Outlines:**

#### **Module 1 – Fiscal Metering**

- Introduction
- Concepts and practice of custody transfer metering
- Fundamentals of fiscal metering
- Commercial implications of fiscal metering

#### **Module 2 – Field Instruments**

- Theory of functionality of field instruments
- Processing of data received from field instruments
- Calculation methods used for fiscal quantities
- Metering algorithms



- Processing of fiscal data
- Calibration
- Application of standards and re-certification of systems and instruments

### **Module 3 – Operating Procedures**

- Fiscal metering in practice
- Startup
- Shutdown
- Operating conditions
- Fault conditions
- Limitations

### **Module 4 – Installation, Maintenance and repair**

- Installation
- Commissioning
- Maintenance
- Fault diagnostics and troubleshooting

## **I05-Level Measurement and Automatic Tank Gauging**

### **Introduction:**

This course will focus on the knowledge of level measurement and automatic tank gauging.

### **Who Should Attend?**

Instrument or process control engineers and technicians .

### **Course Duration:**

5 Days

### **Major Topics:**

Module 1 – Level Sensor Selection

Module 2 – Pressure/ Density Level Instrumentation

Module 3 –RF/Capacitance Level Instrumentation

Module 4 – Level Switches

Module 5 – Automatic Tank Gauging

### **Course Outlines:**

#### **Module 1 – Level Sensor Selection**

- Level sensor selection criteria
- Existing technologies in level measurement

#### **Module 2 – Pressure/ Density Level Instrumentation**

- Dry and Wet leg designs
- Bubbler tubes
- Float and displacers
- Differential pressure level transmitters
- Interface application

### **Module 3 – RF/Capacitance Level Instrumentation**

- Capacitance Level Instrumentation
- Radar and Microwave level transmitters
- Nuclear Level Sensor
- Installation and application consideration

### **Module 4 – Level Switches**

- Thermal Switches
- Vibrating Switches
- Optical Switches
- Avoiding problems of this type

### **Module 5 – Automatic Tank Gauging**

- What is Tank Gauging?
- General requirements for a Tank Gauging System
- Principle of Measurement

## **I06-Analytical Instrumentation in On-Line Applications**

### **Introduction:**

On-line analytical measurement has become an integral part of process control measurement. As a result, a working knowledge of analytical measurement is now a prerequisite for anyone working with process instrumentation and control.

### **Who Should Attend?**

Instrument or process control engineers and technicians .

### **Course Duration:**

5 Days

### **Major Topics:**

Module 1 – Electrochemical Cell

Module 2 – pH measurement

Module 3 – Conductivity measurement

Module 4– Dissolved Oxygen measurement

Module 5–Gas Chromatography

### **Course Outlines:**

#### **Module 1 – Electrochemical Cell**

- Electrode potentials
- Simple voltaic cell
- Polarization
- Daniell cell
- Electrolytic bridges
- Electrochemical series

#### **Module 2 – pH measurement**

- Definition of pH
- Measurement of pH
- The measuring electrode
- The reference electrode
- Nernst equation
- Temperature effect
- Antimony electrode
- Sources of errors

### **Module 3 – Conductivity measurement**

- Ionic mobility
- Cell construction and constant
- Temperature compensation
- Conductivity measurement of high purity water
- 4-electrode sensor
- Installation
- Sensor maintenance
- Preventative maintenance

### **Module 4– Dissolved Oxygen measurement**

- Measuring cells
- Calibration
- Installation and troubleshooting
- Electrode maintenance and storage

### **Module 5–Gas Chromatography**

- Introduction
- Gas supply and pressure control
- GC Columns
- GC Detectors
- Troubleshooting

## **I07-Advanced Process Control**

### **Introduction:**

This course will provide the foundation which will allow a process control engineering to make appropriate use of all technologies available.

For those who select or design process control strategies, this course also provides a thorough background in feedback control, plus a working knowledge of the application of advanced regulatory control strategies such as ratio, cascade, feed forward, override and decoupling. The course emphasizes the benefits of advanced regulatory control for improving the economics of process operations.

### **Who Should Attend?**

Instrument or process control engineers and technicians .

### **Course Duration:**

5 Days

### **Major Topics:**

Module 1 – Feedback Control

Module 2 – Process Control Modes

Module 3 – Process control

Module 4 – Controller Tuning

Module 5 – Advanced Control Strategies

### **Course Outlines:**

#### **Module 1 – Feedback Control**

- Single feedback loop
- Advanced feedback loop
- Cascade control loop
- Feedforward control loop

## **Module 2 – Process Control Modes**

- Discrete Control
- Continuous Control
- PI control
- PID control

## **Module 3 – Process control**

- Process control symbols and diagrams
- Control loop block diagrams
- Determining process gain
- Set a controller for direct or reverse action
- Process Control Loop Characteristics
- Steady State Characteristics
- Dynamic Characteristics
- Characteristics of Flow, Temperature, Pressure & Level Loops
- Feedback Control: Behavior and terminology of proportional, integral and derivative modes

## **Module 4 – Controller Tuning**

- Controller Tuning
- Open and closed loop methods
- intelligent trial-and-error tuning
- Commercially available tuning aids
- Recognizing the difference between a control tuning problem and other control loop issues

## **Module 5 – Advanced Control Strategies**

- Basic concepts
- Design
- Implementation
- tuning

- benefits
- application examples
- Considerations for Plant-wide Control Strategies



## **I08-Integrated Control Systems**

### **Introduction:**

Integrated control system (ICS) is a general term that encompasses several types of control systems used in industrial production, including supervisory control and data acquisition (SCADA) systems, distributed control systems (DCS), and other smaller control system configurations such as programmable logic controllers (PLC) often found in the industrial sectors and critical infrastructures.

### **Who Should Attend?**

Instrument or process control engineers and technicians .

### **Course Duration:**

10 Days

### **Major Topics:**

Module 1 – Introduction

Module 2 – DCS

Module 3 – PLC/SCADA

Module 4 – Safety Instrumented System

Module 5 – Foundation Fieldbus terminology and technology

### **Course Outlines:**

#### **Module 1 – Introduction**

- Definitions
- DCS versus SCADA versus PLCS
- DCS versus SIS

#### **Module 2 – DCS**

- Main differences between a distributed control system and PLC/SCADA systems.
- Requirements of the operator interface within the DCS.
- Layout of DCS system network architecture.
- DCS Hardware
- DCS software and interface
- Redundancy in the DCS.
- Diagnostics in DCS
- Alarm Management System for DCS
- Archiving and Events in DCS
- Communication for DCS
- DCS reporting
- DCS Configuration
- DCS programming
- DCS security
- DCS maintenance and troubleshooting
- DCS backup and Healthy check
- Recovery of a DCS following a power outage
- Comparison of offering from different DCS vendors
- DCS specifications
- Typical applications and case studies

### **Module 3 – PLC/SCADA**

- Comparison of SCADA, DCS, PLC and Smart Instruments
- SCADA system hardware
- Typical SCADA installation
- Remote Terminal Unit (RTU) structure
- PLC's used as RTU
- Communication architecture
- SCADA system software
- SCADA system design
- HMI configuration
- Alarming and reporting philosophies
- Good installation practice
- Landline media

- Wide Area Network (WAN)
- Local Area Network (LAN)
- SCADA Network Security
- SCADA troubleshooting and maintenance
- SCADA specifications
- Typical applications and case studies

#### **Module 4 – Safety Instrumented System**

- Introduction
- Definition of SIS and its Functions
- Components
- Layers of Protection
- Hazard and Risk management
- Failure rates
- Fail safe and Fail Danger
- Voting System
- Sharing of Final Control Element
- Redundancy
- Diversity
- Diagnostics
- Documentation and Proof testing
- Safety standard and certification
- Safety Integrity Level
- HIPPS
- SIS software
- SIS hardware
- SIS override and simulation
- SIS maintenance and troubleshooting
- SIS programming
- Management of change
- Impact of field devices on safety integrity
- Specification & arrangement of sensors for safety duties
- Safety transmitters & Smart transmitters in safety applications
- Guidelines for final elements
- Installation aspects of emergency shutdown valves

- SIS specifications
- Typical applications and case studies

### **Module 5 – Foundation Fieldbus terminology and technology**

- Definitions
- Plant hierarchy
- Signal transmission technology
- Foundation Fieldbus H1 and High Speed Ethernet (HSE) networks
- Comparison of other industrial bus protocols
- Cost savings and operational benefits of Foundation Fieldbus technology
- Configuration and operation of a Foundation Fieldbus H1 segment
- Wiring of a Foundation Fieldbus H1 segment
- Physical Layer
- Data link layer
- Application layer
- Scheduled communication
- unscheduled communication
- Live list maintenance
- Time synchronization
- Function Blocks
- Resource Blocks
- Transducer Blocks
- FF-SIF
- Typical applications and case studies

## **I09-Practical Alarm Management Systems**

### **Introduction:**

This course will give you the necessary information to ensure that your alarm system is well designed and provides you operators with the best picture of the operations of the plant. The workshop focuses on simple and practical information for personnel ranging from operators all the way up to supervisors, engineers and managers.

### **Who Should Attend?**

Instrument or process control engineers and technicians .

### **Course Duration:**

5 Days

### **Major Topics:**

Module 1 – Fundamental Principles of Alarm System Management

Module 2 – Design Overview

Module 3 – Management of Improvement Program

### **Course Outlines:**

#### **Module 1 – Fundamental Principles of Alarm System Management**

- Definitions
- Philosophies of alarm management
- Audit the current alarm status

#### **Module 2 – Design Overview**

- Human and ergonomic factors
- Structure of good alarm system
- Safety Integrity Level (SIL)

#### **Module 3 – Management of Improvement Program**

- Alarm review

- Elimination of spurious alarms
- Process alarms
- Intermittent and fleeting alarms
- Control of modifications

# **I10-Safety Instrumentation and Emergency Shutdown System**

## **Introduction:**

This course will give you the necessary information to achieve understanding of the latest safety instrumentation practices and their applications to functional safety in manufacturing and process industries.

## **Who Should Attend?**

Instrument or process control engineers and technicians .

## **Course Duration:**

5 Days

## **Major Topics:**

Module 1 – Introduction

Module 2 – Safety instrumented System

## **Course Outlines:**

### **Module 1 – Introduction**

- Definitions
- DCS versus SCADA versus PLCS versus SIS

### **Module 2 – Safety instrumented System**

- Definition of SIS and its Functions
- Components
- Layers of Protection
- Hazard and Risk management
- Failure rates
- Fail safe and Fail Danger
- Voting System
- Sharing of Final Control Element
- Redundancy

- Diversity
- Diagnostics
- Documentation and Proof testing
- Safety standard and certification
- Safety Integrity Level
- HIPPS
- SIS software
- SIS hardware
- SIS override and simulation
- SIS maintenance and troubleshooting
- SIS programming
- Management of change
- Impact of field devices on safety integrity
- Specification & arrangement of sensors for safety duties
- Safety transmitters & Smart transmitters in safety applications
- Guidelines for final elements
- Installation aspects of emergency shutdown valves
- SIS specifications
- Typical applications and case studies



# **I11- Distributed Control Systems ‘DCS’ operation maintenance and troubleshooting**

## **Introduction:**

To be familiar with DCS systems and understand their basic operation. You want to be able to programming DCS using basic instructions programming and to understand architecture of DCS.

## **Who Should Attend?**

Instrument or process control engineers and technicians .

## **Course Duration:**

5 Days

## **Major Topics:**

Module 1 – Introduction

Module 2 – DCS Main components

Module 3 – Data Communication System

Module 4- Programming of DCS systems

Module 5- Maintenance and troubleshooting of DCS systems

## **Course Outlines:**

### **Module 1 – Introduction**

- Basic DCS specifications
- Advantages of DCS
- DCS selection criteria

### **Module 2 – DCS Main Components**

- DCS architecture
- DCS main Components
- DCS controller configuration

### **Module 3 – Data Communication System**

- Basic communications principles.
- ModBus protocol
- HART protocol
- The promise of FieldBus and DeviceNet

### **Module 4- Programming of DCS systems**

- Functions and function blocks
- Local and global variables
- Sequential function chart (SFC)
- Action control function block

### **Module 5- Maintenance and troubleshooting of DCS systems**

- Maintenance requirements of system and system elements
- The requirements for in-built diagnostics and for maintenance diagnostic routines
- The requirements for installation of UPS system
- Recovery of a DCS following a power outage

## I12-Programmable Logic Controllers (PLCs)

### Introduction:

To be familiar with PLCs systems and understand their basic operation. You want to be able to programming PLC using basic instructions programming and to understand architecture of PLC.

### Who Should Attend?

Instrument or process control engineers and technicians .

### Course Duration:

5 Days

### Major Topics:

Module 1 – Introduction

Module 2 – PLC Software

Module 3 – PLC architecture

Module 4 –Basic Instruction Programming

Module 5- Maintenance and troubleshooting of PLC systems

### Course Outlines:

#### **Module 1 – Introduction**

- PLC block diagram of components
- PLC processor module and memory organization
- PLC input/output modules
- Power supplies
- Good installation practice

#### **Module 2 – PLC Software**

- Methods of representing logic
- Boolean algebra

- Instruction code
- Graphical representation: functional logic diagrams and ladder logic
- Ladder logic instruction set (coils and contacts/timers/counters)
- Advanced instructions (program flow/ arithmetic/data transfer and PID)
- Start-up/shutdown and fault routines
- Good programming habits
- Comparison of different manufacturers

### **Module 3 – PLC architecture**

- PLC architecture and methods of communications.

### **Module 4- Basic Instruction Programming**

- Concept of Programming
- Programming using Ladder diagram
- Programming using Instruction List
- Programming using Structured Text
- Modifying an existing program
- Modifying a program to trap problems

### **Module 5- Maintenance and troubleshooting of PLC systems**

- Maintenance requirements of system and system elements
- The requirements for in-built diagnostics and for maintenance diagnostic routines
- The requirements for installation of UPS system
- Recovery of a PLC following a power outage

## **I13-SCADA Systems for Process control**

### **Introduction:**

This course is designed to provide a thorough understanding of the fundamental concepts and the practical issues of SCADA systems. Particular emphasis has been placed on the practical aspects of SCADA systems with a view to the future.

### **Who Should Attend?**

Instrument or process control engineers and technicians .

### **Course Duration:**

5 Days

### **Major Topics:**

Module 1 – Introduction

Module 2 – SCADA Main components

Module 3 – Data Communication System

Module 4–Application of SCADA systems

### **Course Outlines:**

#### **Module 1 – Introduction**

- Basic SCADA specifications
- Advantages of SCADA
- SCADA selection criteria

#### **Module 2 – SCADA Main Components**

- SCADA architecture
- SCADA main Components
- RTU
- MTU
- SCADA system software
- SCADA system design

### **Module 3 – Data Communication System**

- Communication architectures.
- Communication philosophies
- Polled (or master slave)
- CSMA/CD system (peer-to-peer)
- Landline media
- Wide Area Network (WAN)
- Local Area Network (LAN)
- SCADA Network Security

### **Module 4- Application of SCADA systems.**

- Different application of SCADA systems

# **I14-Boiler Control and Instrumentation for Engineers and Technicians**

## **Introduction:**

This course introduces the basic practices of controls systems and safety controls for industrial steam generating boilers. It focuses on the control and safety requirements applicable to most types of boilers from small gas-fired units to large multi-fuel installations. Burner management systems are introduced with their principal features including flame safety systems. The essential safety requirements for boilers and burners are identified and the corresponding safety interlocks are explained as practical solutions in accordance with the latest safety standards.

## **Who Should Attend?**

Instrument or process control engineers and technicians .

## **Course Duration:**

5 Days

## **Major Topics:**

Module 1 – Essentials of Boiler Process

Module 2 – Instrumentation relevant to boiler

Module 3 – Feed water and drum level control

Module 4–Furnace air and draft control

Module 5 – Combustion Control

Module 6 – Burner Management System

Module 7 – Steam temperature control

Module 8 –Steam Pressure and boiler load controllers

## **Course Outlines:**

## **Module 1 – Essentials of Boiler Process**

- Objective of boiler controls
- Overview of boiler types
- Boiler processes in block diagrams to show keys inputs and output variables
- Hazards of boiler operations
- The main control functions in boiler furnaces

## **Module 2 – Instrumentation relevant to boiler**

- Principles of sensors and transmitters with examples of boilers  
Closed loop control principles including feedback, feedforward, ratio and limiting.
- Control system hardware and software tools.
- Safety instrumented controls and the impact of IEC 61511
- Instrumentation diagrams and symbols per ISA and SAMA
- Distributed control systems and the separation of safety systems

## **Module 3 – Feed water and drum level control**

- Performance requirements: Level, quality, stability
- Characteristic responses of drum level
- Level control solutions, 1,2 and 3 element types
- Level measurement problems and practices
- Drum level safety systems

## **Module 4 –Furnace air and draft control**

- Performances requirements; pressures and temperatures
- Characteristic responses and means of control
- Pressure measurement methods and the pressure profile
- Temperature control and the impact of dew point
- Protection against implosion

## **Module 5 – Combustion Control**

- The combustion process and its requirements for efficiency and safety



- Coal, oil and gas firing types
- Stoichiometric air and excess air requirements
- Fuel-air ratio control and its measurements
- Firing rate controls and cross limiters for improving dynamic response
- Methods for measurements of boiler efficiency using analyzers
- Application of optimizing controllers

### **Module 6 – Burner Management System**

- Safety and performance requirements of pulverizers, burners and igniters
- Furnace safety standards and regulations
- Flame monitors and flame failure detection
- Start up protection and sequencing
- Furnace supervisory controls and shutdown systems

### **Module 7 – Steam temperature control**

- Essential control requirements
- De-superheater controls

### **Module 8 – Steam Pressure and boiler load controllers**

- Pressure and flow response characteristics
- Single boiler load control
- Multiple boiler installations and load sharing controls

# **I15-Functional Specifications for PLCs, DCSs and SCADA systems**

## **Introduction:**

This course will be useful to both specifiers and implementers and will provide a theoretical grounding as well as a practical guide for preparing a control system functional specification for implementation on Industrial control systems consisting of PLC (Programmable Logic Controllers), HMI (Human Machine Interfaces/SCADA devices) or DCS (Distributed Control Systems).

## **Who Should Attend?**

Instrument or process control engineers and technicians .

## **Course Duration:**

5 Days

## **Major Topics:**

Module 1 – Functional Specification Introduction

Module 2 – Standards and codes

Module 3 – Data communication requirements

Module 4– Graphical user interface requirements

## **Course Outlines:**

### **Module 1 – Functional Specification Introduction**

- Overview of a Functional Design Specifications (FDS)
- The terms and abbreviations
- Naming conventions and standards
- Control philosophy needed in guiding the FDS

### **Module 2 – Standards and codes**

- Discussion of relevant standards

- Definitions, tagging and naming

### **Module 3 – Data communication requirements**

- Options for different communication media
- Suitability of protocols and relevant standards
- RS-485/Ethernet/DNP3/IEC 61850 Level measurement problems and practices

### **Module 4 – Graphical user interface requirements**

- Process diagrams, modern trends and alarm systems
- Alarms including colour coding, audio indicators and others
- Different kinds of reporting

## **I16-Instrumentation Installation in Hazardous Areas and Equipment Selection**

### **Introduction:**

This course provides a detailed, systematic approach to specifying and implementing instrumentation in hazardous locations. Related standards from National Fire Protection Association (NFPA), National Electrical Manufacturers Association (NEMA), International Electro technical Commission (IEC), American Petroleum Institute (API), and ISA are discussed.

### **Who Should Attend?**

Instrument or process control engineers and technicians .

### **Course Duration:**

5 Days

### **Major Topics:**

Module 1 – Introduction

Module 2 – Location Classification Standards

Module 3 – Protection Techniques Standards

Module 4 – Explosion Proof Enclosures

Module 5– Intrinsic Safety

Module 6– Pressurization & Purging

Module 7– Other Types of Protection

Module 8- Maintenance Considerations

Module 9- Case Studies

### **Course Outlines:**

**Module 1 – Introduction**

- Steps to Safety - Classify
- Steps to Safety - Specify, Install, Maintain
- Other Safety Considerations
- Basic Definitions
- Fire and Explosion Triangle
- Flammable Properties of Gases
- Ignition Sources
- Gas/Air Mixtures
- Flammable Properties of Liquids

## **Module 2 – Location Classification Standards**

- NFPA Standards
- API Standards
- ISA Standards

## **Module 3 – Protection Techniques Standards**

- NFPA Standards - NFPA 70
- NEMA and UL Standards
- ISA Standards

## **Module 4 – Explosion Proof Enclosures**

- Applicable Standards
- Explosion Confinement
- Salient Features
- Explosion in Approved Equipment
- Threaded Joint
- Non-Threaded Joint
- Conduit Seals
- Cable Seals
- Pressure Piling
- Pressure - Time Curves
- Installation Requirements
- Equipment Classification Marking
- Installation & Maintenance Notes

## **Module 5 – Intrinsic Safety**

- Applicable Standards
- Intrinsic Safety
- Salient Features
- Field Wiring
- Faults
- Intrinsically Safe System
- Electrical Apparatus and the Intrinsic Safety Concept.
- Simple Apparatus
- Application in The Division Classification System
- Application in The Zone Classification System
- Design Requirements
- Protective Components
- Example of Energy Limitation in Associated I.S. Apparatus (Zener Barrier)
- Example Blocking Diodes in Intrinsically Safe Apparatus
- Where Are Creepage and Distances Required?
- Creepage Distance
- Clearance Distance
- Distance Through Compound or Insulation
- Creepage and Clearance Distance Table
- Associated Apparatus Design
- Ignition Curves
- Resistive Ignition Curve
- Resistive Ignition Curve
- Capacitive Ignition Curve
- Inductive Ignition Curve
- Entity Concept
- Entity Parameters for Associated Intrinsically Safe Apparatus
- Control Drawings
- Control Drawing Example
- Typical Control Drawing Notes
- Intrinsic Safety for Explosive Dust Atmospheres
- Class II / III, Division 1, Zone 20 & 21
- Intrinsic Safety in Combustible Dust Atmospheres
- Hazardous Location Marking

- NEC 504 Installation
- NEC 504 Installation (cont'd)
- Intrinsically Safe Barrier installation
- Intrinsically Safe Installation
- Wiring Configurations to Field
- Wiring Configuration Between Control Areas
- Panel Arrangement - Wireway 1
- Panel Arrangement - Wireway 2
- Suggested Panel Wiring Arrangement
- Thermocouple Barrier
- RTD Barrier
- Switch Barrier
- Transmitter Barrier
- Wiring
- International Unit Prefixes
- External Wiring Limits - Inductance
- External Wiring Limits - Inductance (cont'd)
- Entity Concept and Wiring Calculations
- Intrinsically Safe and Associated Intrinsically Safe Apparatus  
Entity Example
- Associated Apparatus Example & Wiring Calculation 1 (cont'd)
- Determining Maximum Cable Length Using Assumed Cable  
Values
- Alternate Cable Length Calculation in Meters using the L/R Ratio
- L/R Ratio Example Calculation (cont'd)
- Using the L/R Ratio
- Classroom Example - Wiring Calculation
- FISCO

## **Module 6 – Pressurization & Purging**

- Pressurized Enclosures
- Salient Features
- Types X, Y, & Z
- Blower Purging
- Plant Air Purging
- Control Rooms

- Control Room Ventilation
- Continuous Dilution (Purging)

### **Module 7 – Other Types of Protection**

- Increased Safety “e”
- Encapsulation “m”
- Powder Filling “q”
- Oil Immersion “o”
- Fiber Optics

### **Module 8 – Maintenance Considerations**

- Inspection and Maintenance
- Installation & Maintenance Notes
- Visual Inspection – Intrinsic Safety
- Electrical Safety Checks – Intrinsic Safety
- Maintenance in Hazardous Locations

### **Module 9 – Case Studies**

- Onshore Plant
- Offshore Facilities



## I17-Tuning of Industrial Control Loops

### Introduction:

Controllers need to be carefully matched to the process to work optimally; this matching procedure is called tuning. Controllers that are not correctly configured and tuned will not perform optimally and will not reduce variability in the process as they should.

### Who Should Attend?

Instrument or process control engineers and technicians .

### Course Duration:

5 Days

### Major Topics:

Module 1 – Fundamentals of loop tuning

Module 2 – The different tuning rules

Module 3 – Tuning of valves

Module 4 – Tuning of more complex systems

Module 5– Good Practice

### Course Outlines:

#### **Module 1 – Fundamentals of loop tuning**

- Processes, controllers and tuning
- PID controllers - P, I and D modes of operation
- Load disturbances and offset
- Speed, stability and robustness
- Gain, dead time and time constants
- Process noise
- Feedback controllers
- How to select feedback controller modes
- Open loop characterization of process dynamics

- Default and typical settings
- General purpose closed loop tuning method
- Quick and easy open loop method
- Fine tuning for different process types
- Simplified lambda tuning

### **Module 2 – The different tuning rules**

- Different rules compared
- Typical tuning settings
- When to use them/when not to use them
- Rules of thumb in tuning

### **Module 3 – Tuning of valves**

- Hysteresis
- Characteristic selection and correction
- Positioner configuration and tuning

### **Module 4 – Tuning of more complex systems**

- Cascade systems - tuning of them
- Feedforward, ratio, multivariable systems
- Interactive loops tuning
- Dead time compensation
- Practical limitations

### **Module 5– Good Practice**

- Good practice for common loop problems
- Flow control loop characteristics
- Level control loop characteristics
- Temperature control loop characteristics
- Pressure control loop characteristics
- Other less common loops

## **I18-Practical Fundamentals of OPC**

### **Introduction:**

OPC has come a long way in making the engineers' dream of plug and play compatibility in automation engineering achievable. OPC is an industry-wide standard that breaks this proprietary lock by allowing open connectivity based on the principles adapted from widely accepted and applied Microsoft Windows integration standards. OPC capabilities have been demonstrated in many practical applications and it is now a well-established approach for different competing manufacturers. It is now easily considered to be the standard interface in the windows environment. If you are serious about reducing your costs of installing and maintaining your automation systems you need to use OPC.

### **Who Should Attend?**

Instrument or process control engineers and technicians .

### **Course Duration:**

5 Days

### **Major Topics:**

Module 1 – Concepts and definitions

Module 2 – OPC overview

Module 3 – COM & DCOM

Module 4 – OPC Specification

Module 5– Communication Issues

Module 6– Troubleshooting

### **Course Outlines:**

#### **Module 1 – Concepts and definitions**

- Classes and objects
- Clients, servers and client/server interaction
- OLE
- DDE and NetDDE

- ActiveX
- .NET

## **Module 2 – OPC overview**

- What is OPC?
- Problems addressed by OPC
- The OPC logical object model
- OPC data (sources, formats, etc)
- OPC client/server relationships
- Current OPC specifications

## **Module 3 – COM & DCOM**

- What is COM?
- COM basics
- Setting up DCOM (programmatically or declaratively)

## **Module 4 – OPC Specification**

- OPC DA
- OPC common information
- OPC alarms and events
- OPC batch
- OPC data exchange (DX)
- OPC historical data access
- OPC security
- OPC XML-DA

## **Module 5– Communication Issues**

- Networking protocols
- LANs, WANs
- OSI Model
- Network infrastructure (Ethernet)
- ‘Transports’ (TCP/IP)

## **Module 6– Troubleshooting**

- DCOM protocol stack
- Physical and data link layer problems
- Network and transport layer problems
- COM/DCOM-related problems
- Client/server-related problems
- Simulation and conformance testing
- Error codes

## **I19-Control Valve Sizing, Selection and Maintenance**

### **Introduction:**

It is claimed that the majority of control valves throughout the world have not been correctly sized and that large numbers operate on manual mode. Whether this is true or not is difficult to establish but we do know that the method of sizing and selecting a control valve for a specific application is generally not well understood. Although there are many factors that need to be taken into account the subject is not difficult to understand if dealt with in a logical manner.

Many maintenance problems result from people treating the symptoms of a problem rather than tackling the true cause - a basic understanding of the principles is all that is usually needed to solve the problem for good.

### **Who Should Attend?**

Instrument or process control engineers and technicians .

### **Course Duration:**

5 Days

### **Major Topics:**

Module 1 – Introduction to control valve theory

Module 2 – Different types of control valves

Module 3 – Characteristics

Module 4 – Valve sizing using computer programs

Module 5– Actuators

Module 6– Positioners

Module 7– Installation and Maintenance

### **Course Outlines:**

#### **Module 1 – Introduction to control valve theory**

- Introduction and definitions
- Energy types
- What happens inside a control valve

- Cavitation and flashing
- Choked flow
- Valve co-efficient CV

## **Module 2 – Different types of control valves**

- Globe valves
- Butterfly
- Eccentric disk
- Ball
- Rotary plug
- Diaphragm and pinch

## **Module 3 – Characteristics**

- Equal percent
- Linear
- Quick opening
- Selection method

## **Module 4 – Valve sizing using computer programs**

- Water – pump bypass
- Steam – turbine bypass
- Gas – pressure reducing
- Oil – choke valve

## **Module 5– Actuators**

- Pneumatic
- Hydraulic
- Electric
- Sizing on rotary valves and linear valves
- Mounting considerations
- Manual over-rides
- Accessories

## **Module 6– Positioners**

- Basic principles
- Conventional pneumatic
- Conventional electro-pneumatic
- Smart positioners
- Feedback options

## **Module 7– Installation and Maintenance**

- Installation, commissioning and routine maintenance
- Fault finding
- Modes of failure



# **I20-Safety Relief Valves: Inspection, Operation and Troubleshooting**

## **Introduction:**

A safety or safety relief valve can be considered the most important single safety device on a boiler, piping, pipeline or pressure vessel. If it fails to function in the manner for which it was intended and an overpressure condition develops, the result could be catastrophic; this course will increase the participant's awareness and understanding about Safety Relief Valve Inspection, Maintenance, Operation, Troubleshooting and Repair.

## **Who Should Attend?**

Mechanical, Electrical engineers and qualified technicians.

Quality Control and Technical Supervisory personnel involved in pressure relief valve repair, inspection, operation or maintenance.

## **Course Duration:**

5 Days

## **Major Topics:**

Module 1 – Introduction

Module 2 – Terminology

Module 3 – Codes and Standards

Module 4 – Design & Operation Fundamentals

Module 5– Valve Sizing and Selection

Module 6– Repair and Troubleshooting

Module 7– Inspection and Maintenance

## **Course Outlines:**

## **Module 1 – Introduction**

- Purpose
- Layers of protection
- The Rule of PSV

## **Module 2 – Terminology**

- General
- Types of Devices
- Parts of Pressure Relief Devices
- Dimensional Characteristics
- Operational Characteristics
- System Characteristics

## **Module 3 – Codes and Standards**

- American Society of Mechanical Engineers
- International Organization for Standardization
- European Union Directives
- American Petroleum Institute
- National Fire Protection Agency
- National Board of Boiler and Pressure Vessel Inspectors

## **Module 4 – Design & Operation Fundamental**

- Direct Acting Pressure Relief Valves
- Pilot Operated Pressure Relief Valves
- Inlet pipe considerations
- Advantages and Limitations of Valve Types

## **Module 5– Valve Sizing and Selection**

- Procedure

- Pressure Relief Valve Nozzle Coefficient of Discharge
- Gas/Vapor Sizing
- Liquid Sizing

### **Module 6– Repair and Troubleshooting**

- Corrosion
- Damaged Seating Surfaces
- Failed Springs
- Improper Setting and Adjustment
- Plugging and Sticking
- Misapplication of Materials
- Improper Location, History, or Identification
- Rough Handling
- Improper Differential Between Operating and Set Pressures
- Improper Discharge Piping Test Procedures
- Improper Handling, Installation, and Selection of Rupture Disks

### **Module 7– Inspection and Maintenance**

- Reasons for Inspection and Testing
- Shop Inspection/Overhaul
- Visual On-stream Inspection
- Inspection Frequency
- Time of Inspection

## **I21- Fire and Gas Detection systems**

### **Introduction:**

Fire and gas detection and suppression system design techniques that are currently in use are often considered to be unsatisfactory due to their nature of being rule of thumb and experience-oriented without any real ability to quantify risk. This has resulted in systems that are either overdesigned or under-designed. Only after the ISA TR 84.00.07, was a comprehensive framework for performance-based fire and gas design established.

### **Who Should Attend?**

Control Systems Engineers; Fire and Gas System Specialists; Process Safety Professionals and Engineering Management

### **Course Duration:**

5 Days

### **Major Topics:**

Module 1 – Introduction: Overview and Definitions

Module 2 – Fire and Gas Hazards

Module 3 – The FGS Lifecycle

Module 4 – Risk Concepts and FGS Screening Analysis

Module 5– FGS Philosophy

Module 6– Detector Technology Selection

Module 7– Zone Definition

Module 8- Selecting FGS Performance Requirements

Module 9- Detector Coverage Assessment

Module 10- FGS Safety Availability

Module 11- FGS Requirements Specifications

Module 12- FGS Performance and Testing Standards

## Course Outlines:

### **Module 1 – Introduction: Overview and Definitions**

- Examples of fire and gas systems
- Legal requirements and good engineering practices
- Performance based FGS

### **Module 2 – Fire and Gas Hazards**

- Attributes of hydrocarbon fires
- Characteristics of combustible gas releases
- Toxic gas hazards
- Other special hazards safeguarded by FGS

### **Module 3 – The FGS Lifecycle**

- Relationship to ISA/IEC Safety Lifecycle
- ISA Technical Report Concepts
- FGS Engineering Design Lifecycle

### **Module 4 – Risk Concepts and FGS Screening Analysis**

- Risk definitions
- Risk parameters effected by FGS
- Risk Model (Event Tree Analysis)
- FGS Considerations in PHA/LOPA/QRA
- FGS Screen Analysis

### **Module 5– FGS Philosophy**

- Objectives of FGS philosophy definition
- FGS philosophy elements

### **Module 6– Detector Technology Selection**

- Fire detection
- Combustible gas detection

- Toxic gas detection
- Special Topics

### **Module 7– Zone Definition**

- Objectives and guidelines for zone definition
- Area coverage versus segregation
- Site survey Routing

### **Module 8- Selecting FGS Performance Requirements**

- Performance targets based on risk
- Hazard assessment options
- Fully quantitative methods for assessment
- Semi-quantitative methods for assessment

### **Module 9- Detector Coverage Assessment**

- Fire geographic coverage
- Fire scenario coverage
- Gas geographic coverage
- Gas scenario coverage

### **Module 10- FGS Safety Availability**

- SIL versus FGS Safety Availability
- FGS function definition
- FGS safety availability calculation

### **Module 11- FGS Requirements Specifications**

- General FGS requirements
- FGS functional specifications
- Special considerations for FGS

### **Module 12- FGS Performance and Testing Standards**

- Performance standards
- Installation validation
- Performance validation
- Validation of FGS mapping

## **I22-Field Bus System: Architecture, Configuration and Applications**

### **Introduction:**

A FOUNDATION fieldbus system is a distributed system composed of field devices and control and monitoring equipment integrated into the physical environment of a plant or factory. Fieldbus devices work together to provide I/O and control for automated processes and operations. This course focuses on Basics and fundamentals of Fieldbus.

### **Who Should Attend?**

Instrumentation ,Control Systems Engineers& technician.

### **Course Duration:**

5 Days

### **Major Topics:**

Module 1 – Introduction

Module 2 – Fieldbus basics

Module 3 – Fieldbus specifications

Module 4 – Communication architecture

Module 5 – Components and wiring

Module 6 – Segment Design

Module 7 – Data link layer

Module 8 – Application layer

Module 9- Fieldbus devices and blocks

Module 10- FF- SIF

## Course Outlines:

### **Module 1 – Introduction**

- Definitions
- Plant hierarchy
- Signal transmission technology
- Comparison of communications protocols

### **Module 2 – Fieldbus basics**

- Benefits
- Multi sensing
- Hardware reduction
- Wiring savings

### **Module 3 – Fieldbus Specification**

- Basic protocol
- Physical layer specifications

### **Module 4 – Communication architecture**

- Physical Layer
- Data link layer
- Application layer

### **Module 5 – Fieldbus components and wiring**

- Terminator
- Power Supply
- Barriers
- Cables
- Mounting coupler
- Wiring Topology

### **Module 6 – Segment Design**

- Cable length calculations
- Power consumption and number of devices

### **Module 7 – Data link Layer**



- Scheduled communication
- Unscheduled communication
- Live list maintenance
- Time synchronization

### **Module 8 – Application Layer**

- FAS
- FMS
- VCR

### **Module 9 – Fieldbus devices and Blocks**

- CFDD files
- Function Blocks
- Resource Blocks
- Transducer Blocks

### **Module 10 – FF-SIF**

- Introduction
- Advantages
- Limitations

## **I23-Industrial Data Communication System**

### **Introduction:**

Starting from the basics, this course gives you the tools to design and maintain industrial communications systems on your plant floor. You'll learn the underlying principles behind today's industrial communications systems, including Modbus, Data Highway Plus, Ethernet, and TCP/IP. Real-life examples and case histories provide insight into the facts behind control networks and how to apply and maintain them effectively in your plant.

### **Who Should Attend?**

Automation, Process, control engineers.

### **Course Duration:**

5 Days

### **Major Topics:**

Module 1 – What is Data Communications?

Module 2 – Serial Communications

Module 3 – HART

Module 4 – Fieldbus

Module 5 – Data Link Layer Basics

Module 6 – Industrial Protocols

Module 7– LAN Technologies

Module 8– TCP/IP basics

Module 9– Fiber optics

Module 10 – Wireless Industrial Communications

Module 11 – Inside the Proprietary PLC Networks

Module 12 – Data Exchange using OPC

Module 13 – Troubleshooting Industrial Networks and Fieldbuses

## Course Outlines:

### **Module 1 – What is Data Communications?**

- ISO/OSI Reference Model
- Terminology Basics

### **Module 2 – Serial Communications**

- Modem Principles
- The EIA-232E Standard
- Beyond 232: EIA-422/423/485/530 Standards Ball

### **Module 3 – HART**

- Introduction
- Basics
- Benefits
- Limitations

### **Module 4 – Fieldbus**

- Introduction
- Basics
- Benefits
- Limitations

### **Module 5 – Data Link Layer Basics**

- Data Encoding
- Error Detection/Correction Schemes

### **Module 6 – Industrial Protocols**

- Modbus and Modbus/IP
- DNP3.0 and DF-1
- Profibus
- Profinet
- Profisafe

### **Module 7– LAN Technologies**

- Overview of Ethernet Technology
- Ethernet Cabling and Configuration Rules
- Repeaters
- Bridges
- Routers
- Gateways

#### **Module 8– TCP/IP basics**

- Is Ethernet Ready for the Plant Floor?
- Industrial Ethernet Design Techniques

#### **Module 9– Fiber optics**

- Standards
- Cables
- Applications
- limitations

#### **Module 10 – Wireless Industrial Communications**

- SP100
- Wireless HART
- Wireless Fieldbus
- Wireless Profibus

#### **Module 11 – Inside the Proprietary PLC Networks**

- MB+ and DH+ LAN design

#### **Module 12 – Data Exchange using OPC**

- Introduction
- Basics
- Benefits
- Limitations

#### **Module 13 – Troubleshooting Industrial Networks and Fieldbuses**

- Five Rules for Troubleshooting
- Troubleshooting with Statistics
- Troubleshooting Tools Benefits

## **I24-Applying Standard Instrumentation and Control Documentation**

### **Introduction:**

This course will present the methodology for the designing and developing control systems documentation. The development of piping and instrument diagrams (P&IDs) and related ISA drawings are emphasized. This course covers both the development and the reading/interpreting of these documents, making it beneficial to engineers, designers, software programmers, system integrators, and technicians.

### **Who Should Attend?**

Instrument or process control engineers and technicians .

### **Course Duration:**

5 Days

### **Major Topics:**

Module 1 – P&IDs

Module 2 – Instrument Lists

Module 3 – Control System Software

Module 4 – Logic Diagrams

Module 5– Installation Details

Module 6– Location Plans

Module 7– Loop Diagrams

Module 8- Control Methods

Module 9- Standards and Documentation

### **Course Outlines:**

#### **Module 1 – P&IDs**

- Requirements

- Definition and Use
- ISA Standard Symbols and Identification
- Contents and Piping Information
- Design and Construction
- Developing from Flow Diagrams
- Scheduling Considerations
- Hazardous Area Considerations

### **Module 2 – Instrument Lists**

- Definition and Use

### **Module 3 – Control System Software**

- PLC/DCS Functional Requirement Documentation Development

### **Module 4 – Logic Diagrams**

- Definition and Use
- Symbolology
- Interpretation
- ISA Standards

### **Module 5– Installation Details**

- Use
- Development
- Materials of Construction
- Valves
- Scheduling

### **Module 6– Location Plans**

- Purpose and Development
- Structural Considerations
- Electrical and Other Trays
- Panel Location

### **Module 7– Loop Diagrams**

- Purpose
- Interpretation

- Development
- ISA Standards
- Scheduling Considerations

### **Module 8- Control Methods**

- Feedback
- Feedforward
- Ratio
- Cascade
- Control Valves

### **Module 9- Standards and Documentation**

- Symbols
- ISA5.1 - ISA5.6
- ISO 9000
- OSHA
- Process Safety System Management
- API 750

## **I25-Selection, Calibration, Maintenance and Troubleshooting for Field Devices and Control Systems**

### **Introduction:**

This Course focuses on applying correct practice to installation, calibration and maintenance of instruments and learning how to:

- Calibrate electronic transmitters and controllers
- Configure instruments correctly to vendor instruction sheets
- Apply Intrinsic safety techniques to instrumentation installation
- Maintain instruments correctly
- Connect instrument wiring correctly
- Predict and avoid the problems with installing measurement equipment
- Troubleshoot, isolate and fix electronic instrumentation problems
- Specify instrument and loop documentation requirements and standards to vendors
- Fault find with drawings
- Design and install safe working systems in hazardous areas
- Effectively apply the principles of analog meters, digital meters and oscilloscopes
- Carry out simple repair procedures for the correction of faults on instrument systems where possible

### **Who Should Attend?**

Instrument or process control engineers and technicians .

### **Course Duration:**

5 Days

### **Major Topics:**

Module 1 – Electrical Measurements

Module 2 – Instrument Performance

Module 3 – Calibration Principles

Module 4 – fundamentals of Process Measurement

Module 5 – Calibration of Transmitters



Module 6 – PID Controllers

Module 7 – Smart and Fieldbus Transmitters

Module 8 – Transducers and Transmitters

Module 9 – Instrument Documentation and P&I D's

Module 10 – Hazardous Areas

Module 11 – Maintenance, Fault Finding and Repairs of EX Equipment

Module 12 – Standards, Certification, Marking and Approval

Module 13 – Integration of the System

### Course Outlines:

#### **Module 1 – Electrical Measurements**

- Use of multimeter
- Voltage, current and resistance measurement
- Analog and digital meters
- Oscilloscopes
- Current to voltage conversion
- Multiple Loop devices
- Diodes and resistors
- Soldering and component preparation
- Open and short circuits
- Testing of diodes/DIACS/TRIACS/
- Components out of tolerance
- Isolation and earthing

#### **Module 2 – Instrument Performance**

- Basic Measurement and control concepts
- Accuracy/Range/Hysteresis/Linearity/  
Repeatability/Response/Dead Time
- Zero/Span
- Process Dynamics

- Specifications

### **Module 3 – Calibration Principles**

- Block Diagrams
- Standards for calibration
- Five Point calibration
- Charts

### **Module 4 – fundamentals of Process Measurement**

- Basic measurement concepts
- Definition of terminology
- Measuring instruments & control valves as part of the overall control system
- Pressure, level, temperature and flow overview
- Overview of control valves

### **Module 5 – Calibration of Transmitters**

- Shop calibration
- Electro pneumatic calibrators
- In-shop or Field
- Temperature - Calibration (RTD/Thermocouples)

### **Module 6 – PID Controllers**

- Direct/reverse acting
- P, I and D Control
- Spanning and Range
- Instrument/Controller and Process Gains

### **Module 7 – Smart and Fieldbus Transmitters**

- Operation
- Configuration
- Re-ranging
- Characteristics
- Trimming

## **Module 8 – Transducers and Transmitters**

- Fundamentals
- Calibration
- Interfacing to instrument

## **Module 9 – Instrument Documentation and P&I D's**

- Control Loops on the P&ID
- Instrument Lists
- Wiring diagrams
- Schedules & lists
- Data sheets
- Loop diagrams
- Standards & symbols

## **Module 10 – Hazardous Areas**

- Explosion Consequences
- Definition of Hazardous Area
- Classification of Apparatus
- Apparatus Grouping and Temperature
- Principles of Ex Protection
- Requirements for IS Systems
- Noise and Interference Control
- Earthing requirements
- Static Protection
- Lightning Protection

## **Module 11 – Maintenance, Fault Finding and Repairs of EX Equipment**

- Planned Maintenance
- Use of Tools
- Procedures
- Safe Methods
- Test equipment suitability

## **Module 12 – Standards, Certification, Marking and Approval**

- Authorities
- Marking and identification
- Apparatus Certification

### **Module 13 – Integration of the System**

- Calculation of individual instrument error and total error for the system
- Integration of the pressure, level, temperature and flow systems
- Integration of new smart subsystems with data communication links
- Procedures
- Testing and commissioning
- Start up

## **I26-Practical Hazop, trips and alarms**

### **Introduction:**

The HAZOP technique is recommended by professional engineering institutions, government regulators and insurance companies and is one of the principle risk management tools. HAZOP is applied at both the design stage and throughout the life of a process plant, where it supports the safety management and (where applicable) the validation of the plant safety case.

HAZOP is also an essential technique when reviewing modifications and upgrades to existing plant.

### **Who Should Attend?**

Instrument or process control engineers.

### **Course Duration:**

5 Days

### **Major Topics:**

Module 1 – Hazard study and risk management

Module 2 – Typical Hazop workshop

Module 3 – Examination phase methods

Module 4 – Planning and leadership of hazops

Module 5 – From hazop to SIL

Module 6 – Hazard analysis methods

### **Course Outlines:**

#### **Module 1 – Hazard study and risk management**

- The need for quality assurance in hazard studies
- The process hazard study lifecycle and the six levels of studies
- Principles of risk management

- Legal requirements for hazard studies US and EU regulatory frameworks

## **Module 2 – Typical Hazop workshop**

- Step by step introduction to the activities of a HAZOP workshop
- Timing and duration of the study
- Documents required
- Team membership and duties
- Outline of the examination phase
- Recording, reporting and follow up

## **Module 3 – Examination phase methods**

- Defining the system and selecting the parts for study
- Elements and parameters
- Generating deviations with guide words and a matrix
- Guideword examination procedures and responses
- Worked examples of continuous and batch process studies
- Control HAZOPS
- Software tools for the examination and reporting phases

## **Module 4 – Planning and leadership of hazops**

- Organizing the study, planning, scoping and objectives
- The team leader's skills and duties
- Essential members of the team and their roles
- Conducting the study sessions, dealing with problems
- Using additional checklists for operability
- Contents of the HAZOP study report
- Tips for the facilitator

## **Module 5 – From hazop to SIL**

- The relationship between hazard studies and safety instrumented systems
- Risk reduction concepts and the risk matrix
- Concepts of tolerable risk and the ALARP principle
- Layers of protection
- The role of safety instrumented systems in risk reduction

- The meaning of SIL and how it relates to safety and cost
- SIL determination methods and the input from HAZOPS

### **Module 6 – Hazard analysis methods**

- The reasons for hazard analysis
- Failure modes and effect analysis method
- Fault tree and event tree analysis methods
- Adding risk reduction measures to the fault tree

# **I27- Preparation for Functional Safety Certification “FS Engineer”**

## **Introduction:**

This course is preparation for Functional Safety Certification “FS Engineer”.

## **Who Should Attend?**

Instrument or process control engineers.

## **Course Duration:**

5 Days

## **Contents:**

- IEC 61 508 and IEC 61511 background
- Hazards
- Risk and ALARP principles
- Risk Reduction
- Safety Instrumented System (SIS) and Safety Instrumented Functions (SIF)
- Types of SIF
- Integrity specification of a SIF
- Fault Tree Analysis (FTA)
- SIL determination by FTA
- SIL determination by Qualitative Methods
- SIL determination exercises
- Layers of Protection Analysis (LOPA) and LOPA exercises
- Case of Studies with typical findings and issues.
- Integrity Specification of a SIF
- SIS Safety Requirement Specification
- Selection of Components and Subsystems
- Proven in use, Not proven in use
- Field devices
- Failures, Failure and Reliability
- Demand Modes, Probability of Failure on Demand (PFD)



- PFD Exercises
- SIF Implementation (Low demand mode)
- Importance of Testing and Maintenance
- Fractional Dead Times
- Safe Failure Fraction and Hardware Fault Tolerance, SFF
- Partial Closure Testing
- Measurement validation and Comparison
- Reliability Data.
- Software requirements
- Relationships between Hardware and Software Architecture
- Application Software Requirements Specification
- Application Software validation Planning
- Requirements for Application Software Architecture
- Requirements for Support Tools, User Manuals and
- Application language
- Requirements for Application Software Development
- Integration of Application Software with SIS Subsystems
- FPI and IVL Software Modification Procedures
- Application Software Verification
- SIF Interaction with Others Technologies
- Multiple Functions, Primary Functions, Exercises,
- Intermediate Trips
- Risk Graph Calibration,
- SIL determination for Fire and Gas
- Further lifecycle Considerations
- Methods for Solving Complex Functions

## **E01-Electrical Maintenance**

### **Course Contents Objectives:**

To give participants a course for Basics of Electrical Maintenance including Ac motors, Power transformers, switchgears, Batteries and electrical installation in hazardous area.

### **Who should attend?**

The course is designated for maintenance & operation engineers, supervisors and technicians.

### **Duration:**

5 Days (15 hrs)

### **Course outline:**

#### **Chapter 1: INTRODUCTION**

#### **Chapter 2: Motors**

- TYPES OF A. C. ELECTRIC MOTORS
- PRINCIPLES OF OPERATION OF THE INDUCTION MOTOR
- ENCLOSURES
- POWER FOR INDUCTION MOTORS
- STARTING OF INDUCTION MOTORS
- MOTOR TESTING
- INTRODUCTION TO MOTOR PROTECTION
- MOTOR FAILURES

#### **Chapter 3: TRANSFORMERS**

- POWER TRANSFORMERS CONSTRUCTION
- TRANSFORMER MAINTENANCE
- PREVENTIVE MAINTENANCE INSTRUCTIONS FOR POWER TRANSFORMERS

#### **Chapter 4: SWITCHGEAR**

- THE BREAKING OF A.C. CIRCUITS
- High Voltage Switchgear
- Low Voltage Switchgear
- SWITCHGEAR TESTING
- PREVENTIVE MAINTENANCE INSTRUCTIONS FOR LOW AND HIGH VOLTAGE SWITCH BOARDS

### **Chapter 5: BATTERIES**

- INTRODUCTION
- THE CELL
- TYPES OF CELLS
- BATTERIES
- BATTERY MAINTENANCE
- Safety Precautions with Batteries
- CAPACITY AND RATING OF BATTERIES
- BATTERY CHARGING
- BATTERY PREVENTIVE MAINTENANCE

### **Chapter 6: Hazardous Area Equipment**

- Introduction
- Area Classification
- Methods Of Production
- Life Limiting Factors
- Safety In Maintenance

## **E02-Electrical Motors**

### **Course Contents Objectives:**

To give participants a course for industrial induction AC drives applications including induction motors Types, Selection, Control, Protection and Maintenance.

### **Who should attend?**

The course is designated for maintenance & operation engineers, supervisors and technicians.

### **Duration:**

5 Days (15 hrs)

### **Course outline:**

- Electric motor history and principles
- Major motor types:
  - AC single phase (types, characteristics and equations).
  - AC poly phase (characteristics and equations)
  - Direct current motors
  - Torque speed characteristics.
- Mechanical considerations:
  - Classification of hazardous area according to IEC & NEC standards
  - Enclosure and environment
  - NEMA frame suffixes
  - Types of mounting
- Electrical characteristics and connection:
  - Volt, phase, frequency...etc.
    - Typical control circuits
- Electric motors maintenance:

- Lubrication procedure
  - Re-lubrication Interval chart
- Practical training
- Types of loads
  - Constant torque loads
  - Variable torque loads
- Recommended practice for AC motor protection
  - Types of induction motor faults
  - Induction motor protection devices
  - Other types of starting methods

## **E03-Electrical Power transformers**

### **Objectives:**

To give participants a course for industrial induction AC power transformers including construction, Types, Selection, Control, Protection and Maintenance.

### **Who should attend?**

The course is designated for maintenance & operation engineers, supervisors and technicians.

### **Duration:**

5 Days (15 hrs)

### **Course outline:**

1. Principles of Transformers
2. Saturation Curve & Voltage Ratio of Transformers
3. Current Ratio & Impedance of Transformers
4. Transformer Construction
5. Transformer losses and efficiency
6. Transformer Cooling & Types
  - 6.1 Oil Immersed Type
  - 6.2 Dry Type
  - 6.3 Methods of Cooling & Symbols
  - 6.4 Types of Cooling of Power Transformers
7. Transformer Polarity
8. Transformer Applications
9. Transformer Accessories

10. Maintaining Transformers

11. Common Transformer Abnormalities

## **E04-Electrical Generators**

### **Objectives:**

The course provides a comprehensive overview for professionals seeking for understanding the principles of power generation, control, protection, maintenance and trouble shooting of the power generators and its engine drive.

### **Who should attend?**

The course is designated for maintenance engineers, supervisors and technicians.

### **Duration:**

5 Days (15 hrs)

### **Course outline:**

- Basic information of AC power generation
  - Principle of operation.
  - Generator construction and brush less exciter
  - Field excitation and permanent magnet generators
  
- Generators winding and regulations
  - Field excitation and permanent magnet generators Proximity sensors
  - Series boost applications
  
- Speed control systems and Electronic governor
  - General information and speed control block diagram
  - Installation, operation and adjustment
  - Trouble shooting procedure
  
- Generator paralleling and load sharing
  - Synchronization conditions
  - Continuous operation adjustment



- Voltage regulations
  - Principle of operation
  - Operation, maintenance and trouble shooting
  
- Typical control and protection systems for Gas and Diesel engine sets
  - Generator and engine matching
  - Types of protection used for both engine and generator
  - Application using CAT engine control module (ECM) and Classical relays & protection devices
  
- Inspection, maintenance and trouble shooting
  - Lubrication procedure
  - Maintenance procedures and schedules.
  - Fault tracing and troubleshooting procedure.

## **E05-Batteries, Battery Chargers and UPS systems**

### **Objectives:**

To enhance the knowledge and skills of the maintenance & operation supervisors and technicians in dealing with the direct current equipment and NO BREAK systems.

### **Who should attend?**

The course is designated for maintenance & operation supervisors and technicians.

### **Duration:**

5 Days (15 hrs)

### **Course outline:**

- Types of batteries
  - Acid batteries
  - Alkaline batteries
  
- Study of Battery Characteristics at:
  - Constant current loads
  - Inrush current starting loads
  
- Maintenance of batteries
  - Electrolyte preparation
  - Commissioning, float and high rate charging
  
- Battery sizing calculations

- Operating principles of battery chargers
  
- Operating principles of UPS system
  
- Protection of direct current installation
  - Characteristics of faults
  - Choice of protective devices

## **E06-Electrical protection systems**

### **Objectives:**

The course presents the protection concepts for personnel & equipment and illustrates the different electrical faults, protection devices operating principles, selection, advantages and disadvantages. Moreover, It is focusing on the generator, motor and transformer protection.

### **Who should attend?**

The course is designated for maintenance & operation engineers and supervisors, and technicians.

### **Duration:**

5 Days (15 hrs)

### **Course outline:**

- Protection goals
  - Personnel protection
  - Equipment protection
  - Safety regulations
  - Protective Earth Conductors
- Protection systems Features
- Types of Electrical faults
  - Current faults
  - Voltage faults
- Protection devices
  - Fuses types, selection and applications
  - Circuit breakers types, selection and applications
  - Contactors types, selection and applications
  - Differential circuit breakers types
  
- Recommended electrical protection for:
  - Generators
  - Motors
  - Transformers
- Protection of direct current installation

## **E07-Electrical Control Devices**

### **Objectives:**

To give participants an introductory course for: Basics of control and protection devices including principles and overview of the applied protection and control systems Power and control cables types, construction, connection and termination

### **Who should attend?**

The course is designated for electrical engineers (recently graduated up to 5 years experience), supervisors and technicians (recently graduated up to 15 years experience).

### **Duration:**

10 Days (30 hrs)

### **Course outline:**

- Modular components types, selection and applications
  - Contactors and motor starters
  - Control relays
  - Circuit breakers
  - Fuses
  - Timer relays
  - Thermal over load relays
- Detection devices types, theory of operation and applications
  - Limit switches
  - Proximity sensors
  - Photo electric detectors
- Control devices types, theory of operation and applications
  - Pressure switches
  - Temperature switches
  - Level switches
  - Solenoid valves

- Protection and measurements auxiliaries
  - Potential transformers
  - Current transformers
  - Differential circuit breakers types
- Typical control and protection circuits applied on the oil and gas fields:
  - Direct on line motor control circuit
  - Star-Delta motor control circuit
  - Generators protection and control circuit
  - Over head cranes applications
- Power and control cables
  - Cables parameters and construction
  - Cable Ampacity and short circuit capacity
  - Voltage drop
  - Cable connection and termination
  - Cable glands types, selection and connection
  - Cable laying and testing
- Practical training

## **E08-Switchgears and Motor control Centers**

### **Objectives:**

The course provides a comprehensive overview for professionals seeking for understanding the principles, components, basic function and applications about low voltage switchgear & Power center Modules

### **Who should attend?**

The course is designated for maintenance engineers, supervisors and technicians.

### **Duration:**

5 Days (15 hrs)

### **Course outline:**

- General electric characteristics.
- Components of low voltage switchgear & Power center
  - Circuit breakers types, T/C characteristics
  - Contactors types, sizes, selection and maintenance
  - Fuses classes, characteristics and applications
  - Voltage transformer and current transformer
  - Protective relays
  - Trouble shooting procedure
- Construction characteristics of low voltage switchgear & Power center
  - Bus Bars
  - Wiring and power connections.
  - Maintenance and trouble shooting
  - Applications on hazardous and non hazardous areas
  - Trouble shooting procedure

## **E09-Electrical Installation in Hazardous area**

### **Objectives:**

The course provides a comprehensive overview for professionals seeking for understanding the principles of electrical installation in hazardous area (oil and gas plants) according to codes and standards

### **Who should attend?**

The course is designated for maintenance engineers, supervisors and technicians.

### **Duration:**

5 Days (15 hrs)

### **Course outline:**

- Non hazardous area applications.
- Ignition properties and apparatus protection
  - Defining an atmosphere with an explosion hazard.
  - Defining hazardous areas for gas and vapours.
  - Determining hazardous areas in the presence of gas and vapours
- Classification of hazardous area according to :
  - NEC standard
  - IEC standard
- Types of explosion proof protection methods:
  - Flame proof protection method
  - Increased safety protection method
  - Purged and pressurized protection method
  - Intrinsically safe protection method
  - Increased safety protection method
  - Another types of protection methods
- Permit to work system and safe isolation
- Standards and certifications



## **E10-Electrical Cables Selection, Sizing, Rout, Sections & Inspection**

### **Objectives:**

To give participants a course for Electrical Cables to increase his ability to select, maintain and test the cables in addition to know How to Design your Cable System

### **Who should attend?**

The course is designated for maintenance & operation engineers, supervisors and technicians

### **Duration:**

5 Days (15 hrs)

### **Course outline:**

- Description of Cable Systems;
- Cable Types & Materials;
- Cable Characteristics;
- Cable Selection & Specifications;
- Cable Sizing;
- Cable Installation;
- Rout, and Sections;
- Inspection & Testing Guide;
- Aging of Cable System;
- Diagnostic Techniques;
- Environmental Considerations;
- Practical Exercises & Cases.
- Application: How to Design your Cable System.

## **E11-Electrical Lighting System in Hazardous areas**

### **Objectives:**

The course provides a comprehensive overview for professionals seeking for understanding the principles of electrical installation in hazardous area (oil and gas plants) according to codes and standards

### **Who should attend?**

The course is designated for maintenance engineers, supervisors and technicians

### **Duration:**

5 Days (15 hrs)

### **Course outline:**

- PART 1:
  - Classification of hazardous area:
  - Ignition properties and apparatus protection.
  - Classification of hazardous area according to :
    - NEC standard
    - IEC standard
  - Types of explosion proof protection methods:
    - Flame proof protection method
    - Increased safety protection method
    - Purged and pressurized protection method
    - Intrinsically safe protection method
    - Increased safety protection method
    - Another types of protection methods
  - Standards and certifications
- PART 2:
  - Electrical Lighting System:
    - 2-1) Lamp selection Guide
  - Ballasts and Ballast Factor
  - Correlated Color Temperature, (CCT)
  - Color Rendering Index, (CRI)
  - Efficiency

- Candlepower Distribution
- 2-2) Lighting Design and Calculations
  
- General Procedure for Maintained Illumination and Luminance
- Recommended Levels of Illumination according to IEC standards

## **E12-Electrical High Voltage Techniques**

### **Objectives:**

To give participants a course for High Voltage Techniques to increase his ability to operate, maintain and test the high voltage equipments.

### **Who should attend?**

The course is designated for maintenance & operation engineers, supervisors and technicians.

### **Duration:**

5 Days (15 hrs)

### **Course outline:**

- Electric Fields
  - Introduction
  - Electrical Stresses Control and Optimization.
- Corona Discharge
  - Introduction
  - Mechanism of Corona Discharge.
  - Positive and Negative Corona.
  - Corona onset level and onset voltage
  - Industrial application of corona.
- High Voltage Bus Bars
  - Bus Bars Arrangement
  - Bus Conductor Materials
  - Bus bars clearance
  - Mechanical stresses on bus bar conductors.
- Circuit Breakers
  - Circuit breaker rated quantities
  - Switched current and circuits
  - Types of circuit breakers
- Grounding Systems
  
- High Voltage testing
  - Classification of tests
  - Safety precautions in the laboratory.

- Testing for electrical equipments (transformer, cables, circuit breaker, surge arrestors, Insulators...)

## **E13-Electrical Protection Systems Of electrical assets**

### **Objectives:**

To give participants a course for Electrical Protection Systems to increase his ability to operate, maintain and test the Electrical Protection Systems

### **Who should attend?**

The course is designated for maintenance & operation engineers, supervisors and technicians

### **Duration:**

5 Days (15 hrs)

### **Course outline:**

- Need for Protection;
- Fault Types & their Effects;
- Simple Calculation of Short Circuit Currents;
- System earthing;
- Protection System Components Including Fuses;
- Instrument Transformers;
- Circuit Breakers;
- Tripping Batteries;
- Co-Ordination by Time Grading:
  
- Problems in applying IDMT relays;
- Low Voltage Networks;
- Feeder Protection;
- Transformer Protection;
- Switchgear (Bus bar) Protection;
- Motor Protection;
- Generator Protection;
- Management of Protection.

## **E14- Generator Excitation Systems & AVR Selection, Commissioning, Operation, Maintenance, Testing & Troubleshooting**

### **Objectives:**

This course will provide engineers and technicians the necessary knowledge to maintain, repair and calibrate an excitation system together with the automatic voltage regulator (AVR). This includes using effective routine maintenance practices, knowing what checks may be performed on-line and how to perform these checks without causing an equipment shutdown,

### **Who should attend?**

The course is designated for maintenance & operation engineers, supervisors and technicians

### **Duration:**

5 Days (15 hrs)

### **Course outline:**

- 1- Major Generator Set Components
  - Generator Power Sources, Anatomy of a Steam Turbine
  - Generator Construction
  - Governor System's, Excitation Systems
  
- 2- Anatomy of an Excitation System
  - Excitation Configuration
  - AVR Steady State Operation
  - Excitation Protection
  
- 3- Hardware Configurations
  - Generator Dynamics
  - AVR Dynamics
  - Dynamic and Transient Stability
  
- 4- Operation of AVR systems

- Commissioning
- Operation and Troubleshooting
- Maintenance

## **5- Generator Protection**



## **E15-Electrical Equipment & Systems** **(Installation, Troubleshooting & Maintenance)**

### **Objectives:**

To give participants a course for Electrical Equipment & Systems to increase his ability to operate, maintain and test the Electrical Systems

### **Who should attend?**

The course is designated for maintenance & operation engineers, supervisors and technicians

### **Duration:**

5 Days (15 hrs)

### **Course outline:**

- Overview of Several Regulations & Standards;
- Design & Specification of Electrical Installations;
- Protection Principles & Practices;
- Earthing Requirements;
- Isolation & Switching;
- Selection & Erection of Equipments;
- Selection & Sizing of Cables;
- Special Installations & Locations;
- Inspection & Testing of Electrical Installations;
- Safety Verification of New Electrical Installations;
- Electrical Maintenance & Troubleshooting
- Strategies, Techniques, Requirements & Precautions;
- Survey of the Most Frequent Problems;

- Reliability Problems & Frequencies;
- In-Service Inspection & Testing;
- Electrical Safety & Risk Assessment;
- Employment of Electrical Contractors.

## E16-Electrical safety

### Objectives:

To enhance the knowledge and skills of the maintenance & operation supervisors and technicians in dealing with the *electrical safety*.

### Who should attend?

The course is designated for maintenance & operation supervisors and technicians.

### Duration:

5 Days (15 hrs)

### Contents:

Section –1 Safety in Industrial Power Systems

Section –2 Standard Requirements:

A-Safety Related to Work Practices

- A.1 General Requirements
- A.2 Personal and Other Protective Equipment
- A.3 Specific Related work Practices

B-Safety Related Maintenance Requirements

- B.1 Substation and Switchgear Assemblies
- B.2 Premises Wiring
- B.3 Control Equipment
- B.4 Fuse & Moulded-case Circuit Breakers
- B.5 Rotating Electrical Equipment
- B.6 Safety and Protective Equipment

C- Lockout-Tag out & Isolation

- C.1 General Requirement
- C.2 Procedural Requirements

### C.3 Tagging

#### D-Working Areas Requirements

D.1 On-Site Electrical Safety

D.2 On-Site safety Kit

D.3 Working Area control

Section –3 Powered Hand Tools and Portable Equipment

Section –4 Earthing and Bonding

Section –5 Safety Aspects for Some Other Equipment

Section –6 Hazardous Areas and Electric Equipment

Section –7 Electrical Shocks

Section –8 Electrical Permit to Work System

Section –9 Electricity Impacts on the Environments

Section –10 Summary

## **E17-Grounding in Electrical Systems & Noise Reduction in Instrument Loops**

### **Objectives:**

To give participants a course for Grounding in Electrical Systems to increase his ability to operate , maintain and test the Grounding Systems in addition to reduce the instruments loops noise levels

### **Who should attend?**

The course is designated for maintenance & operation engineers, supervisors and technicians

### **Duration:**

5 Days (15 hrs)

### **Course outline:**

- Introduction to Grounding;
- Grounding Electrical Systems;
- Ground Loops in Instrumentation;
- Standards for Grounding Instrument Systems;
- Comparing Noise & Interference;
- How Noise & Interference are transmitted;
- Identifying Instrument Signal Wiring & Conductors;
- Shielding & Grounding Methods in Instrumentation;
- Effects of Harmonics on Power Systems & Control Systems.

## E18-Variable Speed Drives

### Protecting & Increasing the Performance

#### Objectives:

To give participants a course for Variable Speed Drives to increase his ability to select, maintain and Increase their Performance

#### Who should attend?

The course is designated for maintenance & operation engineers, supervisors and technicians

#### Duration:

5 Days (15 hrs)

#### Course outline:

- Why & When to Use VSD.
- Overview to VSD Selection, Installation, Protection, Maintenance & Troubleshooting,
- Drive Installation Requirements: *New & Retrofit Applications*
- Drive Protection from Power Line Disturbances, Voltage Transients, High Fault (Surge) Currents, Capacitance Coupling and Over voltage Tripping
- Filtering Techniques for Drives
- Motor Protection from Shorted Windings, Insulation Breakdown, High voltage Spikes and Retrofits
- Motor Conductor Protection from  
Insulation Breakdown, High Voltage Spikes and Long Lead Applications
- Cable Lengths and Terminations
- Harmonics and Drives

## **E19-Uninterruptible Power Supply (UPS)**

### **Installation, Operation & Troubleshooting**

#### **Objectives:**

To enhance the knowledge and skills of the maintenance & operation supervisors and technicians in dealing with the direct current equipment and NO BREAK systems.

#### **Who should attend?**

The course is designated for maintenance & operation supervisors and technicians.

#### **Duration:**

5 Days (15 hrs)

#### **Course outline:**

- UPS Overview;
- SCR-Thyristor;
- AC to DC Charger;
- Commissioning, Energisation & Operation;
- SCR Control Board;
- Load sharing;
- Low Voltage & High Voltage DC Relay;
- Equalize Timer Operation;
- DC to AC Inverter;

- UPS Installation;
- Operation Procedures;
- Common Problems & Troubleshooting.



## **E20-Power factor correction and Harmonics Filtering**

### **Objectives:**

The course describes the importance of power factor and its effect on the plant electrical grid. Also, the recommended techniques for power factor improvement including the selection, installation, maintenance and protection of capacitor banks.

### **Who should attend?**

The course is designated for maintenance & operation engineers, supervisors and technicians.

### **Duration:**

5 Days (15 hrs)

### **Course outline:**

- I) Typical Power factor for different electrical loads
  - Motors
  - Transformers
  - Power electronics operating equipment
  
- II) Advantages of power factor improvement
  - Technical evaluation
  - Economical evaluation
  
- III) Methods of power factor correction
  
- IV) Installation of power factor capacitors
  - Global compensation
  - Individual compensation
  
- V) Determination of the optimum level of compensation
  - Avoidance of tariff penalties

- Reduction of max KVAR

VI) Correction of power factor at:

- Transformer terminals

- Motor terminals

- 

I) Examples of power factor correction before and after installation

II) Harmonic filtering analysis and its effects on the capacitor rating

III) Capacitor banks implementation

## **E21-Batteries Running, Safety & Maintenance of Battery Systems**

### **Objectives:**

To enhance the knowledge and skills of the maintenance & operation supervisors and technicians in dealing with the direct current equipment and Batteries.

### **Who should attend?**

The course is designated for maintenance & operation supervisors and technicians.

### **Duration:**

5 Days (15 hrs)

### **Course outline:**

- Batteries Types & Uses;
- Different Constructions of Nickel Cadmium & Lead Acid Batteries;
- How to Select Correct Battery for each Application;
- Installation Procedures & Considerations;
- Operation of Batteries;
- Maintenance of Batteries;
  
- Condition monitoring and remaining Life time assessment
- Testing of Capacity;
- Safety Procedures.

## E22-Power Quality Problems & Troubleshooting

### Objectives:

To enhance the knowledge and skills of the maintenance & operation supervisors and technicians in dealing with the power sources and increase their quality

### Who should attend?

The course is designated for maintenance & operation supervisors and technicians.

### Duration:

5 Days (15 hrs)

### Course outline:

- Introduction to Power Quality
  - Power Quality Disturbances
  - Power Quality Standards
- Sag & Swell
  - Fault Caused Sags & Swells
  - Motor Starting Sags
  - Calculation Methods
  - Mitigation of Sag & Swell Disturbances
- Harmonics
  - Definition & Indices
  - Harmonic Sources
  - Power System Responses to Harmonics
  - Resonance
  - Harmonic Analysis Methods
  - Mitigation: Filter and Filter Design
  - Mitigation: Other Methods
- Transients
  - Capacitor-Switching Transients and Lightning Transients
  - Circuit Analysis of Cap-Switching Transients

- Mitigation of Transients
- Custom Power
  - Basic Components and Configurations
  - Static Circuit Breaker
  - Static Shunt and Series Compensator
  - Active Harmonic Filter

## **E23-Lightning & Surge Protection**

### **Objectives:**

To enhance the knowledge and skills of the maintenance & operation supervisors and technicians in dealing with the *Lightning & Surge*.

### **Who should attend?**

The course is designated for maintenance & operation supervisors and technicians.

### **Duration:**

5 Days (15 hrs)

### **Course outline:**

- Insulation Strength Characteristics;
- Switching Overvoltage;
- Lightning Overvoltage;
- Lightning Calculations;
- Shielding;
- Contamination;
- Insulation Design;
- Line Performance;
- Arrester Application;
- Compaction;
- Design of Lightning Protection System.

## E24-Reading Electrical Drawings & Schematics

### Objectives:

To enhance the knowledge and skills of the Non-Electrical Engineers & Technicians in dealing with the *Electrical Drawings & Schematics*

### Who should attend?

The course is designated For Non-Electrical Engineers & Technicians

### Duration:

5 Days (15 hrs)

### Course outline:

- ***Introduction to Electrical Drawings***
  - Types of Prints
  - Symbols and Abbreviations
  - Device Numbers
  - Title Block Information
- ***Reading Simple Schematics***
  - Connecting Symbols (Variations)
  - Current Flow
  - Relays and Contacts
  - Proper Approach to Reading
- ***Reading Complex Schematics***
- ***Examples of Real Drawings & Schematics.***

## **E25-ELECTRICAL ENGINEERING** **BASICS(TECHNICAL MANAGERS)**

### **Objectives:**

This course is a basic introduction to basic electrical theory and components. Attendees will gain a familiarity with electrical equipment system operation, and its application in the oil and gas industry. The program will be extremely helpful to individuals who require an awareness of electrical principles and equipment to better communicate with the electrical engineers doing the work.

### **Who should attend?**

The course is designated For Non-Electrical Engineers & Technicians

### **Duration:**

5 Days (15 hrs)

### **YOU WILL LEARN**

- Basic electrical fundamentals as applied to oil & gas facilities
- Fundamentals of how electrical systems work
- Basic principles of switchgear and control devices
- Basic principles of protective relaying and circuit protection
- Basic principles of transformers, motors, and generator systems
- Basic principles of low voltage and high voltage equipment
- Application of various types of power systems
- Basic principles of electrical safety

### **COURSE CONTENT**

- Basics of electricity, electrical control, electrical symbols & schematics
- Transformers, AC motors, DC motors, variable speed/frequency drives, electrical distribution
- Low voltage systems, high voltage systems, UPS power (batteries, chargers, invertors, & emergency generators), lighting systems



- Electrical safety, grounding & bonding, circuit protection & protective relaying
- Generation of power, area classifications, NEMA & IP enclosure ratings, equipment temperature classification

## **E26-ELECTRICAL ENGINEERING FUNDAMENTAL**

### **Objectives:**

This course is a comprehensive introduction to basic electrical theory and components. Attendees will gain a familiarity with electrical equipment system operation, and its application in the oil and gas industry. The program will be extremely helpful to individuals who require some knowledge of electrical principles and equipment to better perform their primary responsibilities and coordinate

### **Who should attend?**

The course is designated For Electrical Engineers & Technicians

### **Duration:**

5 Days (15 hrs)

### **YOU WILL LEARN**

- Basic electrical fundamentals as applied to oil & gas facilities
- Fundamentals of how electrical systems work
- Basic principles of switchgear and control devices
- Basic principles of protective relaying and circuit protection
- Basic principles of transformers, motors, and generator systems
- Basic principles of low voltage and high voltage equipment
- Application of various types of power systems
- Basic principles of electrical safety
- Relevant industry codes, standards, documents, and guidelines

## COURSE CONTENT

- Basics of electricity, electrical control, electrical symbols & schematics
- Transformers, AC motors, DC motors, variable speed/frequency drives, electrical distribution
- Low voltage systems, high voltage systems, UPS power (batteries, chargers, invertors, & emergency generators), lighting systems
- Electrical safety, grounding & bonding, circuit protection & protective relaying
- Generation of power, area classifications, NEMA & IP enclosure ratings, equipment temperature classification, industry regulations, codes, guidelines and standards

## **E27-ELECTRICAL POWER**

### **SYSTEMSFORELECTRICAL TECHNICIANS**

#### **Objectives:**

To enhance the knowledge and skills of the Electrical Technicians in dealing with the Electrical equipments, power generation, control and measurements, power transmission and distribution.in oil and gas fields

#### **Who should attend?**

The course is designated For Electrical Technicians

#### **Duration:**

5 Days (15 hrs)

#### **Course outline:**

CHAPTER 1. Power Generation

CHAPTER 2. Three Phase Connections

CHAPTER 3. Control and Measurement of Electrical Power

CHAPTER 4. Power Transmission and Distribution

CHAPTER 5. Cables

CHAPTER 6. Switchgear

CHAPTER 7. Motors

CHAPTER 8. Rectifying devices

CHAPTER 9. Safety Precautions

## **HV-Heavy Equipment Courses:**

HV01- Applied Failure Analysis

HV02-Diesel Generator Basics

HV03-Diesel Generator Malfunction and trouble shooting

HV04-Heavy Equipment Power Train Fundamentals

## **HV-01 Applied Failure Analysis**

### **Introduction:**

This course is designed to determine the root cause and nature of iron failure elements, it's better to find out the root cause of the failure of any mechanical part before repair or replace.

At the end of this course the trainee will be able to distinguish between the results and the cause of particular failure.

And also can take critical decision concerning failures

### **Who Should Attend?**

Q.C engineers & Supervisors and Mechanical technicians

### **Course Duration:**

5 Days

25 Hours

### **Course Objectives:**

At the end of this course the trainees should be able to :

- 1- Identify several materials and processing
- 2- Parts including inclusions, casting shrinkage, forging laps, quench cracks.
- 3- Analysis determinations and reports
- 4- Fractures and explain the root cause of each type of fracture
- 5- Provide accurate and complete failure analysis report
- 6- Straightening cracks
- 7- Operation and preventative maintenance analysis
- 8- Advice to customer and apply knowledge learned to improving service repair and efficiency practice and overall service quality

### **Major Topics:**

Module 1 – Proper failure analysis management

Module 2 – Study of metallurgy

Module 3 – Principles of wear

Module 4 – Principles of fractures

Module 5 – Visual examination

Module 6 – Threaded fasteners

### **Course Outlines:**

**During this course the topics covered will be applied on defected Engine parts**

- Connecting rods
- Engine bearings
- Crankshafts
- Piston rings and liners
- Engine valves
- Engine cylinder head
- Turbochargers
- Lubricant analysis (will be discussed during all modules)

### **Notes :**

- 1- Pre & post test will be conducted
- 2- Training will be applied on defected engine parts

# **HV-02 Diesel Generators, Design, Ratings, Sizing, Applications, Control, Protection and Auxiliary Systems**

## **Introduction:**

This course is designed to explain the urgent demand for standby and prime power diesel generators in power plants. It also help in sizing the suitable generator for certain load types and for certain load profiles and when it comes to interpreting specifications and how customize the diesel generators and make it comply and meet these specifications.

This course discusses diesel generator design and applications in addition to diesel generators ratings, sizing for site load, auxiliary systems, instruments, controls, protection, testing, vibration, sound level and installation.

## **Who Should Attend?**

Application ,Service engineers & Supervisors, Mechanical & Electrical technicians

## **Course Duration:**

6 Days

30 Hours

## **Major Topics:**

**Module 1 – Diesel Engine Structure**

**Module 2 – Power generation concept**

**Module 3 – Diesel generator sizing and calculations**

**Module 4 – Diesel generator control system design**

**Module 5 – Diesel Generator Protection**

**Module 6 – Diesel generator maintenance procedure**

## **Course Outlines:**



## **Module 1 – Diesel Engine Structure**

- Main components illustrations
- Engine Lube oil system
- Engine Fuel System
- Speed governor
- Engine cooling System
- Diesel generator fluids
- Compressed air starting system

## **Module 2 – Power generation concept**

- AC generator construction
- Brushless excitation system
- AC generator specifications and rating
- Lead acid batteries specifications and sizing calculations

## **Module 3 – Diesel generator sizing and calculations**

- Diesel generator planning and specifications
- Skid base design and equipment mounting
- Muffler grade selection and sizing
- Exhaust system piping sizing and calculations
- Acoustic enclosure design
- Diesel generator vibration concept, parameter, measurements, analysis and control.

## **Module 4 – Diesel generator control system design**

- Engine sensing and indicating instruments
- Jacket water and Lube oil heaters criteria and sizing
- Engine electronic management system
- Switch gear and distribution

## **Module 5 – Diesel Generator Protection**

- Diesel generator parallel operation
- Testing equipment and instruments
- Diesel generator testing procedure

## **Module 6 – Diesel generator maintenance procedure**

- Generator installation consideration
- Applicable international standard

## **HV03-Diesel Generators Malfunction and Trouble Shooting**

### **Introduction:**

This course is designed to state the logical sequence to be followed to trouble shoot diesel generators malfunctions. It also helps to analysis and determines the root cause of the problem to be avoided.

### **Who Should Attend?**

Service engineers & Supervisors, Mechanical & Electrical technicians

### **Course Duration:**

6 Days

30 Hours

### **Major Topics:**

**Trouble shooting sequence for the following malfunction:**

- 1- Engine not being started**
- 2- Deficient power of diesel engine**
- 3- Engine stopping automatically**
- 4- Exhaust with black smoke**
- 5- Exhaust with blue smoke**
- 6- Exhaust with white smoke**
- 7- Checking methods when the engine encounters malfunction**
- 8- Generator not being started**
- 9- Generator not generating electricity**
- 10- Damage cause and remedy of brushless alternator**
- 11- Damage cause and remedy of brush alternator**
- 12- Inspections before operation and maintenance**

### **Notes :**

Pre &post test will be conducted



Module 3 – List of the different types of transmissions used in Heavy Equipment

Module 4 – Distinguish between the different disc clutches and plates types

Module 5 – Description of the function and operation for transmission hydraulic

Module 6 – Operation and function of final drive and differential

Module 7 – Final drive diagnosis and maintenance

### **Course Outlines:**

- Hydro Dynamic Drives
- Planetary gear sets & torque divider
- Countershaft type power shift transmission
- Planetary type power shift transmission
- Manual controlled power shift transmission control valve
- Differential
- Final drive

### **Notes :**

Pre &post test will be conducted

## **AU-Automotive Courses:**

AU01- Advanced injection systems in Gasoline & Diesel Engines

AU02-Air brake system maintenance in Heavy Trucks

AU03-Automatic gear boxes in modern vehicles

AU04-Defensive Driving Safety Training

AU05-Modern Vehicles Safety & Comfort Features Technologies

AU06-Vehicle Systems Mechanisms Introduction

## **AU-01 Advanced injection systems in Gasoline & Diesel Vehicles**

### **Introduction:**

Modern vehicles had been developed and achieved great progress in Fuel Injection system. This course covers both injection system in Gasoline & Diesel engines like Moronic system, Common rail diesel injection (HDI). Vehicle sensors and actuators are covered in details in addition to diagnosis system. By the end of this course trainee will be able to understand modern gasoline & diesel injection system components beside diagnosis system and troubleshooting.

### **Who Should Attend?**

Automotive Service engineers & Supervisors and Mechanical technicians

### **Course Duration:**

6 Days

30 Hours

### **Major Topics:**

Module 1- Electronic gasoline fuel injection outline

Module 2 – Static ignition and electronic spark advance system

Module 3 – System diagnosis and troubleshooting

Module 4 – Common rail diesel injection system

Module 5 – Air intake system & Turbo charging circuit

Module 6 – Special features of HDI system functioning principles.

### **Course Outlines:**

#### **Module 1 – Electronic fuel injection outline**

- Function - theory
- Sensors function- theory
- Actuators
- Maintenance

## **Module 2 – Static ignition and electronic spark advance system**

- System components
- Idle speed control system ISC
- Variable valve timing intelligent VVTI
- Electronic control unit function
- Electrical system wiring diagram

## **Module 3 –System diagnosis and troubleshooting**

- Fault diagnosis system
- Knowledge of emission control standard Euro 3

## **Module 4 – Common rail diesel injection system HDI**

- Function - theory
- Sensors operation
- Actuators
- High pressure pump
- Injectors specifications
- Maintenance

## **Module 5 – Air intake & Turbo charging circuit**

- Inlet air heating management.
- Flame start device
- Variable swirl system

## **Module 6 – Special features of HDI system functioning principle**

- Engine management control function
- System diagnosis and troubleshooting

Notes:

- 1- Pre test&post test will be conducted.
- 2- Multimedia training aids will be used.
- 3- Parts demonstration will be done on disassembled parts.





- Compressor and Governor
- Reservoirs
- Air dryer
- Safety valve
- Foot valve
- Brake chambers & slack adjusters

### **Module 3 –Operation of air brake system**

- Basic air brake system control valves
- One way check valve
- Automatic front brake limiting valve
- Quick release valve
- Relay valve
- Manual front brake limiting valve & load sensing valve

### **Module 4 – Parking brake and dual air brake system**

- Dual air brake system operation and tracing
- Spring parking brake with modulator valve

### **Module 5 – ABS in Heavy trucks and Buses**

- ABS system function
- System different components
- ABS electronic system control

### **Module 6 – System service checkup, brake adjustment and fault diagnosis**

- Practical session including the following :
  - 1- S-cam brake adjustment with manual slack adjuster
  - 2- Air brake system on truck operating pressure checking
  - 3- Drum brake components disassembly
  - 4- Adjustment of brake shoes clearance
  - 5- Maintenance and servicing of air brake system

## **AU03-Automatic Gear Boxes in Modern Vehicles**

### **Introduction:**

Modern vehicles equipped with top range of automatic transmissions with highly advanced electronic control features.

This course covers different automatic gearboxes series fitted with top range vehicles like steptronic auto adaptive transmission. MMT transmission in addition to AM6 automatic transmission

Trainee will be able to understand operation of torque converter, sensor managed gear selection in addition to hydraulic operation of shift mechanism.

Trainee will be familiar with operating precautions to enhance transmission performance, also will be aware about fault warning signals and fault symptoms to be avoided

### **Who Should Attend?**

Automotive Service engineers & Supervisors and Mechanical technicians

### **Course Duration:**

6 Days

30 Hours

### **Major Topics:**

Module 1 – Types of automatic transmissions fitted in top range vehicles

Module 2 – Torque converter principle of operation

Module 3 – Planetary gear set

Module 4 – Hydraulic circuit operation

Module 5 – Transmission control unit inputs & outputs

Module 6 – Transmission maintenance & Troubleshooting

### **Course Outlines:**

**Module 1 – Types of automatic gear boxes fitted in modern vehicles**

- Auto adaptive transmission (AL4)
- Step tronic transmission ( 4 HP20 )
- AM6 transmission ( 6 forward speeds )
- Operating principle
- Gear lever position

### **Module 2 – Torque converter**

- Operating principle.
- Components
- Lock up clutch function - types
- Vibration damper

### **Module 3 –Planetary gear set**

- Simple epicyclical Drive
- Gear train components
- Clutch set function - operation
- Brake band function
- Activation sequence of planetary gear at each speed

### **Module 4 – The hydraulic circuit**

- Body valve solenoids
- Hydraulic circuit tracing while engage D position
- Hydraulic circuit tracing while engage R position
- Hydraulic circuit tracing while engage 1 position
- Hydraulic circuit tracing while engage 2 position
- Hydraulic circuit tracing while engage 3 position

### **Module 5 – Transmission control unit inputs & output signals**

- Transmission electrical elements
- Control unit
- Transmission operating programs

## **Module 6 – Transmission Maintenance & operating precautions**

- Transmission fluid
- System diagnosis
- Instrument panel warning signals

Notes:

- 1- Pre &post test will be conducted
- 2- Multimedia training aids will be used



## Major Topics:

**Module 1 – Defensive drive definition introduction**

**Module 2 – Accidents and general cause of accidents**

**Module 3 – Defensive driving skills**

**Module 4 – Vehicle maintenance and pre-trip inspection**

**Module 5 – Practical assessment on simulator**

## Course Outlines:

**Module 1 – Defensive drive definition introduction**

- Defensive drive definition
- Driver attitude
- Drivers classification
- Defensive / offensive
- Defensive driving standards

**Module 2 – Accidents and general cause of accidents**

- Cause of accidents, and description
- Preventable accidents
- Common driving errors
- Excuses we give for accidents
- Following distance rule
- Accident drowsiness due to medication (real case study)
- Accident following too closely (real case study)

**Module 3 – Defensive driving skills**

- Accident prevention, and driving behaviors
- While using and changing lanes
- Passing
- Negotiation curves
- Negotiation down grades
- Parking
- Pedestrian interaction

## **Module 4 – Vehicle maintenance and pre-trip inspection**

## **Module 5 – Practical assessment on simulator**

### **Notes :**

- 1- Pre and post test will be conducted
- 2- Training will be conducted on your premises or in Protech training center facilities
- 3- Training will be conducted in Arabic
- 4- Printed evaluation assessment sheet will be delivered



## **AU05-Modern Vehicles Safety & Comfort Features Technologies**

### **Introduction:**

Vehicles have strong progress in modern system by using advanced technologies. This course covers modern vehicle safety & comfort features which available at top range series. All features will be illustrated in details explaining function usage and familiarization with systems faults warning signals.

By end of this course trainee will be able to understand modern vehicle features importance in addition to be familiar with system features and diagnosis.

### **Who Should Attend?**

Automotive Service engineers, Supervisors and Electrical technicians

### **Course Duration:**

6 Days

30 Hours

### **Major Topics:**

**Module 1 – Introduction to multiplexing network**

**Module 2 – Airbag system and pre-tensioner seat belt mechanism**

**Module 3 – ABS system & Electronic Stability Control System (ESP)**

**Module 4 – Engine immobilizer system**

**Module 5 – Automatic wind screen wiper system**

**Module 6 – Electronic suspension control**

**Module 7 – Electronic exterior lighting**

**Module 8 – Electronic power assisted steering (GEP system)**

### **Course Outlines:**

## **Module 1 – Introduction to multiplexing network**

- Principle of multiplexing network
- VAN network
- CAN network
- Full CAN architecture
- Supply power management

## **Module 2 – Airbag system and pre-tensioner seat belt mechanism**

- Different components of Airbag system
- Precautions should be followed when deal with Airbag system
- System diagnosis and trouble shooting

## **Module 3 – ABS system & Electronic Stability Control System (ESP)**

- ABS system function
- System components
- Wheel sensors
- ABS regulation unit
- System diagnosis
- Electronic Stability control system (ESP)
- How ( ESP) works

## **Module 4 – Engine immobilizer system**

- Immobilizer system components and function
- How does a immobilizer system work
- Key programming procedure

## **Module 5 – Automatic wind screen wiper system**

- Automatic wind screen wiper system description and operation
- Rain sensor

## **Module 6 – Electronic suspension control**

- System function
- System sensors
- System initialization procedure

- Actuators
- System diagnosis

### **Module 7 – Electronic exterior lighting**

- System components - Function
- Discharge pulp system (XENON)
- System actuators
- Front head light height adjustment system

### **Module 8 – Electronic power assisted steering (GEP system)**

- System definition
  - 1- Conventional steering column
  - 2- An electro pump assembly
  - 3- Connecting pipes
  - 4- Rake with assistance valve
  - 5- System principal of operation
  - 6- System diagnosis

Note:

- 1- Pre &post test will be conducted
- 2- Multimedia training aids will be used



- Gasoline engine ( basic four stroke theory and definition )
- Lubrication system components
- Cooling system components and Function
- Gasoline Fuel system components – Carburetor function and circuits
- Difference between diesel engine and Gasoline engine

### **Module 3 –Drive train components**

- Outline of drive train types
- Clutch , types and operating mechanism
- Manual transmission types and shift control mechanism
- Automatic transmission components
- Torque convertor function and operation
- Planetary gears sets and clutch set
- Body valve control

### **Module 4 – Chassis system components**

- Brake system types and components ( disc drum and brake drum )
- Difference between diagonal piping and conventional piping
- Brake system inspection
- Suspension and steering system components and function
- Power steering system inspection and checking
- Wheel alignment procedure and tire balancing

### **Module 5 – Fundamentals of Electricity and body electrical system**

- Basic electrical wiring diagram tracing and symbols
- Battery inspections and checking
- Starter motor and alternator
- Body electrical system components
- Lighting bulbs checking
- Instrument panel warning signals

### **Module 6 – Vehicle periodic maintenance schedule**

- Pre-delivery inspection
- Pre and post vehicle repair inspection sheet
- Efficient Maintenance Service (EMS)

**Notes :**

- 5- Pre and post test will be conducted
- 6- Practical will be demonstrated on disassembled parts and vehicles.

## **IN-Inspection Courses:**

API510-Pressure Vessels Inspector Preparation Course API-510

API570-Piping Inspector preparation Course API-570

API571-Damage mechanisms

API577-Welding Inspection & Metallurgy

API580-Risk Based Inspection

API653-Tank Inspector Preparation Course API-653

C1-ASME B31.3 Process piping

C2-AWS D1.1 Code; Structural Steel Welding Code

C3-ASME31.1 Power & Process Piping

C4-ASME Section IX (Welding & Brazing WPS, PQR, WPQ)

C5-Boilers & Pressure Vessels ASME VIII (Design, Fabrication and Inspection)

C6-Overview of API (Knowledge- API1104 for Pipelines-API650,653 for Storage Tanks – API510 for Pressure Vessel Inspection)

C7-General Mechanical Codes and Standard and Specification Course

C8-ASME Code Section Nondestructive Testing (NDT)

MM39-AWS D1.1 Code; Structural Steel Welding Code

NDT01-Radiographic Testing (RT) Level I & II

NDT02-Ultrasonic Testing (UT) Level I & II

NDT03-Magnetic Particle Testing (MT) level I & II

NDT04-Dye Penetrate Testing (PT) level I & II

NDT05-Visual Inspection (VT) level I & II

NDT06-Eddy Current Testing (ET) Level I & II

NDT07-Inspection & NDT Fundamentals

PL01-Piping Design (Specification & Sizing)

PL02-Pipeline Construction

PL06-Pipeline Inspection, Maintenance, Repair

PL07-Pigging and Smart Pigging

W01-Certified Welding Inspector (CWI); Preparation Course

W02-CSWIP 3.1 Preparation Course

W03-CSWIP 3.2.2 Preparation Course

W04-Welding Technology for Basic Welding Process

W05-WPS, PQR, WPQ Overview & Preparation and Electrodes Selection

W06-Welding Metallurgy and Heat Treatment

W07-Material Testing Evaluations

W08-Material Selection, Receiving and Review of Mill Test Certificates



# **IN01-API510-Pressure Vessels Inspector Preparation**

## **Course**

### **API-510**

#### **Introduction:**

- ▶ To know the design criteria for a vessel
- ▶ To learn how to size the vessel and specify the proper material
- ▶ To learn how to create the specification
- ▶ To learn how to use the Pressure Vessel Code

#### **Who Should Attend?**

- ▶ New mechanical, production and design engineers.
- ▶ Senior engineers, section heads, process engineers and department heads.

#### **Course Duration:**

5 Days

#### **Course Outlines:**

- ▶ Pressure vessel types, basic components and applications
- ▶ List codes, design standards and specifications
- ▶ Design Considerations
- ▶ Design Element Procedures
- ▶ Purchasing, Testing and Certification
- ▶ Heat Exchangers

## IN02-API570-Piping Inspector preparation Course API-570

### Introduction:

- ▶ To understand API 570 code and how to use.
- ▶ To know the design criteria for a piping
- ▶ To learn how to size the piping and specify the proper material
- ▶ To learn how to create the specification
- ▶ To learn how to use the piping Code

### Who Should Attend?

Experienced Engineers in welding activities and different codes covering these activities

### Course Duration:

5 Days

### Course Outlines:

- ▶ ASME B31.3 scope and limitations
- ▶ piping materials and its properties
- ▶ Prequalified WPS
- ▶ Roles of piping fabrications
- ▶ process piping inspections and its procedures
- ▶ Repair procedures of steel piping defects
- ▶ ASME IX, V, B16.5 & API 574, API 577, API 571

## IN03-API571-Damage mechanisms

### Introduction:

- ▶ To know the damage mechanisms in oil & Gas industry
- ▶ How to inspect different damage mechanisms.
- ▶ How to prevent main damage mechanisms.
- ▶ Suspected Equipment.

### Who Should Attend?

- ▶ New mechanical, production and design engineers.
- ▶ Senior engineers, section heads, process engineers and department heads.

### Course Duration:

5 Days

### Course Outlines:

- ▶ Fundamentals of corrosion
- ▶ How to prevent corrosion
- ▶ Different corrosion types.
- ▶ Suspected equipment in oil & Gas

## **IN04-API577-Welding Inspection & Metallurgy**

### **Introduction:**

- ▶ To understand the scope of API 577 code and how to use.
- ▶ To identify the difference between codes, standards and specifications.
- ▶ To know the tools for welding inspection.

### **Who Should Attend?**

Engineers & Technicians

### **Course Duration:**

5 Days

### **Course Outlines:**

- ▶ API 577 scope and limitations
- ▶ materials and its properties
- ▶ Prequalified WPS
- ▶ Welding processes
- ▶ Welding inspection and its procedure
- ▶ Repair procedures of in-service components
- ▶ Electrode selection

## **IN05-API580-Risk Based Inspection**

### **Introduction:**

- ▶ To understand the scope of API 580 code and how to use.
- ▶ Risk Based Inspection Methodology.

### **Who Should Attend?**

Experienced Engineers in welding activities and different codes covering these activities

### **Course Duration:**

5 Days

### **Course Outlines:**

- ▶ API 580 & API 581
- ▶ Rules of API 580
- ▶ Probability of failure.
- ▶ Consequence of failure.
- ▶ Risk calculation

## **IN06-API653-Tank Inspector Preparation Course API-653**

### **Introduction:**

- ▶ To know the design criteria for a tank
- ▶ To learn how to size the tank and specify the proper material
- ▶ To learn how to create the specification
- ▶ To learn how to use the tank Code

### **Who Should Attend?**

- ▶ New mechanical, production and design engineers.
- ▶ Senior engineers, section heads, process engineers and department heads..

### **Course Duration:**

5 Days

### **Course Outlines:**

- ▶ tank types, basic components and applications
- ▶ List codes, design standards and specifications
- ▶ Design Considerations
- ▶ Design Element Procedures
- ▶ Purchasing, Testing and Certification
- ▶ Above ground tank inspection practices.

## IN07-C1-ASME B31.3 Process piping

### Introduction:

- ▶ To know the design criteria for process piping
- ▶ To learn how to size the piping and specify the proper material
- ▶ To learn how to create the specification
- ▶ To learn how to use the process piping Code

### Who Should Attend?

- ▶ New mechanical, production and design engineers.
- ▶ Senior engineers, section heads, process engineers and department heads.

### Course Duration:

5 Days

### Course Outlines:

- ▶ piping basic components and applications
- ▶ List codes, design standards and specifications
- ▶ Design Considerations
- ▶ Design Element Procedures
- ▶ Purchasing, Testing and Certification
- ▶ Acceptance criteria for piping fabrication

## IN08-C2-AWS D1.1 Code; Structural Steel Welding Code

### Introduction:

- ▶ To understand the scope of AWS D1.1 code and how to use.
- ▶ To identify the difference between codes, standards and specifications.
- ▶ To know acceptance criteria of steel structures in several forms.

### Who Should Attend?

Experienced Engineers in welding activities and different codes covering these activities.

### Course Duration:

5 Days

### Course Outlines:

- ▶ AWS D1.1 scope and limitations
- ▶ Steel structure materials and its properties
- ▶ Prequalified WPS
- ▶ Roles of steel structure fabrications
- ▶ Steel structures inspections and its procedures
- ▶ Repair procedures of steel structures defects
- ▶ AWS D1.1 annexes



## **IN09-C3-ASME31.1 Power & Process Piping**

### **Introduction:**

- ▶ To be able to choose the suitable codes used in power piping.
- ▶ To understand the design and materials needed in power piping system.
- ▶ To understand the inspection procedure and acceptance criteria in power piping.

### **Who Should Attend?**

- ▶ Engineers & Technicians with good English

### **Course Duration:**

5 Days

### **Course Outlines:**

- ▶ Scope and Definitions
- ▶ Design (condition and criteria)
- ▶ Pressure design of piping
- ▶ Materials
- ▶ Fabrication assembly and erection
- ▶ Inspections, examination and testing

## **IN010-C4-ASME Section IX (Welding & Brazing WPS,PQR,WPO)**

### **Introduction:**

- ▶ To understand WPS &PQR and know how to evaluate its essential and non essential variables
- ▶To understand the rules governing qualify WPS and welder qualification procedures
- ▶To be able to prepare WQT and WPS to different cases

### **Who Should Attend?**

- ▶ Engineers & Technicians with good English

### **Course Duration:**

5 Days

### **Course Outlines:**

- ▶ Essential and non essential variables for Different welding methods
- ▶ Welder qualifications test (WQT)
- ▶ Preparation Procedure Qualifications Recommend (PQR)
- ▶ Preparations of Welding procedure Specifications (WPS)

## **IN011-C5-Boilers & Pressure Vessels ASME VIII (Design, Fabrication and Inspection)**

### **Introduction:**

- ▶ To understand the scope of ASME VIII code and know how to use
- ▶ To identify general requirements and rules of construction of pressure vessels
- ▶ To understand rules of inspection of pressure vessels

### **Who Should Attend?**

Experienced Engineers in pressure vessels industries and codes.

### **Course Duration:**

5 Days

### **Course Outlines:**

- ▶ Scope of ASME VIII and limitations
- ▶ Materials used in pressure vessels constructions and their properties
- ▶ Pressure vessels fabrication
- ▶ Pressure vessels inspection and testing
- ▶ Pressure vessels marking and reporting
- ▶ Pressure relief device

## **IN012-C6-Overview of API (Knowledge- API1104 for Pipelines-API650,653 for Storage Tanks – API510 for Pressure Vessel Inspection)**

### **Introduction:**

- ▶ To understand the scope of API 1104 ,650,653 and 510 and standards related to its requirements.
- ▶ To understand construction requirements related to API specs.
- ▶ To understand inspection requirements for tanks , pipe lines and pressure vessels and when the repair, alteration or rerating becomes essential
- ▶ To learn how to establish inspection frequencies plan according to API specs.

### **Who Should Attend?**

- ▶ Piping engineers
- ▶ Welding inspectors and engineers
- ▶ NDT operators, inspectors and engineers

### **Course Duration:**

5 Days

### **Course Outlines:**

- ▶ Introduction the scope of API 1104,650,653 and 510
- ▶ Duties and responsibility
- ▶ Constructions requirements in deferent applications
- ▶ Materials needed in tanks ,pipe lines and pressure vessels
- ▶ Inspection and testing practices
- ▶ Frequency and extent of inspection

- ▶ Inspection data evaluation and analysis
- ▶ Repairs cases and inspection checklist

## **IN013-C7-General Mechanical Codes and Standard and Specification Course**

### **Introduction:**

- ▶To be familiar with several codes and the scope of each one.
- ▶To be able to show the difference between code, standard and specification and when we use each one.

### **Who Should Attend?**

Engineers & Technicians with good English

### **Course Duration:**

5 Days

### **Course Outlines:**

Complete explanation for the following codes & standards and their application in welding, qualification and certification:

- ▶API 1104.
- ▶AWS D1.1.
- ▶ASME IX.

## **IN014-C8-ASME Code Section V;Nondestructive Testing (NDT)**

### **Introduction:**

- ▶ To understand the different NDT methods and its applications.
- ▶ To learn how to evaluate all essential and non essential variables in different test methods.

### **Who Should Attend?**

- ▶ Welding and Inspection Engineers and Technicians with good English.

### **Course Duration:**

5 Days

### **Course Outlines:**

- ▶ NDT Methods (UT,RT,PT,MT)
- ▶ Essential and non essential variables in test methods
- ▶ Reporting requirements in NDT methods
- ▶ Acceptance criteria for each NDT method

## **IN015-MM39-AWS D1.1 Code; Structural Steel Welding Code**

### **Introduction:**

- ▶ To understand the scope of AWS D1.1 code and how to use.
- ▶ To identify the difference between codes, standards and specifications.
- ▶ To know acceptance criteria of steel structures in several forms.

### **Who Should Attend?**

Experienced Engineers in welding activities and different codes covering these activities.

### **Course Duration:**

5 Days

### **Course Outlines:**

- ▶ AWS D1.1 scope and limitations
- ▶ Steel structure materials and its properties
- ▶ Prequalified WPS
- ▶ Roles of steel structure fabrications
- ▶ Steel structures inspections and its procedures
- ▶ Repair procedures of steel structures defects
- ▶ AWD D1.1 annexes



## **IN016-NDT01-Radiographic Testing (RT) Level I & II**

### **Introduction:**

Qualification of Personnel in Radiographic Test Method –RT According to American Society of Non Destructive Testing (ASNT) .

### **Who Should Attend?**

- ▶ Engineers and technicians who are responsible for inspection fabrication and quality control in petroleum sector.
- ▶ Welding engineers and technicians who work in plants or fields

### **Course Duration:**

5 Days

### **Course Outlines:**

- ▶ NDT Training and Certification
- ▶ Introduction to Radiographic Testing
- ▶ Energy, Intensity and Absorption
- ▶ Generation of X-Rays
- ▶ Gamma Ray Sources
- ▶ Subject and Film Contrast
- ▶ Radiographic Films
- ▶ Permissible Radiation Dose
- ▶ Radiation Effects and Detection

- ▶ Specialized Radiographic Equipment
- ▶ Exposure and Equivalence Charts
- ▶ Radiographic Techniques
- ▶ Specialized Radiographic Techniques
- ▶ Materials Discontinuities
- ▶ Welding Discontinuities
- ▶ Specific Code, Interpretation
- ▶ X-ray exposure charts
- ▶ Radioisotope exposure charts
- ▶ Film interpretation
- ▶ Evaluation according to code
- ▶ ASME V article 2

## IN017-NDT02-Ultrasonic Testing (UT) Level I & II

### Introduction:

Qualification of Personnel in Radiographic Test Method –UT According to American Society of Non Destructive Testing (ASNT).

### Who Should Attend?

- ▶ Engineers and technicians who are responsible for inspection fabrication and quality control in petroleum sector.
- ▶ Welding engineers and technicians who work in plants or fields

### Course Duration:

5 Days

### Course Outlines:

- ▶ NDT Training and Certification
- ▶ Introduction to Ultrasonic Testing
- ▶ Ultrasonic Principles
- ▶ Equipment
- ▶ Basic Ultrasonic Testing Methods
- ▶ Wave Propagation
- ▶ Couplants, Material Characteristics
- ▶ Displaying Ultrasonic Indications
- ▶ Transducer Operation and Theory
- ▶ Standard Reference Blocks
- ▶ Immersion Test
- ▶ Contact Test

- ▶ Non Relevant Indications
- ▶ Materials Discontinuities
- ▶ Welding Discontinuities
- ▶ Practical / Application of Contact Testing

#### Discontinuity types

- ▶ Non relevant ultrasonic indications
- ▶ Lamination test
- ▶ Interpretation of UT indications
- ▶ Evaluation according to code
- ▶ ASME V article 4

## **IN018-NDT03-Magnetic Particle Testing (MT) level I & II**

### **Introduction:**

Qualification of Personnel in Radiographic Test Method –MT According to American Society of Non Destructive Testing (ASNT) .

### **Who Should Attend?**

- ▶ Engineers and technicians who are responsible for inspection fabrication and quality control in petroleum sector.
- ▶ Welding engineers and technicians who work in plants or fields

### **Course Duration:**

5 Days

### **Course Outlines:**

- ▶ NDT Training and Certification
- ▶ Magnetic Particle Test Principles
- ▶ Circular Magnetization
- ▶ Longitudinal Magnetization
- ▶ Hysteresis Loop
- ▶ Residual Magnetism
- ▶ Demagnetization
- ▶ Equipment
- ▶ Magnetic Particle Mediums
- ▶ Safety Precautions
- ▶ Settling Test
- ▶ Magnetic Particle Applications

- ▶ Surface Preparation
- ▶ Materials Discontinuities
- ▶ Welding Discontinuities
- ▶ Practical / Application of Test

## **IN019-NDT04-Dye Penetrant Testing (PT) level I & II**

### **Introduction:**

Qualification of Personnel in Radiographic Test Method –PT According to American Society of Non Destructive Testing (ASNT) .

### **Who Should Attend?**

- ▶ Engineers and technicians who are responsible for inspection fabrication and quality control in petroleum sector.
- ▶ Welding engineers and technicians who work in plants or fields

### **Course Duration:**

5 Days

### **Course Outlines:**

- ▶ NDT Training and Certification
- ▶ Liquid Penetrant Test Principles
- ▶ Type of dye
- ▶ Type of Removable
- ▶ Equipment
- ▶ Safety Precautions
- ▶ Surface Preparation
- ▶ Penetrant Application
- ▶ Dwell Time
- ▶ No Relevant Indications
- ▶ True Indications
- ▶ Post Cleaning

- ▶ Quality Control of Penetrant Test Materials
- ▶ Materials Discontinuities
- ▶ Welding Discontinuities
- ▶ Practical / Application of Test



## IN020-NDT05-Visual Inspection (VT) level I & II

### Introduction:

Qualification of Personnel in visual test (VT) According to American Society of Non Destructive Testing (ASNT) and American Welding Society (AWS).

### Who Should Attend?

- ▶ New mechanical, production and design engineers.
- ▶ Engineers and Technicians who are responsible for Inspection, Fabrication and Quality Control.

### Course Duration:

5 Days

### Course Outlines:

- ▶ VT Training and Certification
- ▶ Introduction to visual testing requirements
- ▶ Safety requirements in welding and visual inspection
- ▶ Welding process (SMAW,GMAW,FCAW,GTAW and SAW)
- ▶ Materials properties and testing
- ▶ Welding Discontinuities
- ▶ Specific Code, Interpretation

## **IN021-NDT06-Eddy Current Testing (ET) Level I & II**

### **Introduction:**

Qualification of Personnel in Radiographic Test Method –ET According to American Society of Non Destructive Testing (ASNT).

### **Who Should Attend?**

- ▶ New mechanical, production and design engineers.
  
- ▶ Engineers and Technicians who are responsible for Inspection, Fabrication and Quality Control.

### **Course Duration:**

5 Days

### **Course Outlines:**

- ▶ Basic physics of Eddy Current
  
- ▶ interpretation
  
- ▶ Evaluation according to code
  
- ▶ ASME V

## IN022-NDT07-Inspection & NDT Fundamentals

### Introduction:

- ▶ To understand inspection methods and how to evaluate its essential and non-essential variables.
- ▶ To understand the rules governing caring NDT methods and its acceptance criteria..

### Who Should Attend?

- ▶ QC/ QA engineers
- ▶ Welding inspectors
- ▶ Construction engineers

### Course Duration:

5 Days

### Course Outlines:

- ▶ Introduction to inspections types
- ▶ The difference between DT & NDT
- ▶ Types of DT and when it should be essential
- ▶ The difference between examination, inspection and testing
- ▶ Over view about NDT inspection methods (VT,UT,MT,RT,PT)
- ▶ Case studies about how to use this methods on: tanks ,pipeline and piping

## **IN023-PL01-Piping Design (Specification &Sizing)**

### **Introduction:**

- ▶ To have an overview of pipeline industry.
- ▶ To understand the design and construction of both gas and liquid pipeline systems.
- ▶ To gain the essential knowledge and skills to design and construct pipelines.
- ▶ To be able to contribute to cost effective, safe and sound-design of pipelines.

### **Who Should Attend?**

- ▶ Managers, engineers, operators, supervisors, inspectors and equipment suppliers.

### **Course Duration:**

5 Days

### **Course Outlines:**

- ▶ Pipeline Design
- ▶ Design of Gas Pipelines
- ▶ Design of Liquid Pipelines
- ▶ Design of two-Phase Pipelines
- ▶ Construction of P/L
- ▶ Common features of P/L Construction
- ▶ Construction of Land Pipeline.
- ▶ Construction of Offshore Pipeline

## IN024-PL02-Pipeline Construction

### Introduction:

- ▶ To learn how to respond to worksite construction activities in safe manner.
- ▶ To build skills to recognize hazards and learn how to assess and control them.
- ▶ To learn to operate equipment safely.
- ▶ To learn how to respond to emergencies.

### Who Should Attend?

- ▶ Managers, engineers, operators, supervisors, inspectors and equipment suppliers.

### Course Duration:

5 Days

### Course Outlines:

- ▶ Introduction to Construction
- ▶ Welding Overview
- ▶ Construction of P/L
- ▶ Common features of P/L Construction
- ▶ Construction of Land Pipeline
- ▶ Construction of Offshore Pipeline

## **IN025-PL06-Pipeline Inspection, Maintenance, Repair**

### **Introduction:**

To gain the essential knowledge and skills to design, maintain and repair pipelines.

### **Who Should Attend?**

- ▶ Pipeline and piping engineering and design personnel
- ▶ Engineers, designers, operators and draftspersons in the piping field

### **Course Duration:**

5 Days

### **Course Outlines:**

- ▶ Pipeline & Piping Components
- ▶ Piping Materials
- ▶ Pipeline & Piping Codes and Standards
- ▶ Pipeline Maintenance
- ▶ Pipeline Repair

## IN026-PL07-Pigging and Smart Pigging

### Introduction:

▶ To be able to choose the right technology for pipeline cleaning and inspection.

▶ To determine the need for preventive maintenance or pipeline reconditioning.

▶ To determine rates of corrosion and evaluate cathodic protection programs.

▶ To perform an alter-the-fact inspection following a leak or rupture.

▶ To assist in evaluating a pipeline for a proposed pressure, product, or medium change.

▶ To aid in determining the value of a pipeline being considered for acquisition.

▶ To locate pipeline features and non-corrosion defects such as hard spots,

Casing, taps, stopples, etc.

### Who Should Attend?

▶ Managers, engineers, operators, supervisors, inspectors and equipment suppliers.

▶ Other employees who seek to sharpen their understanding towards

mentioned topics

### Course Duration:

5 Days

### Course Outlines:

- ▶ Principles of liquid flow through pipelines.
- ▶ Art of pigging.
- ▶ Range of intelligent in-line inspection tools.
- ▶ Principle and operation of ultrasonic pipeline inspection equipment.
- ▶ Principle and operation of magnetic flux leakage pipeline inspection equipment.
- ▶ Comparison of methods, ultrasonic and magnetic flux leakage.
- ▶ Principle and operation of electronic Geometry tools.
- ▶ Final report interpretation.



## IN027-W01-Certified Welding Inspector (CWI); Preparation Course

### Introduction:

The Certified Welding Inspector (CWI) will be capable of directing those operations associated with weldments and other types of joints that are completed in accordance with the appropriate contract documents, codes, and other standards to produce a satisfactory product.

### Who Should Attend?

All personnel responsible for making decisions , exercising judgment applicable to welding operations in power generation , petrochemical oil and gas fertilizer, ship building and maintenance, structural fabrication, offshore and onshore structural fabrication

### Course Duration:

5 Days

### Course Outlines:

- ▶ Metal joining and cuing processes
- ▶ Standard welding terms and definitions
- ▶ Weld joint geometry and welding symbols
- ▶ Residual stresses and distortion
- ▶ Welding metallurgy
- ▶ Metal properties and destructive testing
- ▶ Nondestructive evaluation methods and symbols
- ▶ Welding safety
- ▶ Weld and base metal discontinuities

## IN028-W02-CSWIP 3.1 Preparation Course

### Introduction:

CSWIP 3.1 Welding Inspector will be capable of directing those operations associated with weldments and other types of joints that are completed in accordance with the appropriate contract documents, codes, and other standards to produce a satisfactory product.

### Who Should Attend?

All personnel responsible for making decisions , exercising judgment applicable to welding operations in power generation , petrochemical oil and gas fertilizer, ship building and maintenance, structural fabrication, offshore and onshore structural fabrication.

### Course Duration:

5 Days

### Course Outlines:

- ▶ Metal joining and cuing processes
- ▶ Standard welding terms and definitions
- ▶ Weld joint geometry and welding symbols
- ▶ Residual stresses and distortion
- ▶ Welding metallurgy
- ▶ Metal properties and destructive testing
- ▶ Nondestructive evaluation methods and symbols
- ▶ Welding safety
- ▶ Weld and base metal discontinuities

## IN029-W03-CSWIP 3.2.2 Preparation Course

### Introduction:

CSWIP 3.2.2 Senior Welding Inspector will be capable of directing those operations associated with weldments and other types of joints that are completed in accordance with the appropriate contract documents, codes, and other standards to produce a satisfactory product & supervise and manage welding inspector.

### Who Should Attend?

- ▶ QC/ QA engineers
- ▶ Welding inspectors

### Course Duration:

5 Days

### Course Outlines:

- ▶ Metal joining and cuing processes
- ▶ How to manage and supervise welding inspectors
- ▶ Weld joint geometry and welding symbols
- ▶ Residual stresses and distortion
- ▶ Failure analysis.
- ▶ Radiographic Interpretation
- ▶ Nondestructive evaluation methods , symbols and Reports
- ▶ Welding safety
- ▶ Weld and base metal discontinuities

## W04-Welding Technology for Basic Welding Process

### Introduction:

The Certified Welding (CW) Engineer will be capable of directing those operations associated with weldments and other types of joints that are completed in accordance with the appropriate contract documents, codes, and other standards to produce a satisfactory product.

### Who Should Attend?

All personnel responsible for making decisions , exercising judgment applicable to welding operations in power generation , petrochemical oil and gas fertilizer, ship building and maintenance, structural fabrication, offshore and onshore structural fabrication.

### Course Duration:

5 Days

### Course Outlines:

- ▶ Metal joining and cuing processes
- ▶ Standard welding terms and definitions
- ▶ Weld joint geometry and welding symbols
- ▶ Residual stresses and distortion
- ▶ Welding metallurgy
- ▶ Metal properties and destructive testing
- ▶ Nondestructive evaluation methods and symbols
- ▶ Welding safety
- ▶ Weld and base metal discontinuities

## IN030-W05-WPS, PQR, WPQ Overview & Preparation and Electrodes Selection

### Introduction:

- ▶ To understand the welding process variables.
- ▶ To identify advantages and disadvantages of each welding process in different applications.
- ▶ To know how to choose suitable electrodes to different materials.

### Who Should Attend?

- ▶ Engineers & Technicians with good English.

### Course Duration:

5 Days

### Course Outlines:

- ▶ Introduction to welding consumables
- ▶ Classification of welding process
- ▶ Welding processes parameters (Current & Polarity)
- ▶ Welding positions
- ▶ Mechanical properties of metals
- ▶ Effect of alloying elements
- ▶ Different types of Welding Filler metals (Electrodes & Wires)
- ▶ Types of filler metal with the Welding processes (SMAW – MIG / MAG-TIG& SAW)
- ▶ Classification of welding electrodes & Wires according to (AWS, DIN, ISO,

BS)

- ▶ manufacturing of welding electrodes
- ▶ Applications & case studies

## **IN031-W06-Welding Metallurgy and Heat Treatment**

### **Introduction:**

- ▶ To understand the internal structure of different materials.
- ▶ To know the effect of welding heat on materials structure.
- ▶ To learn how to control the effect of welding heat on HAZ.
- ▶ To understand the effect of alloying elements on the internal structure of the materials

### **Who Should Attend?**

- ▶ Engineers & Technicians with good English.

### **Course Duration:**

5 Days

### **Course Outlines:**

- ▶ Principle of metallurgy
- ▶ Structure of metals
- ▶ Basic concept of solidification (Modes of solidification)
- ▶ Mechanical properties of metals
- ▶ Macro & microscopic examinations
- ▶ Iron carbon diagram
- ▶ Effect of alloying element
- ▶ Fusion welding processes
- ▶ Heat low during welding
- ▶ Temperature changes in welding
- ▶ Heat treatment of welded joint

- ▶ welding defects related to welding metallurgy
- ▶ Applications of welding metallographic



## **IN032-W07-Material Testing Evaluations**

### **Introduction:**

- ▶ To understand materials type and their chemical composition.
- ▶ To identify the properties of each type of material and how to evaluate.
- ▶ To understand heat treatment of several materials and how to obtain certain properties to certain function.

### **Who Should Attend?**

- ▶ Engineers & Technicians with good English.

### **Course Duration:**

5 Days

### **Course Outlines:**

- ▶ Classification of materials (Metallic & Non-metallic).
- ▶ Structure of metals.
- ▶ Ferrous & Non-ferrous materials.
- ▶ Mechanical properties of materials.
- ▶ Materials defects.
- ▶ Carbon steels.
- ▶ High strength steels.
- ▶ Alloy steels.
- ▶ Non-metallic materials (Polymers, Ceramics Composites).

## **IN033-W08-Material Selection, Receiving and Review of Mill Test Certificates**

### **Introduction:**

- ▶ To understand materials type and their chemical composition.
- ▶ To identify the properties of each type of material and how to evaluate.
- ▶ To understand heat treatment of several materials and how to obtain certain properties to certain function.

### **Who Should Attend?**

- ▶ Engineers & Technicians with good English.

### **Course Duration:**

5 Days

### **Course Outlines:**

- ▶ Classification of materials (Metallic & Non-metallic).
- ▶ Structure of metals.
- ▶ Ferrous & Non-ferrous materials.
- ▶ Mechanical properties of materials.
- ▶ Materials defects.
- ▶ Carbon steels.
- ▶ High strength steels.
- ▶ Alloy steels.
- ▶ Non-metallic materials (Polymers, Ceramics Composites).

**ME-Mechanical Courses :**

- ME01- Fundamentals of Mechanical Engineering
- ME02- Mechanical Engineering Basics for Technical Staff
- ME03- Pumps And Compressors (Mechanical)
- ME04- Pumps types, Construction, Operation& Maintenance
- ME05- Centrifugal Pumps Theory, Operation & Maintenance
- ME06-Centrifugal Pump Workshop
- ME07- Machine Alignment & Balancing
- ME08- Mechanical Seals Technology
- ME09- Compressors and Blowers Selection, Operation and Maintenance
- ME10- Compressors Technology Basics for Technicians
- ME11- Reciprocating Compressors Construction Operation and Maintenance
- ME12- Centrifugal Compressors Theory, Performance, Operation & Maintenance
- ME13- Advanced Centrifugal Compressor Technology Theory and Practice
- ME14- Turbo Expanders (operation & maintenance)
- ME15- Diesel Engines Construction, Operation & Maintenance
- ME16- Reciprocating Gaseous Fuel Engines
- ME17- Refrigeration and Air Conditioning For Engineers (Level 1)
- ME18- Refrigeration & Air Conditioning For Engineers (Level 2)
- ME19- Refrigeration And Air Conditioning For Engineers (Level 3)
- ME20- Refrigeration & Air Conditioning For Technicians

ME21- Absorption Chillers For Engineers

ME22- Air Cooled Exchangers for Engineers (Level 1)

ME23- Industrial Cooling Systems (Technical & Economical Feasibility Study)

ME24- Heat Exchange Equipment Operational Performance & Maintenance

ME25- Insulation & Refractory

ME26- Turbo-Machinery Monitoring and Problem Analysis

ME27- Vibration Protection Systems for Turbo-machinery

ME28- Basic Vibration for Technicians

ME29- Vibration Instruments and Conditioning Monitoring Systems

ME30- Bearing & Lubrication Technology

ME31- Rolling Bearings

ME32- Machinery Components Maintenance and Repair

ME33- Valves Fundamentals

ME34- Manual Valves (Advanced)

ME35-Mechanical Power Transmission

ME36- Hydraulic Circuits Theory, Components, & Practice

ME37- Hydraulic Equipment Operation, Maintenance & Troubleshooting

ME38- تشغيل و صيانه الاوناش و معدات الرفع-

ME39- Furnaces Technology

ME40- Fundamentals Of Gas Turbine Operation & Maintenance

ME41- Advanced Course In Gas Turbine Operation & Maintenance

ME42- Steam Generation & Boilers Operation and Maintenance

ME43-Process Vessels

ME44- Gaskets

ME45-Measuring tools

ME46- Hand Tools, Power Tools, MeasuringTools Fasteners

ME47-Pipe work and joints

ME48- Energy Saving & Managements in Thermal Equipment.

ME49- Safety Rules and Environmental Standards In Thermal Equipment Operations

## **ME01-Fundamentals of Mechanical Engineering**

### **Objective**

This intensive five days course is designed to provide personnel who have a mechanical engineering background or other technical personnel with appropriate training with awareness and basic skills in the fundamentals of mechanical systems, focusing on engineering considerations. The course emphasizes the important aspects of mechanical engineering for equipment and systems for oil and gas facilities. This course will focus on six areas: mechanical engineering principles and technologies, mechanical systems, non-rotating (stationary) equipment, rotating equipment, design of mechanical systems in facilities (particularly the interfaces with process, electrical, and pipeline areas), and operational and maintenance considerations. Individual and group exercises are used throughout the course.

### **Attendees will learn how to:**

- 1-Evaluate the application of mechanical components
- 2-Integrate the different mechanical systems during the design process
- 3-Apply the principles of mechanical engineering to petroleum facilities design, specification, and materials selection
- 4-Apply mechanical design principles of both rotating and non-rotating equipment
- 5-Consider mechanical issues in project design, construction, commissioning, and troubleshooting
- 6-Identify major mechanical equipment and systems operation and maintenance considerations

### **Who should attend:**

Mechanical, Process, Electrical, instrument and inspection engineers have relevant works to mechanical systems and machinery

### **Duration:**

5 days ( 20 Hours)

### **Course outline:**

#### **1- Fundamentals and Mechanical Technology:**

- o Mechanical Systems and Their Applications
- o Work, Energy and Efficiency
- o Energy: Generation and Transfer
- o Material Properties
- o Dynamic Response and Vibration

#### **2-Systems Considerations:**

- o System Definition, Availability, and Reliability
- o Control, Instrumentation and Relief Systems
- o Process Applications

- o Pipeline and Flow-line Applications

**3- Non-Rotating Equipment:**

- o Piping Systems
- o Pressure Vessels
- o Storage Tanks
- o Heat Exchangers
- o Heating, Ventilation and Cooling Systems
- o Safety Systems
- o Material Handling Systems

**4- Rotating Equipment:**

- o Motors
- o Engines
- o Turbines
- o Gear Systems
- o Pumps
- o Compressors
- o Generators

**5- Design, Construction And Commissioning:**

- o Plant Layouts
- o Hazard and Safety Analysis
- o Specification and Procurement
- o Construction
- o Inspection, Quality Control, and Quality Assurance
- o Commissioning and Startup

**6- Operations and Maintenance:**

- o Safeguarding, Monitoring and Inspection

**7- preventative Maintenance**

- o Sparing, Spare Parts, and Replacements
- o Vibration Monitoring

## **ME02- Mechanical Engineering Basics for Technical Staff**

### **Objective**

This five day course is designed to provide personnel who have an engineering background, with a guide to the fundamentals of mechanical systems. This course focuses on engineering considerations. The course emphasizes the important aspects of mechanical engineering for equipment and systems for oil and gas facilities. This course will focus on four areas: key mechanical engineering principles, stationary equipment, rotating equipment, and interfaces with other aspects of a facility, such as process, electrical and structural systems.

Understand the role of mechanical equipment and systems in production facilities, transportation systems, and process plants  
Recognize general codes and standards applicable to mechanical systems  
Distinguish mechanical equipment types and functions  
Identify varieties of mechanical drivers and driven equipment  
Recognize mechanical interfaces with process, electrical and structural systems

### **Who Should attend:**

Mechanical, Process, Electrical, instrument and inspection engineers?

### **Duration:**

5 days (20 Hours)

### **Course outline:**

- 1-Mechanical systems and terminology
- 2-Overview of codes and standards
- 3-Key principles of mechanical engineering
- 4-Mechanical equipment in oil and gas facilities
- 5-Pressure vessels and heat exchangers
- 6-Pipe, valves and fittings
- 7-Pumps and compressors
- 8-Fans and blowers
- 9-Air coolers
- 10-Drivers – Engines, turbines and electric motors
- 11-Interfaces with process, electrical and civil / structural systems
- 12-Interfaces with transportation systems and pipelines
- 13-Operations and maintenance considerations



## **ME03-Pumps And Compressors (Mechanical)**

### **Objective**

The “Pumps and Compressors” course is an intensive 5-day foundations level course that provides a comprehensive review of pump and compressor equipment used in the upstream and midstream sectors of the oil and gas business. Emphasis is on applications, design, selection and maintenance of such equipment.

### **Attendees will learn how to:**

Select, size and specify common pump and compressor equipment used in the oil and gas industry

Integrate pump and compressor equipment with piping and other systems

Identify physical principles and forces that occur in rotating equipment, focusing on pumps and compressors

Understanding of the principles of operation

Use operating and troubleshooting techniques for pumps and compressors

### **Who Should Attend?**

Mechanical & Process engineers and senior technicians.

### **Duration:**

5 days ( 20 Hours)

### **Course outline:**

Types and Applications of Pumps and Compressors

Thermodynamics of Compression

Centrifugal Compressors

Reciprocating Compressors

Rotary Screw Compressors

Other Compressor Types — Sliding Vane, Lobe

Effect of the Process on Compressor Selection, Control and Operation

Drivers – Engines, Turbines and Electric Motors

General Principles of Pumps

Centrifugal Pumps

Positive Displacement Pumps

Interface to Piping Systems

Vibration

Installation  
Operations and Maintenance Considerations.

# **ME04- PUMPS**

## **Types, Construction, Operation and Maintenance**

### **Objectives :**

The aim of this course is to enhance the knowledge and skills of participating engineers in the following topics: Types of pumps, centrifugal pumps, Axial-Flow pumps and positive displacement pumps. Emphasize is placed on the construction, operation, and maintenance of different types of pumps. Applications and different techniques of troubleshooting are also presented.

### **Who Should Attend:**

Maintenance & technical support engineers and supervisors.

### **Duration:**

5 days (20 hrs)

### **Course Outline:**

**Introduction and background**

**Characteristics of Pumping Systems and System Curves**

**Types of pumps:**

a. Positive Displacement Pumps

Reciprocating Pumps

Diaphragm Pumps

Gear and Screw Pumps

Vane Pumps

Axial piston pumps and radial piston pumps

Liquid-Ring Vacuum Pumps

b. Roto-dynamic Pumps (Centrifugal and Propeller Pumps)

**Centrifugal-Pump Construction:**

Impellers - casing - Wearing rings - Shaft and Shaft Sleeve

Packing and Stuffing Boxes - Mechanical Seals

Centrifugal Pump Packing

Centrifugal Pump Mechanical Seals

**Centrifugal Pump Performance**

**Centrifugal Pump Priming**

**Applications of Pumps in Industry**

**Pump Material and Corrosion**

**Selecting and Purchasing Pumps**

**Installation, testing and Operation of pumps**

**Maintenance and Troubleshooting**

# ME05-Centrifugal Pumps Theory, Operation And Maintenance

## **Objectives:**

The course is designed for engineers, supervisors and technicians involved in centrifugal pumps maintenance and operation. Participants will understand pump technology and performance. Participants will be able to determine different types of seals and bearings and their problems. It provides in-depth understanding of pump maintenance and overhauling procedures. Participants will practice hands-on inspection and measurements of pump parts. All participants will disassemble and assemble the pump for complete overhaul and report the pump condition before and after overhauling, with emphasis on practical hands-on parts inspection using the modern maintenance techniques and troubleshooting real-life examples.

## **Who Should Attend:**

Maintenance & technical support engineers and supervisors.

## **Duration:**

5 days (20 hrs)

## **Course Outline:**

### **Introductions**

#### **Pump Classifications**

- Dynamic pumps
- Positive displacement pumps

#### **Centrifugal Pump Design**

- Fluid concepts and velocity triangles
- Head and capacity calculation
- NPSH
- Specific speed

#### **Pump Performance**

- Pump characteristics
- Head capacity curve and operating point
- Effects of pump speed, impeller diameter and operating conditions
- Series and parallel operation and system head curves

#### **Pump Construction**

- Casing types
- Impeller/rotor
- Casing and impeller wear rings
- Seals and packing
- Bearings and lubrication

#### **Pump Operation**

- Start-up and shutdown conditions
- Minimum flow operation

Off-design operation

## **Pump Maintenance**

General maintenance procedure

Preparation for pump maintenance work

Checks before dismantling

Disassembly procedures

Removal of coupling

Dismantling of seals

Dismantling of bearings

Removal of rotor/impeller

Remove of casing and impeller wear rings

Parts Inspection, measuring and Repair or replacement

Precision Assembly Techniques

Installation procedure

Installation of shaft seals and packing

Installation of bearings

Check and set of clearances and axial play

Assembly errors

Proper fitting of shafts and bores

Proper set screw assembly

Effects of non-square faces

Care in assembly of couplings

## **Typical Pump Problems And Troubleshooting**

Cavitations

Liquid circulation

Vibration

Excessive power consumption

Failure analysis and troubleshooting

Seals and bearings common troubles

## **Specifications And Selection Techniques**

## **Pumps Maintenance Strategy**

## **Case Studies And Workshop**

## **ME06-Centrifugal Pump Workshop**

### **Objective:**

The Centrifugal Pump Workshop ( CPW) objective is to develop attendees skills and capabilities in performing C.P. maintenance . Emphasis is on plan and executes a C.P. preventive maintenance program, predict troubles and analysis measurements, using trouble shooting techniques, and carry out a complete C.P. overhaul with respect to health, safety and environmental regulations.

Attendees will learn how to :

- Proper using of hand and power tools.
- C.P. maintenance planning and scheduling
- Assembly & Disassembly procedures
- Complete pump overhaul
- Develop maintenance management skills

### **Duration :**

5 days ( 20 hours )

### **Who should attend :**

Mechanical maintenance engineers and technicians.

### **Course Outline:**

- 1. Centrifugal pump fundamental**
- 2. Centrifugal pump construction**
- 3. Centrifugal pump maintenance :**
  - Definitions and objectives.
  - Performance indications and measurement.
  - Maintenance economics.
  - Maintenance strategies.
  - Spare parts.
  - Disassembly and assembly procedures.
  - Coupling and alignment ( dial gauge & laser sets).
  - Complete pump overhaul.
  - Bearings and lubrication.
  - Monitoring technique.
  - Trouble shooting
  - Failure analysis and detection.
- 4. Establishing a planned maintenance program:**
  - Basic consideration
  - Appraising present situation
  - Goals of a PM program
  - Element of a PM program
  - Organizing maintenance function
  - PM scheduling

## **5. Pump predictive maintenance:**

Vibration basics

Transducers

Fault analysis

Implementation of a predictive maintenance system

# **ME07-Machine Alignment & Balancing**

## **Objective:**

One of the most common causes of damaging vibration in rotating equipment is shaft misalignment. This comprehensive course trains the student in the need for precision shaft alignment and instructs in the popular methods to achieve it. Classroom and actual field alignments are performed using dial indicators.

## **Who Should Attend:**

Maintenance, inspection & technical support engineers and supervisors

## **Duration:**

5 days (20 hrs)

## **Course Outline:**

### **Alignment theory**

**Alignment preparation**

**Measuring and correcting misalignment**

**Thermal growth effect**

**Alignment by rim & face method**

Formula

Graphic

**Alignment by reverse method**

Formula

Graphic

**7. Alignment by laser kit**

**7. Balancing Theory**

a. Balancing machine

b. Type of balancing

c. Methods of balancing

**8. Vibration for misalignment and balancing**



## **ME08-Mechanical Seals Technology**

### **Objectives:**

The course provides a comprehensive overview about different types of mechanical seals and their characteristics and applications. It also aims to enhancing the knowledge and skills of participating engineers in the modern methods of selection, Maintenance, Troubleshooting and Computer Usage.

### **Who Should Attend:**

Mechanical Design & Maintenance engineers, technical support engineers and supervisors.

### **Duration:**

5 days (20 hrs)

### **Course Outline:**

1. Overview (Packing and Seals)
2. Characteristics and Types of Mechanical Seals
3. Applications of Mechanical Seals
  - Mechanical seals in centrifugal pumps
  - Mechanical seals in compressors
4. Construction of Mechanical Seals
5. Materials of Seal's Components
6. Temperature Control of Mechanical Seals
7. Sealing and Flushing Fluids
8. Installation of Mech. Seals
9. Operation and Applications
10. Selection of Seals
11. Causes of Seal Failure
12. Computer Software
13. Maintenance and Repair
14. Troubleshooting of Seal Failure
15. Troubleshooting of Leakage

# **ME09-Compressors and Blowers** **Selection, Operation and Maintenance**

## **Objectives :**

The purpose of this course is to enhance the knowledge and skills of participating engineers in the following topics: Types of compressors, Screw compressors, Reciprocating Compressors, Centrifugal Compressors, Axial-Flow Compressors, Blowers, Characteristics and Performance of Compressors and Blowers, Maintenance and troubleshooting.

## **Who Should Attend:**

Maintenance & technical support engineers and supervisors.

## **Duration:**

5 days (20 hrs)

## **Course Outline:**

### **1. Overview**

Compression Methods  
Positive-displacement and rotodynamic compressors  
Types of blowers

### **2. Dry and Flooded Screw Compressors**

Applications and Maintenance

### **3. Reciprocating Compressors**

Description and Classification  
Applications and Maintenance

### **4. Centrifugal Compressors**

Description and Construction  
Performance, operation and Surge control  
Maintenance

### **5. Axial-Flow Compressors**

Description and Construction  
Performance, Surge control  
Maintenance

### **6. Blowers**

Types of blowers  
Description and Operation  
Applications and Maintenance

### **7. Lubrication**

### **8. Sealing and mechanical seals in compressors and blowers**

# **ME10-Compressors Technology Basics for Technicians**

## **Objective:**

The objective of this training course –Industrial Compressors Technology Basics – is to give a detailed overview about one of the widely used machinery.

The course is concentrated in construction, operation and maintenance of different types of compressors especially centrifugal and piston reciprocating.

## **Who Should Attend:**

This is a specialized course for those involved, directly or indirectly, in operation and maintenance of different kind of compressors.

The course is of a particular value for mechanical and process operation technicians and operators.

## **Duration:**

5 Days (20 H)

## **Course Outline:**

The course will be covered as follow:

### **Introduction and Definitions**

### **Overview and types of compressors.**

#### **Reciprocating compressors**

- \* Construction & theory of operation
- \* Operation & maintenance

#### **Centrifugal compressors**

- \* Construction & theory of operation
- \* Operation & maintenance

### **Cooling & Lubrication systems**

### **Maintenance and Trouble Shooting.**

# **ME11-Reciprocating Compressors** **Construction Operation and Maintenance**

## **Objectives:**

This course provides in-depth study of reciprocating compressors technology, performance, operation and maintenance. Participants will be able to solve operation and mechanical problems. Participants will practice a complete compressor overhauling and parts inspection at workshop and report the compressor condition.

## **Who Should Attend:**

This course is designed for maintenance engineers, supervisors and operation engineers of reciprocating compressors.

## **Duration:**

5 days course

## **Course Outline:**

- 1** Design Basis
  - 1.1 Gas thermodynamics and compression
- 2** Mechanical Design
  - 2.1 Design basics
  - 2.2 Allowable pressure and temperature
  - 2.3 Allowable speed
  - 2.4 Rod loading
- 3** Main Parts and Construction
  - 3.1 Frame and crankshaft assembly
  - 3.2 Cylinders and clearance volume
  - 3.3 Pistons, rods and packing
  - 3.4 Bearings
  - 3.5 Valves
- 4** Auxiliary Systems
  - 4.1 Frame and cylinder lubrication
  - 4.2 Cooling system
- 5** Accessories
  - 5.1 Compressor control system
  - 5.2 Piping system and gas filters
  - 5.3 Coolers and cooling system
  - 5.4 Suction and discharge snubbers
  - 5.5 Reduction gears, flywheel and coupling
- 6** Compressor Performance
  - 6.1 Ideal gas compression, power
  - 6.2 P-V diagram
  - 6.3 Actual operating conditions, valves behavior
  - 6.4 Characteristic curves
  - 6.5 Efficiency
- 7** Compressor Operation
  - 7.1 Start up and loading system

- 7.2 Capacity control
- 8 Maintenance**
  - 8.1 Disassembly and assembly procedures
  - 8.2 Crankshaft and bearings inspection\replacement and assembly
  - 8.3 Web deflection checks and adjustment
  - 8.4 Inspection repair and installation of cylinders
  - 8.5 Disassembly and assembly of piston and piston rods
  - 8.6 Adjusting end clearances of pistons
  - 8.7 Inspection and replacement of piston and rider rings
  - 8.8 Packing components inspection and assembly
  - 8.9 Oil scraper rings replacement
  - 8.10 Valves disassembly, inspection and assembly
  - 8.11 Frame lubricating system
  - 8.12 Cylinder lubricating system
- 9 Pressure Pulsation in Compressor and Piping**
- 10 Vibration Monitoring and Control**
- 11 Failures Analysis and Troubleshooting**
- 12 Pressure Pulsation in Compressor and Piping**
- 13 Specification and Selection**

# **ME12-Centrifugal Compressors** **Theory, Performance, Operation & Maintenance**

## **Objectives:**

This course is designed for engineers and supervisors involved in operation and maintenance and troubleshooting of centrifugal compressors. The course provides in-depth study of centrifugal compressors technology, performance, operation and maintenance. Participants will be able to solve operation and mechanical problems. Participants will practice a complete compressor overhauling and parts inspection at workshop and report the compressor condition.

## **Who Should Attend:**

Maintenance & technical support engineers and supervisors.

## **Duration:**

5 days (20 hrs)

## **Course Outline:**

Design Basis

Mechanical Design

Principles of operation & Construction

Principles characteristic of compressors

Lubrication seal system for centrifugal compressors

Lubrication a pairing system for centrifugal compressors

Compressor Operation

Start up and loading system

Surge & anti-surge control system

Centrifugal compressors protection

Maintenance

Disassembly and assembly procedures

Inspection repair and installation of cylinders

Oil seal replacement

# **ME13-Advanced Centrifugal Compressor Technology Theory and Practice**

## **Objectives:**

This course is intended for engineers and supervisors involved in operation, troubleshooting and maintenance of centrifugal compressors. The course provides in-depth study of centrifugal compressor technology. Performance, Mechanical parts, Seal systems and Maintenance are to some extent deeply introduced. Participants will be able to operation and mechanical problems related to centrifugal compressors.

## **Who should attend:**

Maintenance & technical support engineers and supervisors.

## **Duration:**

5 days (20 hrs)

## **Course Outlines:**

### **1. Introduction**

- Classification
- Arrangement.

### **2. Performance**

- Compression Cycle.
- Fan laws.
- Curve shape.
- Surge.
- Anti-surge control
- Choke
- Application notes

### **3. Mechanical Design**

- Casings.
- Diaphragms
- Casing connections
- Impellers
- Shafts
- Radial bearings
- Thrust bearings
- Lube oil system
- Bearing housing
- Balance piston
- Inter-stage seals

### **4. Shaft end seals**

Restrictive seals  
Liquid buffered seals  
Dry gas seal  
Seal Gas System  
Capacity control

**5. Maintenance**



# **ME14-Turbo Expanders**

## **(operation & maintenance)**

### **Objective :-**

Turbo Expanders are considered one of the most important energy recovery equipment by means of expansion.

This course gives a comprehensive understanding for this light weight equipment and helps attendees to be familiar with turbo expanders maintenance, operation & troubleshooting

### **Who should attend :-**

Technicians, maintenance & inspection engineers / supervisors

### **Duration :-**

5 Days (20 hrs)

### **Course outlines :-**

- Thermodynamic introduction featuring expansion methods for energy recovery
- Principle of operation
- Construction & design considerations
- Lube oil systems
- Vibration protection & axial position (automatic thrust balancer)
- Inlet guide vanes
- Bearings for expanders
- PFD's & process consideration
- Seal gas system
- Maintenance & troubleshooting

# **ME15-Diesel Engines**

## **Construction, Operation And Maintenance**

### **Objectives:**

This course is designed for maintenance and operation personnel, to provide a comprehensive understanding of engine technology, operation, performance and control. Participants will be attending a practical sessions for hands-on training at workshop, for a complete engine overhaul including parts dismantling, inspection measurement and assembly. Participants will practice failure analysis troubleshooting techniques from real available samples.

### **Who Should Attend:**

Mechanical, Maintenance and Process Engineers.

### **Duration:**

5 Days (20 H)

### **Course Outline:**

#### **Engine classifications**

#### **Engine operation parameters**

#### **Combustion and supercharging**

- Combustion process, combustion cycles and energy balance
- Control system for exhaust emission

#### **Engine construction and materials**

- Crankcase, crankshaft
- Fuel and injection system
- Dual fuel systems
- Combustion chambers
- Engine bearings
- Lubrication system
- Cooling and filtration systems

#### **Engine maintenance**

- Crankshaft and bearings assembly
- Piston and piston rings replacement
- Fuel pump and injectors dismantling, inspection and assembly
- Valve replacement and clearances check
- Setting of assembly parameters, valve clearances, oil pressure,
- Ignition system.

#### **Engine troubleshooting**

- Engine parts deposits & wear
- Incomplete burning process
- Bearing failure
- Cylinder bore polishing, scuffing and pitting
- Inspection of parts and analysis of results

#### **Engine characteristics and performance**

#### **Speed and fuel control systems**

**Vibration and noise control**  
**Engine selection and specifications**  
**Case studies**

# ME16-Reciprocating Gaseous Fuel Engines

## Objective :

Understanding gas engine theory and systems through the following:  
Gas engine operation theory compared to C.I. engine basic understanding Engine basic systems maintenance & repair Gas fuel types & properties knowledge Trouble shooting

## Who Should Attend:

Mechanical, Maintenance and Process Engineers.

## Duration:

5 days course

## Course Outline:

### **First day:**

- \*The principle of thermodynamics.
  - Forms of energy.
  - Available energy and efficiency.
  - Fuels available and composition.
- \*Introduction of internal combustion engines.
  - Classification of engines
  - Spark ignition engine (gas engine)
  - The 4-stroke cycle engine & p-v diagram.
  - Gas engine power and efficiency.
  - The stoichiometric mixture & mixture strength.
- \*Natural gas system
  - Gaseous fuels.
  - Heating values (higher & lower)
  - Octane rating
  - Analysis of the gas mixture.
  - Calculation of the lower heating value octane rating of the natural gas mixture.
  - Discussion on three (3) different gaseous fuels – (N/G, HD-5 propane & digester gas.)
  - Natural gas system description.
  - Gas over air tune – up & fuel system adjustment.

### **Second day:**

- \*The speed control system.
  - Hydraulic wood ward UG-8 governors.
  - Isochronous & droop operation.
  - Governor adjustment.

### **Third day:**

- \*Turbochargers.

- Theory of operation.
- Trouble shooting.
- Failure analysis.

\*Combustion, detonation and pre-ignition.

**Fourth day:**

\*Lubrication system.

\*Ignition system.

**Fifth day:**

\*Cooling system.

- Water quality.
- Cooling water treatment.
- Cavitations / erosion.

\*Engine top end overhauling.

- Cylinder head overhaul.
- Valve lash adjustment.

Free discussion & examination.

# **ME17-Refrigeration and Air Conditioning For Engineers (Level 1)**

## **Objectives: -**

Participants are to get knowing about:  
Refrigeration and Air conditioning fundamentals.  
Refrigeration cycles and components.  
Air conditioning systems.

## **Who should attend:**

Mechanical engineers and electrical engineers.  
Process Engineers.

## **Duration:**

5 days course

## **Course Outline:**

### **Introduction**

History.  
Refrigeration techniques.  
Psychometric analysis.

### **Air conditioning load estimation.**

Concepts.  
Methods.  
Design parameters.  
Peak load method.  
Worked examples.

### **Refrigeration cycles**

Vapour compression cycle.  
Absorption cycle.

### **Air conditioning systems**

Systems types.  
System components.  
Applications

# **ME18-Refrigeration And Air Conditioning For Engineers (Level 2)**

## **Objectives: -**

Participants are to get knowing about:  
Air conditioning systems components.  
Vapor compression cycle components.  
Troubleshooting and maintenance.

## **Who should attend:**

- 1- Mechanical engineers and electrical engineers.
- 2- Process Engineers.

## **Duration:**

5 days course

## **Course Outline:**

- 1. Air conditioning system equipments.**
  - a. Self contained units.
  - b. Split units.
  - c. Chillers.
  - d. Cooling towers.
  - e. Pumps.
  - f. Expansion tanks.
  - g. Air handling units.
  - h. Fan coil units.
  - i. Fans
- 2. Vapor compression cycle components.**
  - a. Compressors.
  - b. Evaporators.
  - c. Condensers.
  - d. Expansion devices.
  - e. Controllers.
- 3. Trouble shooting and maintenance.**

## **ME19-Refrigeration And Air Conditioning For Engineers (Level 3)**

### **Objectives: -**

Participants are to get knowing about:  
Testing and balancing of air conditioning systems.  
Commissioning for air conditioning systems.  
Troubleshooting of chilled water systems.

### **Who should attend:**

1. Field managers.
2. Mechanical engineers and electrical engineers.
3. Process Engineers.

### **Duration:**

5 days course

### **Course Outline:**

#### **Testing of air conditioning systems**

Equipment testing.  
Duct system testing.  
Piping system testing.  
Reporting test results.

#### **Balancing of air conditioning systems**

Duct system balancing.  
Piping system balancing.  
Reporting balancing results.

#### **Commissioning of air conditioning systems.**

**Troubleshooting and error diagnostic.**



# **ME20-Refrigeration And Air Conditioning For Technicians**

## **1. Objectives: -**

Participants are to get knowing about:  
Air conditioning systems.  
Air conditioning system equipments.  
Vapour compression cycle components.  
Troubleshooting.

## **Who should attend:**

1. Air conditioning technicians.
2. Air conditioning supervisors.

## **Duration:**

5 days course

## **Course Outline:**

- 1. Air conditioning systems**
  - Systems types.
  - System components.
  - Applications
- 2. Air conditioning system equipments.**
  - Self contained units.
  - Split units.
  - Chillers.
  - Cooling towers.
  - Pumps.
  - Expansion tanks.
  - Air handling units.
  - Fan coil units.
  - Fans
- 3. Vapour compression cycle components.**
  - Compressors.
  - Evaporators.
  - Condensers.
  - Expansion devices.
  - Controllers.
- 4. Trouble shooting and error diagnostic.**

# **ME21-Absorption Chillers** **For Engineers**

## **Objectives: -**

Participants are to get knowing about:  
Absorption system design, components and features.  
Absorption system evaluation and performance.  
Features of using absorption chillers in Egypt.

## **Who should attend:**

1. Field managers.
2. Mechanical engineers & electrical engineers.
3. Process Engineers.

## **Duration:**

5 days course

## **Course Outline:**

### **1. Introduction**

- a. The mechanical vapour compression cycle versus the absorption cycle.
- b. Direct field and indirect field machines.
- c. Description of an absorption chiller.
- d. Historical perspectives.

### **2. Theory**

- a. Types of Absorption cycles
- b. The single effect LiBr-H<sub>2</sub>O chiller flow diagram.
- c. The dehring diagram & thermodynamics state points.
- d. Enthalpy versus concentration diagram and state points.
- e. Operating conditions of single effect LiBr-H<sub>2</sub>O chiller.

### **3. Double effect machines**

- a. Double effect LiBr-H<sub>2</sub>O chiller flow diagram.
- b. Double effect LiBr-H<sub>2</sub>O heating mode diagram.
- c. Duehring diagram & thermodynamics state points.
- d. Operating conditions of parallel flow, double effect LiBr- H<sub>2</sub>O, cooling mode.

### **4. Absorption refrigeration in Egypt and the world today:**

- a. Global production of absorption units in the world.
- b. When is absorption feasible in Egypt.
- c. Future projects.

### **5. Specifying absorption units**

- a. The architect engineer role.
- b. The structural engineer role.
- c. The electrical engineer role.

- d. The consultant overall role
  - e. Crystallization and absorption cooling requirements.
  - f. Part load performance.
- 6. The Egyptian refrigeration and air conditioning code and absorption refrigeration.**
  - 7. Conclusion.**

## **ME22-Air Cooled Exchangers For Engineers (Level 1)**

### **Objectives: -**

Participants are to get knowing about:  
Air cooled heat exchangers types and selection.  
Air cooled heat exchangers design and evaluation methods  
Air cooled heat exchangers maintenance.

### **Who should attend:**

1. Field managers.
2. Mechanical engineers and electrical engineers.
3. Process Engineers.

### **Duration:**

5 days course

### **Course Outline:**

- 1. Introduction to air cooled heat exchangers.**
  - a. Types.
  - b. Applications.
  - c. Components.
  - d. Design requirements.
- 2. air cooled heat exchangers design and performance.**
  - a. Design procedure.
  - b. Components design requirements.
  - c. Evaluation.
- 3. End notes and maintenance.**
  - a. Material selection.
  - b. Maintenance methods and procedure.
  - c. End notes.

# **ME23-Industrial Cooling Systems** **(Technical & Economical Feasibility Study)**

## **Objectives :**

To provide participants with industrial cooling water systems description & performance as well as the technical & economical assessment of the systems. A typical case study is given.

## **Who Should Attend:**

Mechanical & Process Engineers, senior supervisors, technician

## **Duration:**

5 days (20 hrs)

## **Course Outline:**

- **Introduction**
- **Industrial cooling Systems (technical assessment):**
  - Once through
  - Dry cooling towers
  - Cooling ponds
  - Wet cooling towers
- **Process calculations :**
  - Once through
  - Dry cooling towers
  - Wet cooling
- **Towers :**
  - Economical study :
  - Capital costs
  - Running costs
  - Pay back period
- **Performance of system components**
  - Pumps
  - Heat exchangers
  - Cooling towers

# **ME24-Heat Exchange Equipment** **Operational Performance & Maintenance**

## **Objective:**

To provide operation, maintenance and technical support engineers with the Process Engineering Calculations, Material selection, Operational Performance & Maintenance of the main process Heat Exchange Equipment.

## **Who Should Attend:**

Engineers up to 5 years experience in maintenance, inspection and engineering departments.

## **Duration:**

5 days (20 hrs)

## **Course Outline:**

The course will cover, process calculations, operational performance, routine, preventive and predictive maintenance of the following main process heat exchange equipment:-

### **Process Heat Transfer**

- Heat transfer with & without phase change
- Thermal Insulation.

### **Shell & Tube Heat Exchangers**

- TEMA standards
- Process considerations
- Heat exchanger rating & performance
- Vapor Condensers.

### **Finned Tube Exchangers (Fin-Fan Coolers)**

- Products Condensers
- Preliminary selection
- Air Coolers Performance.

### **Wet Cooling Tower**

- Cooling tower calculations.
- Cooling towers performance
- Typical feasibility study  
(Technical & Economical Considerations)

### **Materials selection & corrosion for heat exchangers**

### **Maintenance of heat exchangers**

### **Manufacturing of Heat Exchangers.**

### **Tour to a big petroleum complex**

## **ME25-Insulation & Refractory**

### **Objectives:**

- The course is a refresher on basic concepts and calculations related to heat transfer and energy savings through the application of insulation.
- It describes the various types of thermal insulation materials available for use in industrial process plants.
- It characterizes thermal insulation types by their physical properties.
- It provides a basis for selecting the proper insulation type for particular industrial application.
- It describes proper installation and maintenance techniques to ensure that the thermal insulation will not degrade in service.
- It provides a number of case studies describing common insulation projects.

### **Who Should Attend:**

This course is taught to engineers and experienced technicians interested in using thermal insulation and refractories for reducing industrial plant heat losses or gains.

### **Duration:**

5 days (20 hrs)

### **Course Outline:**

- Introduction.
- Fundamentals of heat transfer.
- Insulation for low-temperature applications.
- Insulation for medium-temperature applications.
- High-temperature insulation and refractories.
- Insulation inspection and maintenance.
- Insulation shapes and configuration
- Reference tables and charts

# **ME26-TURBO-MACHINERY MONITORING AND PROBLEM ANALYSIS**

## **ABOUT THE COURSE**

This 5-day course is an intensive intermediate level program for experienced mechanical equipment engineers to develop and expand their capabilities in monitoring and problem analysis of turbo-machinery. Virtually all plants - power generation, oil and gas, gas transmission or process - include an assortment of the following items: gas turbines, steam turbines, compressors, pumps, blowers, fans, and electric motors. The plant will also have various accessories needed for this machinery such as couplings (flexible or otherwise), gearboxes, lube and seal oil systems, control systems and monitoring systems. Turbo-machinery systems are often a critical link in facilities operations and play a vital role in the facility performance. This course focuses on defining the systems and subsystems that form the turbo-machinery, the potential problems with these systems and subsystems, monitoring techniques for early detection, and methods to analyze the monitored variables to detect potential problems or reconstruct reasons for failures. Case studies are used throughout the course.

### **Attendees will learn how to**

- Evaluate turbine performance during startup and operation
- Identify turbo-machinery system components
- Define and use appropriate monitoring techniques and tools
- Utilize effective operation and shutdown procedures
- Analyze common turbo-machinery problems, such as vibration and surge
- Solve instrumentation and control problems
- Understand the inter-relationships of turbine drivers, couplings / gearboxes, and end users

### **WHO SHOULD ATTEND:**

Mechanical and process engineers and senior technicians.

### **DURATION :**

5 days ( 20 Hours)

### **Course Outline:**

- Gas turbine machinery - general description
- Operating principles of gas turbines
- Key performance variables and means to monitor
- Major components of axial flow compressors: rotors, blades, shafts,



combustion chambers, nozzles, etc.

Auxiliary systems: lube oil, seal oil, fuel, start up, etc.

Evaluation of turbine performance parameters during start up and running

Running and shutdown procedures

Troubleshooting control systems for gas turbines: start up, speed and temperature controls; vibration

Principles of operation and general components of compressors: rotors, seals, diaphragms, etc.

Operating characteristics curves

Surging phenomenon

Choking phenomenon

Compressor instrumentation: various control loops; anti-surge control loops

Compressor interlock and trip systems

Gas turbine and compressor systems start up procedures

Normal operation - monitoring of parameters

Logging of monitoring checks

Vibration monitoring

Troubleshooting

# **ME27-Vibration Protection Systems**

## **for Turbo-machinery**

### **Objective :-**

One of the most important protection systems for turbo-machinery is the vibration / axial position protection systems, through proper operation of these systems, safe operation could be guaranteed for turbo-machinery which represent a huge & capital investment and indeed is considered the heart of production plants

This course introduces the different types of installed vibration protection systems and helps attendees to be familiar with such systems and capable of performing maintenance / troubleshooting tasks.

### **Who should attend :-**

Technicians, maintenance & inspection engineers / supervisors

### **Duration :-**

5 Days (20 hrs)

### **Course outlines :-**

1. Introduction to vibration & basic definitions
2. Types of transducers & fixation schemes
3. Overall vibration concept
4. Vibration spectra & waveforms
5. Advanced techniques for analysis (orbit plots, phase, ... etc)
6. Steady / transient state analysis
7. Components of vibration protection systems
8. Typical installations
9. Maintenance / troubleshooting
10. Axial position systems
11. Testing & calibration of installed systems

# **ME28-Basic Vibration for Technicians**

## **Objectives:**

There are many systems available today that provide on-line or continuous monitoring of rotating plant machinery for Condition Based Maintenance (CBM). These systems range from relatively simple vibration switches which can provide alarm and machine shutdown information, to very sophisticated multi-channel monitoring systems which provide spectral processing, feature extraction, and expert data analysis to identify specific fault conditions and assess fault severity.

This course designed to help inspection and maintenance engineers, how to get benefits from vibration analysis systems to improve the accuracy of rotating machinery fault detection in condition monitoring systems.

## **Who Should Attend:**

Inspection, maintenance & technical support engineers & technicians.

## **Duration:**

5 days (20 hrs)

## **Course Outline:**

1. Velocity Pickups
2. Seismic velocity pickups
3. Direct-Prod. Velocity pickups
4. Accelerometers
5. Piezoelectric with built in amplifier
6. Non-Contact transducers
7. Mounting of transducers
8. Seismic velocity pickups & accelerometers
9. The shaft rider accessory
10. Guide lines for transducer selection

# **ME29-Vibration Instruments and Conditioning Monitoring Systems**

## **Objectives:**

There are many systems available today that provide on-line or continuous monitoring of rotating plant machinery for Condition Based Maintenance (CBM). These systems range from relatively simple vibration switches which can provide alarm and machine shutdown information, to very sophisticated multi-channel monitoring systems which provide spectral processing, feature extraction, and expert data analysis to identify specific fault conditions and assess fault severity.

This course designed to help inspection and maintenance engineers, how to get benefits from vibration analysis systems to improve the accuracy of rotating machinery fault detection in condition monitoring systems.

## **Who Should Attend:**

Inspection, maintenance & technical support engineers & technicians.

## **Duration:**

5 days (20 hrs)

## **Course Outline:**

- Velocity Pickups
- Seismic velocity pickups
- Direct-Prod. Velocity pickups
- Accelerometers
- Piezoelectric with built in amplifier
- Non-Contact transducers
- Mounting of transducers
- Seismic velocity pickups & accelerometers
- The shaft rider accessory
- Guide lines for transducer selection

# **ME30-Bearing & Lubrication Technology**

## **Objectives:**

The course provides a comprehensive overview for engineers seeking a working understanding of the basis behind the lubrication technology. The main purpose is to provide the basic background on the types and methods of lubrication. The participants will learn how to test and recognize the lubricant properties. Applications of lubrication in different hydraulic systems such as pumps, compressors and hydraulic equipment will be emphasized. Troubleshooting techniques and maintenance tips are also presented.

## **Who Should Attend:**

Maintenance & technical support engineers and supervisors.

## **Duration:**

5 days (20 hrs)

## **Course Outline:**

### **1. Elements of Lubrication**

- \*Bearings, Surface Bearings or Sleeve Bearings
- \*Lubrication Systems, Wear, Oil Filter Systems, Bearing Metals.

### **2. Basic Principles of Lubrication**

- \*Hydrostatic and Hydrodynamic Bearings
- \*Boundary Lubrication
- \*Elastic-Hydrodynamic Lubrication
- \*Tilting Pad Bearing, Bearing selection

### **3. Physical And Chemical Tests For Lubricants**

- \*Specific Gravity and API. Gravity
- \*Viscosity, Viscosity Index, ASTM Chart
- \*Flash Point Test
- \*Neutralization Number, Cloud And Pour Points
- \*Oxidation Tests & Other Tests
- \*Greases, Consistency, Melting and drop Point, Stability

### **4. Additives For Mineral Oils**

- \*Oxidation Inhibitors
- \*Anti-Wear Additives,
- \*Viscosity Index Importers
- \*Pour Point depressants, Anti-Foam additives
- \*Anti-Rust or Anti-Corrosion Additives
- \*Detergents, Oiliness Additives
- \*Bearing Corrosion additives, Extreme Pressure Additives

### **5. Grading and Selection of lubricants**

### **6. Lubrication Management**

### **7. Lubrication of Centrifugal compressors**

### **8. Filtration**

### **9. Troubleshooting Tips**

# ME31-Rolling Bearings

## objective :

The objective of this training course is to give a detailed overview about one of the widely used machinery component. This course is concentrated in types, operation and maintenance of different types of rolling element bearings.

## Who Should Attend?

This is a specialized course for those involved , directly or indirectly, in installation and maintenance of different kind of machinery . The course is of a particular value for maintenance ( Electrical and Mechanical ) engineers and technicians .

## Duration:

5 days (20 hrs)

## Course Outline:

### •Introduction and definitions:

- Bearing types
- Bearing Usage
- Rolling bearing codes & designation:
  1. Structure of code
  2. Bearing series (radial and thrust)
  3. Prefixes and suffixes
- Bearing selection table
- Bearing manufacturers comparison tables
- Split spherical roller bearings

### •Selection of suitable application bearing type:

- Load, speed and life calculations

### •Bearing storage and handling

### •Bearing mounting and dismounting:

- Tools and equipment
- Clearances, tolerance and fit
- Mounting and dismounting procedures

### •Bearing operation inspection

### •Bearing Maintenance:

- Bearing failure and trouble shooting
- Bearing failure causes and cure
- Recognition of damage and bearing inspection :
  - Unusual operation behavior indication damage.
  - Securing damaged bearings.

- Evaluation of running features and damage to dismantled bearings.
  - Means of inspection.
- Greasing and Lubrication.
- Bearing vibration analysis & prediction of failure causes.

## **ME32-Machinery Components Maintenance and Repair**

### **Objectives :**

This intensive course is designed for mechanical equipment engineers and experienced technicians to develop and expand their capabilities in monitoring and problem analysis of turbo-machinery. The course will cover the basis of process machinery maintenance as well as several machinery components principles, maintenance and repair. Trouble shooting techniques and turbo-machinery overhaul will be discussed.

### **Duration:**

5 days (20 hrs)

### **Who should attend :**

maintenance & technical support engineers and supervisors.

### **Course Outline:**

- I. **Process Machinery Maintenance**
  - a. Machinery Maintenance Overview.
  - b. Machinery Foundation and Grouting.
  - c. Process machinery piping.
  
- II. **Machinery Components Principles, Maintenance and repair**
  - a. Roller bearing
  - b. Fluid film bearing
  - c. Mechanical seal
  - d. Dry gas seal
  - e. Rotor and shaft
  - f. Gear, belt and chain
  
- III. **Monitoring and Trouble shooting**
  - a. Trouble shooting techniques.
  - b. Machinery trouble shooting.
  
- IV. **Turbo-machinery Overhaul**



# **ME33-Valves Fundamentals**

## **Objectives:**

The course provides a comprehensive overview about the basis behind the selection of different types of valves used in industry. In addition, it covers valve selection, installation, testing, troubleshooting and maintenance.

## **Who Should Attend:**

Maintenance & technical support engineers and supervisors.

## **Duration:**

5 days (20 hrs)

## **Course Outline**

### **1. An Overview**

- a. why valves?
- b. History of valves

### **2. Definition and nomenclature**

### **3. Types and classification of Valves:**

- a. Gate Valve
- b. Ball Valve
- c. Globe valve
- d. Piston valve
- e. Check valve
- f. Butterfly valve
- g. Plug valves

### **4. Selecting and specifying Valves**

- a. Pressure classes
- b. Valve coefficient
- c. Flow characteristics
- d. Shut off requirements
- e. Body material

### **5. Valve Installation**

### **6. Valve Operation and Applications**

### **7. Packing, Gaskets and Seals**

### **8. Valve Maintenance and Troubleshooting**

## **ME34-Manual Valves (Advanced)**

### **Objectives:**

The course provides for professionals seeking a working understanding of the basis behind the selection and design of different types of valves used in industry. In addition, it serves as a major forum for practicing engineers and field staff seeking a state-of-the-art update in valve selection, installation, testing, troubleshooting and maintenance. Codes and standards are covered in the course.

### **Who Should Attend:**

Maintenance & technical support engineers and supervisors.

### **Duration:**

5 days (20 hrs)

### **Course Outline**

- 1. Classification of Valves**
  - i. According to function
  - ii. According to application
  - iii. According to motion
  - iv. According to port size
- 2. Valve Selecting criteria**
- 3. Valve Installation**
- 4. Valve Operation and Applications**
- 5. Packing, Gaskets and Seals**
- 6. Control Valves**
  - i. Basic parts
  - ii. Settings
  - iii. Flow parameters
- 7. Pressure Relieving Systems**
- 8. Types of Actuators**
- 9. Valve Characteristics and Pressure Drop**
- 10. Valve Performance and system characteristics**
- 11. Energy Conservation in Valves**
- 12. Valve Maintenance and Troubleshooting**
- 13. Protecting Valve Wear by Cavitations**

## **ME35-Mechanical Power Transmission**

### **Objectives :**

This course aims at discussing power transmission methods, comparing between different ways from all aspects. The course covers the power transmission techniques with special attention to the suitability of the method to the function bearing in mind safety, and power losses. Optimization of various purposes and different methods is one of the course goals.'

### **Who Should Attend :**

Engineers and technicians who need to understand the problems which may affect the performance of rotating equipments due to power transmission.

### **Duration :**

5 days (20 hrs)

### **Course Outline:**

- P.T. by Gears.
- P.T. by Friction wheels.
- P.T. by Belts.
- P.T. by Chains.
- P.T. by Ropes.
- P.T. by Couplings.

# **ME36-Hydraulic Circuits**

## **Theory, Components, & Practice**

### **Objectives**

The aim of this course is to provide the trainees with a sound, basic background in the field of hydraulic circuits. As such, this course covers those subjects essential to understanding the design, analysis, operation and maintenance of hydraulic circuits. Theory is presented where desirable but the emphasis is placed on understanding how and why hydraulic circuits operate and on practical applications as well. Maintenance and troubleshooting of some hydraulic circuits will be covered in details.

### **Who Should Attend:**

Design & technical support engineers and maintenance, workshop engineers and supervisors.

### **Duration:**

5 days (20 hrs)

### **Course Outline:**

- 1. Basic Components of any Hydraulic Circuit**
  - \*Hydraulic Fluids and tanks
  - \*Pipes and Fittings
  - \*Hydraulic Pumps
  - \*Control Valves
  - \*Actuators (Cylinders and Motors)
  - \*An application to a simple hydraulic circuit.
- 2. Tanks and Hydraulic Fluids**
  - \*Design of tanks
  - \*Fluid properties and testing
- 3. Hydraulic Pumps (types of pumps)**
  - \*Gear pumps
  - \*Vane pumps
  - \*Piston pumps
- 4. Hydraulic actuators**
  - \*Hydraulic cylinders
  - \*Hydraulic motors (Gear motors, Vane motors, Piston motors)
  - \*Hydrostatic transmissions
- 5. Control Valves**
  - \*Directional-control valves
  - \*Flow control valves
  - \*Pressure control valves

**6. Accessories**

\*Accumulators

\*Pressure intensifiers.

**7. Applications: Hydraulic Presses, Loaders, Crânes, Hoists, ..... etc.**

**8. Maintenance and troubleshooting**

**9. Computer Simulation of Hydraulic Circuits**

# **ME37-Hydraulic Equipment** **Operation, Maintenance & Troubleshooting**

## **Objectives:**

The objective of this advanced short course is to provide the trainees with a strong background in the field of hydraulic equipment operation and maintenance. The trainee must finish the short courses on hydraulic circuits and pneumatics before taking this course. The emphasis is placed on understanding the operation of hydraulic equipment and how they are maintained. The equipment considered in this course are examples and other equipment of interest to the trainees may be considered.

## **Who Should Attend:**

Maintenance & technical support engineers and supervisors.

## **Duration:**

5 days (20 hrs)

## **Course Outline:**

1. Introduction: Basic Components of Hydraulic Circuits.
2. Selecting and Testing Suitable Hydraulic Fluids.
3. Installing Hydraulic Components.
4. Planning Hydraulic System Maintenance.
5. Methods and Techniques of Troubleshooting.
6. Troubleshooting Hydraulic Circuits.
7. Troubleshooting Valves
8. Troubleshooting Cylinders.
9. Troubleshooting Pumps
10. Troubleshooting cylinders and Motors
11. Applications:
  - \*Hydraulic Press.
  - \*Loaders
  - \*Excavators
  - \*Hydraulic Cranes
  - \*Utility Baskets

## تشغيل و صيانة الأوناش و معدات الرفع-ME38

### الهدف من البرنامج :

الهدف من البرنامج التدريبي هو تغطية كافة الجوانب المتعلقة بمختلف أنواع الأوناش ( البومة و الشوكة و أوناش الورش) من حيث التشغيل الآمن للمعدة و الأفراد ، كذلك تطبيق برامج الصيانة الوقائية للحفاظ على سلامة الأوناش و كفاءة عملها بأعلى معدلات الإتاحة و الإعتمادية ، لذلك فالبرنامج يتناول بالشرح و التفصيل الأجزاء المختلفة للأوناش بما فيها المنظومة الهيدروليكية و الأحبال و العربة من حيث التصميم الهندسي و التشغيل و الصيانة ، كذلك يتضمن وسائل الرفع و التصبين و التحميل و كيفية تصميمها و حسابات الأمان عند استخدامها و إجراء الاختبارات عليها للتأكد من كفاءتها للتشغيل .

### مدة البرنامج :

20 ساعة مقسمة على 5 أيام بواقع 4 ساعات يومياً .

### المشاركون :

البرنامج مصمم ليفيد جميع العاملين في تشغيل و قيادة الأوناش المتحركة و مساعديهم ، كذلك مستخدمى أوناش الورش و وسائل الرفع و التصبين المختلفة ، كما يفيد العاملين في صيانة الأوناش ، و البرنامج ذو قيمة لمشرفي الأمن الصناعي المشرفين على تشغيل مختلف أنواع الأوناش.

### محتويات البرنامج:

#### 1- تداول و رفع المواد

التداول و الرفع اليدوي

استخدام معدات يدوية فى الرفع و التداول

استخدام وسائل الرفع ( الأحبال و السلاسل و الصبانات )

استخدام الأوناش المتحركة و أوناش الشوكة و أوناش الورش

#### 2- تشغيل الأوناش المتحركة :

المعاينة اليومية للونش قبل التشغيل

احتياطات بدء التشغيل

معاينة الأحمال

تركيز الونش و رفع البومة ( جداول و خرائط الأحمال )

تصبين المواد و كود الإشارات

تشغيل الأوناش فى المناطق الخطرة Classifications of hazard areas

أجهزة التشغيل و التحكم و الأمان فى الأوناش

تشغيل و قيادة عربات الأوناش

تشغيل الروافع و الوصلات

اختبار صلاحية و أمان معدات الرفع

#### 3- الدوائر الهيدروليكية للأوناش :

مفاهيم أساسية

مكونات الدوائر الهيدروليكية (المضخات و المحركات- الاسطوانات - المشغلات - الصمامات -

الملحقات )

التصميم الهندسي للدوائر الهيدروليكية للأوناش

الرموز المستخدمة فى الدوائر الهيدروليكية

أعطال و طرق إصلاح الدوائر الهيدروليكية

#### 4- الأحبال

الأنواع المختلفة للأحبال

التصميم الهندسي للأحبال

الكود الدولي للأحبال الصلب API Standard for wire rope

اختبارات صلاحية و أمان تشغيل الأحبال

5- صيانة الأوناش

تعليمات و اعتبارات السلامة في صيانة الأوناش

التزييت و التشحيم

الصيانة اليومية للونش

برنامج الصيانة الوقائية للونش Preventive Maintenance Program

صيانة الأجزاء و الدوائر الهيدروليكية

صيانة الأحبال

صيانة العربة

الأعطال المختلفة و طرق علاجها Trouble Shooting



# ME39-Furnaces Technology

## Objectives:

This course is designed for engineers and supervisor including  
The references issue in the following topics which mentioned Bellow.

## Who should attend:

Engineers , supervisor and operation engineers

## Duration:

5 days (30 hrs)

## Course Outline:

### **1- introduction.**

### **2- Scope:**

- Definition of terms.
- Reference of publication .
- Furnace main components .

### **3- furnace classification :**

- according to draft
- according to types and shapes.
- Furnace attachments:
  - burners
  - soot blowers.
  - Air preheating .

### **4-design considerations:**

- General
- Design consideration for tubes
- Design consideration for stack ,duct and breeching

### **5-design .**

- Design limitation.
- Tube design.
- Stack, duct and breeching design.

### **6 - Furnace material:**

- Radiant tube material
- Convection tube material
- Header material
- Piping, terminal material
- Tube support material
- Refractories and insulation material
- Structure material
- Stack material

### **7-furnace performance.**

- Radiant section performance

- Convection section performance.
- Furnace efficiency.

**8- Instrument and auxiliary connection:**

- Tube – skin thermocouple
- Flue gas and air
- Process fluid temperature
- Auxiliary connection

**9- inspection:**

- General.
- Safety precaution before inspection and maintenance.
- Weld inspection
- Casting inspection
- Inspection for other components

**10-furnace maintenance:**

- Body and stack maintenance(casing and refractory)
- Radiant section maintenance
- Convection section maintenance
- Burner maintenance
- Soot blower maintenance
- Soot blower maintenance

**11- examination and testing:**

- Re-welding Examination
- .pressure testing
- refractory testing
- studded tube testing.

# **ME40-Fundamentals of Gas Turbine Operation & Maintenance**

## **Rationale**

Why it is important to learn this skill?

Gas turbines are a significant prime mover in industrial plant application. For this reason it is important for the technicians to understand the basic principles of operation and maintenance involving gas turbine.

## **Objective**

**When you have completed this course you will be able to:**

Describe the working principles, types, applications, systems, startup & Shutdown procedure, and gas turbine maintenance

## **Duration:**

5 days (30 hrs)

## **Who Should Attend?**

- Fresh graduate engineers
- Mechanical engineers up to 5 years experience in operating and maintenance Gas turbines
- Mechanical expert technicians up to 15 years experience

## **Course Outlines**

### **Objective one**

- 1) General description of the gas turbine and principle of operation
- 2) Gas turbine applications
- 3) The advantages and disadvantages of the gas turbine

### **Objective two**

- 1) Gas turbine operating cycles (open – closed)
- 2) Gas turbine simple cycle and its improvement

### **Objective three**

- 1) Gas turbine categories (single-dual- twin shaft) and its Applications
- 2) Gas turbine main components description and its types (air Comp. – Turbine- combustors)

**Objective four**

- 1) Other gas turbine components descriptions (air intake – exhaust  
Duct – seals – igniters – package – air bleed valve – IGV – fuel  
Nozzles)
- 2) General description of the gas turbine systems

**Objective five**

- 1) Lube oil system functional description
- 2) Lube oil system major maintenance items

**Objective six**

- 1) Fuel system functional description
- 2) Fuel system major maintenance items

**Objective seven**

- 1) Start system functional description
- 2) Start system major maintenance items

**Objective eight**

- 1) Air /exhaust system description
- 2) Air /exhaust system options

**Objective nine**

- 1) Background about the formation of NO<sub>x</sub>
- 2) NO<sub>x</sub> system description

**Objective ten**

- 1) Electrical control system types &function
- 2) Speed control

**Objective eleven**

- 1) Performance evaluation and factors affecting the turbine  
Efficiency
- 2) Gas turbine maintenance (monthly – annual – overhaul)

**Objective twelve**

- 1) Start up sequence
- 2) Shut down types and its sequences
- 3) List of most important malfunction shutdowns

**Objective thirteen**

Some of trouble shootings (Open discussion)

# ME41-Advanced Course In Gas Turbine Operation & Maintenance

## Rational

Why it is important to learn this skill?

Gas turbines are a significant prime mover in industrial plant application. For this reason it is important for the technicians to understand the principles of operation and maintenance involving gas turbine.

## Objective

**When you have completed this course you will be able to:**

- Describe the working principles, components, types, applications, systems,
- Startup & Shutdown procedure
- Regular Gas turbine maintenance
- Describe energy transformation in gas turbine engine
- Describe turbine engine performance and specifications
- Advanced methods of gas turbine maintenance (bore scope – condition monitoring)

## Who Show attend?

- Mechanical and instrumentation engineers whom are working in gas turbine operation and maintenance up to 10 years experience maximum.

## Duration:

5 days (30 hrs)

## Course Outlines

### **Chapter one –**

the gas turbine engine

- Basic cycle
- Advantages and disadvantages
- Applications

### **Chapter two –**

Gas turbine engine components

- Radial and axial air compressor
- Combustors and its types
- Turbine and its type

### **Chapter three –**

- Energy transformation in gas turbine
- Introduction in thermodynamics
- Enthalpy and kinetic energy
- Energy transformation in the air compressor
- Energy transformation in the combustors
- Energy transformation in the turbines

Examples using thermodynamics equations

**Chapter four –**

Fluid flow in gas turbine engines  
Surge and rotating stall  
Friction and turbulence  
Chock Flow

**Chapter five –**

Gas turbine engine performance and specifications

Leading particulars  
Compressor characteristics  
Turbine characteristics  
Component losses and matching  
Calculation of specific fuel consumption and equivalent speed and flow

**Chapter six –**

selected topics on gas turbine component design and manufacture

Introduction  
Properties of manufacturing materials  
Gas turbine cooling  
Manufacturing of turbine blades and vanes  
Accessory components

**Chapter seven –**

gas turbine maintenance “I”

Air inlet filtration  
Compressor blades erosion  
Compressor fouling  
Compressor Tip clang

**Chapter eight –**

gas turbine maintenance “II”

Inspection schedules  
Safety precautions  
Bore-scope inspections  
Cracks testing  
Bearings  
Fuel nozzles  
Condition monitoring instrumentation description

# **ME42-Steam Generation & Boilers** **Operation and Maintenance**

## **Objectives:**

The cost of fuel and the increasing interest in the environment ensure that the design and operation of boilers will be important for plant engineers and managers. This course provides a general description of boiler types and a short review of combustion fundamentals which are basic to an understanding of boiler operation. After that presents information on boiler fuels and describes burner types. The course covers the calculation of boiler inspection, safety and maintenance and concluded with technical efficiency and reviews measures that can be taken to improve efficiency. Finally discusses important aspects of boiler appendices.

## **Who Should Attend:**

Process engineers and technicians

## **Duration:**

5 days (20 hrs)

## **Course Outline:**

- Introduction
- Types of boilers
- Review of combustion fundamentals
- Boiler fuels
- Burners
- Boiler operation
- Boiler controls and instrumentation
- Efficient boiler operation
- Ancillary systems
- Boiler maintenance
- Case studies

# **ME43-PROCESS VESSELS**

## **ABOUT THE COURSE**

This 5-day foundation level course reviews the mechanical components design of process vessels in oil and gas facilities. The emphasis is on codes and standards (ASME Section VIII Div. 1 and Div. 2, BS 5500 and ISO), sizing calculations and materials selection, vessel specification, the sizing, design and support of nozzles and internals, fabrication including welding and inspection, and operations. Design problems are an integral part of this course.

### **Attendees will learn :**

Apply process vessel codes and standards for mechanical components of process vessels Size, select materials, and specify process vessels based on requirements from process design data

Consider support and internal appurtenances as part of the design and specification procedure

Integrate mechanical considerations in overall system design and operation

Understand the key elements of fabrication, welding and inspection of process vessels

### **Who Should Attend:**

Mechanical and inspection engineer and technicians .

### **Duration :**

5 days ( 20 Hours)

### **Course Outline :**

Pressure Vessel Codes and Standards

Vessel and Key Components Design

Corrosion Considerations

Materials Selection and Specification

Nozzle and Internals Design

Fabrication

Welding and NDT Inspection

Types of Vessels: o Separators o Towers o Slug Catchers o Heat Exchangers

Transportation and Erection

Interface to Piping Systems

Operations and Maintenance Considerations



## **M44- GASKETS**

### **Objective:**

- To be able to identify the different kinds of gaskets
- To be able to know the main function gaskets
- To be able to select ,and install different kind of gaskets.

### **Who Should attend :**

Helper, operator, workshop and maintenance technicians.

### **Duration :**

5 days ( 20 Hours)

### **Course Outline:**

1. **Gaskets**
2. **Paper Gaskets**

How to Cut the shaped paper Gaskets

3. **Rubber Gaskets**

How to cut the shaped Rubber Gaskets

4. **Cork Gaskets**

How to cut A circular cork Gaskets

How to cut the Bolt's holes in cork Gaskets

5. **Grease proof and varnished paper Gaskets**

How to cut a circular Grease proof Gasket

6. **Graphite impregnated asbestos gaskets**

Accurate method to manufacture A circular Graphite / asbestos Gaskets

How to cut A circular Gasket using cutting machine

How to cut A shaped Gaskets using transfer method

7. **How to manufacture A shaped gasket using layout**

Method by hammering

8. **Liquid gaskets ( Jointing Compounds )**
9. **Safety topics**

# **M45-MEASURING TOOLS**

## **Objectives:**

- To be able to identify the different kinds of mechanical measuring tools and parts.
- To be able to know the main function of each.
- To be able to learn how to use the mentioned mechanical measuring tools

## **Who Should attend :**

Helper, operator, workshop and maintenance technicians.

## **Duration :**

5 days ( 20 Hours)

## **Course outlines :**

### **MICROMETER**

Metric Micrometer

How to Read Micrometer (Metric)

Imperial Micrometer

How to Read Micrometer (Imperial)

How to operate the small size micrometers

### **VERNIER CALIPER Gauges**

Vernier Caliper (Metric)

How to Read Vernier Caliper (metric)

Vernier Caliper ( Imperial )

How to Read Vernier Caliper (Imperial)

### **MICROMETER DEPTH GAUGE**

How to measure the hole depth

## **VERNIER HEIGHT GAUGE**

VERNIER PROTRACTOR

Reading a vernier protractor

Dial gauges

Dial Test Indicator

Care of dial test Indicator

Correct methods of USING the dial indicator

Example for using the dial indicator

Testing for Roundness

# M46-HAND TOOLS, POWER TOOLS, MEASURING TOOLS & FASTENERS

## Objectives:

Introduction to the safety precautions on using hand & power tools. Have a tour through basic and mandatory hand & power tools found at workshop, introducing the specific use of each.

Learn the proper and safe usage of hand & power tools.

Identify common measuring tools, select the appropriate measuring tool for each job and learn how to use precision measuring tools.

Have a tour through the most common mechanical fasteners such as bolts, screws nuts and lock devices. Learn the proper usage and application of market found fasteners.

## Who should attend:

Maintenance engineers up to 5 years experience & technicians.

## Duration:

5 days (20 hrs)

## Course Outlines:

### 1. Safety Precautions

### 2. Hand Tools

Hammers      Wrenches      Chisels      Allen      Fluted Wrenches  
Punches      Hacksaws      Files      VISE  
Reamers      Cleaning Tools      Taps and Dies      Screw Drivers  
Pliers

### Measuring tools

Scale Ruler  
Micrometer  
Dial Caliper  
Screw Pitch Gauge

### 3. Bolts and Fixings

Screws  
Bolts  
Studs  
Bolts and Screw terminology

### 4. Power Tools

1. Drills  
2. Grinders  
3. Power Wrenches  
4. Mechanical Power Saw

### 5. Measuring Tools “detailed”

1. Outside Micrometer  
*Standard outside micrometer*  
Metric micrometer  
Using outside micrometer

- Digital micrometer
- 2. Inside micrometer
- 3. Micrometer depth gauge
- 4. Inside and outside calipers
- 5. Dial calipers and vernier calipers
- 6. Dividers
- 7. Screw pitch gauge
- 8. Feeler gauge
- 9. Steel Straight edge
- 10. Steel rules
- 11. Summary
- 12. Suggested Practice jobs
- 6. Bolts & Fixtures “detailed”**
  - 1. Machine screw.
  - 2. Sheet metal screw.
  - 3. Bolts.
  - 4. Studs.
  - 5. Nuts.
  - 6. Bolt, nut and screw terminology
  - 7. Machine Screw
  - 8. Locking Devices
  - 9. Screwdrivers
  - 10. Wrenches
  - 11. Taps and Dies
  - 12. Torque Wrench

## **M47-PIPE WORK & JOINTS**

### **Objectives:**

Introducing the use of piping and plant construction phases.

Introducing the process piping (Types, Sizes, Materials), how piping is jointed.(Different types of fittings) Have a glance through piping related codes and standards.

### **Who should attend:**

Engineers up to 5 years experience in maintenance of static equipment such as piping, valves, heat exchangers, ..etc. inspection, engineering departments and projects.

### **Duration:**

5 days (20 hrs)

### **Course Outlines:**

#### **1. PIPING:USES, AND PLANT CONSTRUCTION**

Uses of piping

Commissioning, designing & building a plant.

#### **2. PIPE, FITTINGS, FLANGES, REINFORCEMENTS, IN-LINE EQUIPMENT AND SUPPORT EQUIPMENT**

Process pipe.

Methods for joining pipe.

Components for Butt-Welded piping systems.

Components for Socket-Welded piping systems.

Components for screwed piping systems.

Flange Facings, Bolts & Gaskets.

Temporary closures for lines.

Quick connectors & couplings.

Joints & Flexible Piping.

Separators, Strainers, Screens & Drip-legs.

Reinforcements

Hardware for supporting piping.

#### **3. STANDARDS AND CODES FOR PIPING SYSTEMS, PIPE, PIPE SUPPORTS, FLANGES, BASKETS, FININGS, VALVES, TRAPS, PUMPS, VESSELS, HEAT EXCHANGERS, SYMBOLS AND SCREW THREADS**

What are standards & Codes?

Four reasons for their use.

Who issues standards?

Identifying the sources of standards.

## **M48-Energy Saving & Managements In Thermal Equipments**

### **Objective:**

The cost of energy has an active role in the cost of the industrial production. In the near future, the competition between the same production will be very strong in both quality and price. The objective of this short course is to develop the trainees knowledge and manners about the energies and how they can deal with the thermal equipment in the industrial processes to produce high quality and minimum operating cost.

### **Who should attend:**

Managers, design, operating and maintenance engineers.

### **Duration**

5 days (20 hr)

### **Course outlines**

- 1- Economical study
- 2- Performance evaluation of existing thermal equipment.
- 3- Design considerations for thermal operations
- 4- Modern methods for increasing the thermal equipment efficiency.
- 5- Burners and its efficient operation.
- 6- Waste heat recovery from industrial process.
- 7- Part load operation problems.
- 8- Parallel operation for thermal equipment
- 9- Predictive maintenance for thermal equipment.
- 10-Case study



# **M49-Safety Rules And Environmental Standards In Thermal Equipments Operations**

## **Objectives:**

Thermal equipments have many hazards on man and industrial establishments. Also, the exhaust of the thermal equipments cause environmental pollutions. This short course gives the trainees an overall definition for the best way to deal with this dangers using safety rules and environmental standard requirements.

## **Who should attend:**

Managers, design, operating and maintenance engineers.

## **Duration**

5 days (20 hr)

## **Course outlines**

1. Hazard sources in thermal equipments.
2. Industrial safety rules.
3. Thermal equipments safety design.
4. Thermal equipments safety operation.
5. Pollution sources in industrial processes
6. Environmental pollution standards.
7. Filters and filtrations processes.
8. SO<sub>x</sub> eliminations.
9. No<sub>x</sub> eliminations.

## **PR-Processing / Production Courses:**

PR01- Water Treatment Systems

PR02- Process Safety and Hazard Analysis (PHA &HAZOP)

PR03- Process Operations for Technicians

PR04- Hydrocarbon Storage, Shipping and Utilization

PR05- Fire Heater & Heat Transfer Equipment

PR06- Process Calculation and Simulation: by HYSYS

PR07- Oil & Gas Field Processing

PR08- Oily Water Treatment

PR09- Mass and Heat Balance in Petroleum Industry

PR10- Oil and Gas Separation Equipment

PR11- Gas Processing, Plant Troubleshooting & Startup

PR12-Gas Dehydration Technology

PR13- LPG Technology

PR14- Natural Gas Processing Technology

PR15- LPG, NGL & LNG Production and Handling

PR16- Crude Oil Processing and Desalting

PR17- Oil Refining Technology

PR18-Bulk Measurements and Accounting Loss Reduction

PR19-Combustion Techniques

PR20-Flare & Over Pressure Protection Systems

PR21-Furnace Operations outlines

PR22-Oil Movement, Storage & troubleshooting

PR23-Process Troubleshooting and problem solving

PR24-Shutdown & Turnaround Planning & Management

PR25-Surface Facilities Equipment -Advanced

## PR01-Water Treatment Systems

### Course Objective

Upon completion of the course participants will have gained a solid understanding of the key elements associated with the design, operation and troubleshooting of water treatment unit operations. Especially understanding the fundamentals of treatment .

### Who Should Attend

Junior and more experienced graduate engineers and technician looking for a specialization in the Oil & Gas processing activities. The course is particularly adapted to operations of the water treatment .

### Course Content

- Origin of petrol
- Water sources.
- Separation process.
- Environmental regulations
- Disposal Standards
  - Offshore Operations
  - Onshore Operations
- Factors affecting stability, pH and Ion strength
- Water treatment process and equipment design
- System Description
- Theory
  - Gravity Separation
  - Coalescence
  - Dispersion
  - Flotation
  - Filtration
- Equipment Used in Oil/Water Separation
  - Free Water Knockouts (FWKO)
  - Wash Tanks
  - Horizontal-Flow Treaters
  - Heater Treaters
  - Electrostatic Treaters

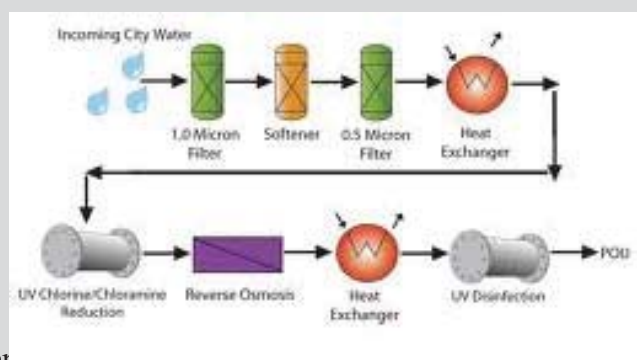

**Course Duration: (5) Days**

## PR02-Process Safety and Hazard Analysis (PHA &HAZOP)

### Course Objective

The risk review techniques most popular for initial PHAs of entire units or of large projects and PHA revalidations are hazard and operability (HAZOP) analysis

and what-if/checklist. Both of these techniques facilitate systematic, imaginative searches for process hazards and potential operational difficulties. In this course, you will also learn how to lead and participate in several analyses to familiarize yourself with each technique.

The Course focuses on human factors issues and how to analyze for human errors that can occur in step-by-step procedures. You will learn the original form of the HAZOP technique so you can effectively analyze procedures (startup, shutdown, normal batch operation, emergency operation, etc.) for the hazards of not performing a step as specified.

### **Who Should Attend**

This course will be particular interest to new engineers, supervisors.

### **Course Content**

- How to perform a PHA including these critical elements:
  - Preparing for the PHA
  - Scoping the PHA
  - Collecting information
  - Selecting the team
  - Leading a meeting
  - Documenting results
- How to analyze operating procedures for critical accident scenarios
- How and when to apply HAZOP, FMEA, and/or what-if/checklist analyses methods to process systems such as chemical, petroleum.
- Experience via realistic workshops



**Course Duration: (5) Days**

## **PR03-Process Operations for Technicians**

### **Course Objectives**

Upon successful completion of this program, trainees should be able to:

- Operate an oil refinery with safety as the prime consideration.
- Monitor instrumentation and the operation of equipment.
- Make adjustments to keep system process variables such as flows, temperatures and pressures within acceptable ranges.
- Detect potential and actual problems and take corrective action to prevent the interruption of system operations.
- Analyze operational trends and take corrective actions.
- Use standard operating procedures to start/stop production equipment
- Maintain communication with other operators, maintenance and the management.

### **Who Should Attend**

The program is ideal for personnel involved in refinery process operations, troubleshooting, and technical services as well as others providing services to the petroleum industry, should also find this program beneficial.

### **Course Contents**

This is a comprehensive course and consists of a number of learning modules. Each of the modules addresses a specific scope. This course consists of the following modules:

- Introduction to Petroleum Refining
- Distillation Technology
- Basic Refinery Processes
- Industrial Valves
- How to Read Process Drawings
- Basic Process Instrumentation and Control
- Pump Fundamentals
- Centrifugal Pumps – Operation
- Compressors



- Heat Exchangers
- Basic Safety
- Basic Hazard Communication
- Process plant startup / shutdown
- Troubleshooting

**Course Duration:** (5) Days

## **PR04-Hydrocarbon Storage, Shipping and Utilization.**

### **Course Objective**

This course presents a detailed overview of the storage facilities, shipping and Utilization.

Each refining, petrochemical and gas processing facilities have its own storage and shipping equipment which have several types of operating techniques and special troubles which will discussed with details.

### **Who Should Attend**

This course will be particular interest to new process engineers, process supervisor, and new technicians in relation to the important features of storage and loading facilities.

### **Course Outline**

1. Introduction to oil and gas industry.
2. Storage tank types.
3. Tank gauging.
4. Liquid volume calculations.
5. Tools and accessories used in tank farms.
6. Pumping stations.
7. Hydrocarbon consumption.



### **Course Duration: (5) Days**





## PR05-Fire Heater & Heat Transfer Equipment

### Course Objective

The course will cover all aspects of heat transfer equipment and fired heaters including safe operation and troubleshooting.

### Who Should Attend

This course will be of interest to engineers and personnel involved in Fired Heater operations having or requiring the basic understanding of direct fired heaters and who require knowledge of routine maintenance and troubleshooting issues.

Personnel may include plant operators, operating engineers, field service personnel, plant managers, and design engineers involved in the hydrocarbon processing, refining, and chemical processing industries.

### Course Content

- Introduction
- Heat Transfer
- Types of Heat Exchangers
- Shell and Tube Exchangers
- Double pipe Exchangers
- Air – Cooled Exchangers
- Heat Exchanger Operations
- Heat Exchanger Problems
- Principles of Heat Transfer in Fired Heater
- Fired Heater Designs
- Performance Monitoring
- Fired Heater Operation
- Troubleshooting

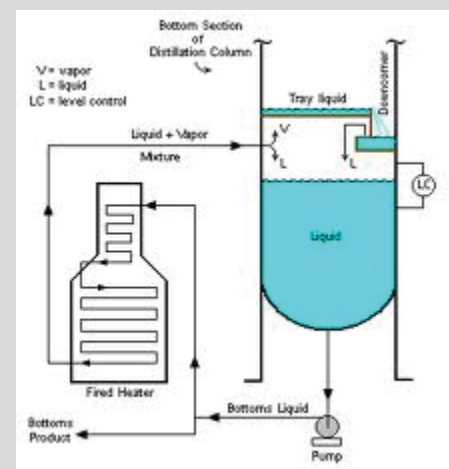

**Course Duration: (5) Days**

# PR06-Process Calculation and Simulation: by HYSYS

## Course Objective

The course will optimize engineering work processes using the full power and flexibility of Aspen HYSYS to build, evaluate and optimize flowsheets. Learn the shortcuts for efficient use of the software to build steady state simulations for Oil and Gas processes.

## Who Should Attend

New engineering graduates/technologists who will be using Aspen HYSYS in their daily work, Process engineers doing process design and optimization projects and studies, Plant engineers checking plant performance under different operating conditions.

## Course Content

- Introduction
- Hysys get started
- Hysys interface
- Main simulation problems and method to solve it.
- Steady state modeling
- Dynamic modeling
- Case study
- Report generation



## Course Duration: (5) Days

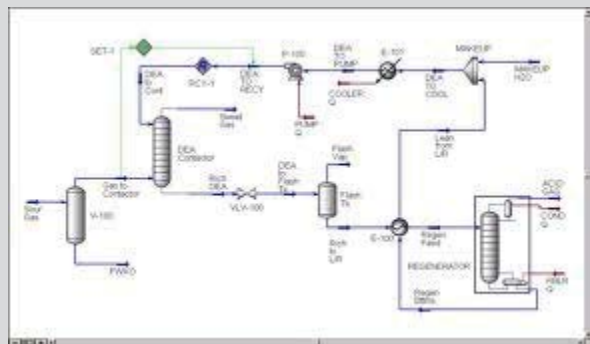

## **PR07-Oil & Gas Field Processing**

### **Course Objectives**

After completing this course, participants will be able to deal with Field equipment which have special operating instructions to be ready for archiving the required specifications of oil and gas for export or loading to main gas processing and oil refining plants.

### **Who Should Attend**

The program is ideal for personnel involved in oil and gas process operations, technical services as well as others providing services to the petroleum industry, should also find this program beneficial .

### **Course Contents**

1. Oil and gas wells arrangement and control.
2. Separation equipments
3. Primary treatment of crude oil
4. Oil desalting
5. Gas dehydration using glycol
6. Pumps and compressors
7. Storage and loading facilities

**Course Duration:** (5) Days



## PR08-Oily Water Treatment

### Course Objective

Upon completion of the course participants will have gained a solid understanding of the key elements associated with the operation and troubleshooting of oily water treatment units .

### Who Should Attend

Junior engineers and technician specialization in oily water processing activities

### Course outline

- Origin of petrol
- The History of Oil
- Water sources.
- Separation process.
- Characteristics of Produced Water
  - Dissolved Solids
  - Precipitated Solids (Scales)
    - Calcium Carbonate ( $\text{CaCO}_3$ )
    - Calcium Sulfate ( $\text{CaSO}_4$ )
    - Iron Sulfide ( $\text{FeS}_2$ )
    - Barium and Strontium Sulfate ( $\text{BaSO}_4$  and  $\text{SrSO}_4$ )
- Environmental regulations
- Disposal Standards
  - Offshore Operations
  - Onshore Operations
- Water chemistry issues
- Factors affecting stability, pH and Ion strength
- Chemical treatment
- Water treatment process and equipment design
- System Description
- Theory
  - Gravity Separation
  - Coalescence
  - Dispersion
  - Flotation
  - Filtration
- Equipment Used in Oil/Water Separation
  - Free Water Knockouts (FWKO)
  - Wash Tanks
  - Horizontal-Flow Treaters
  - Heater Treaters
  - Electrostatic Treaters

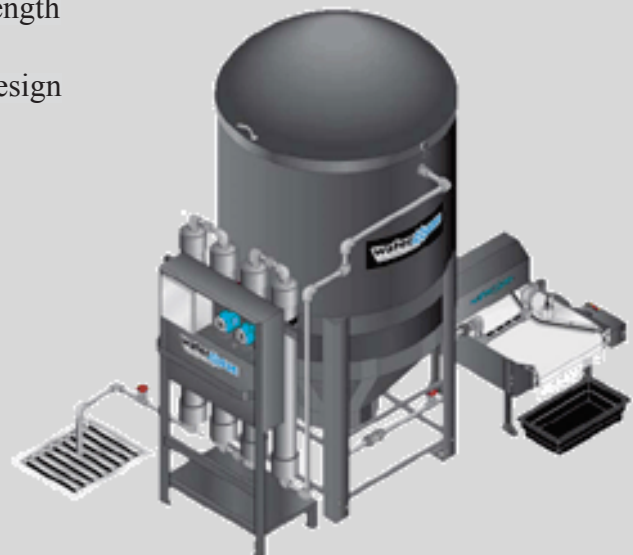
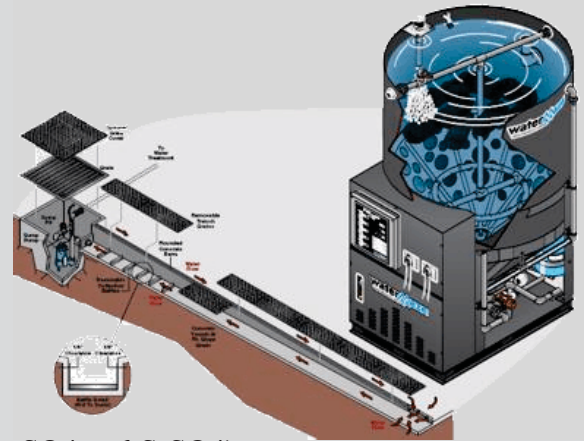

**Course Duration:** (5) Days

# PR09-Mass and Heat Balance in Petroleum Industry

## Course Objective

The objectives of this course on Mass and Heat Balance in Petroleum Industry, is to familiarize the attendees with basic heat and mass balance with concentration on case studies and simulation cases.

## Who Should Attend

Process and Operations engineers

## Course outline

- Fundamentals of material balance
- Single phase system
- Multiphase system
- Energy and energy balance
- Process simulation
- Case studies

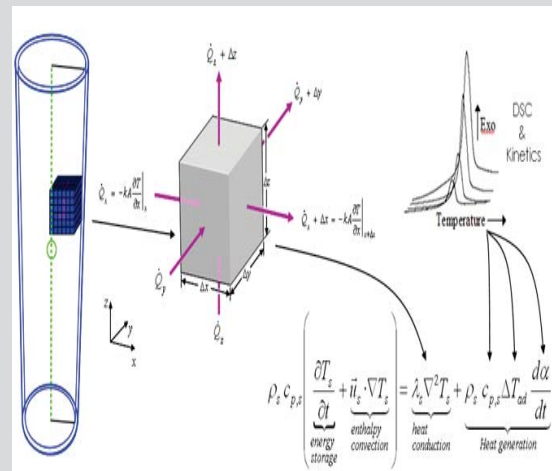

## Course Duration: (5) Days

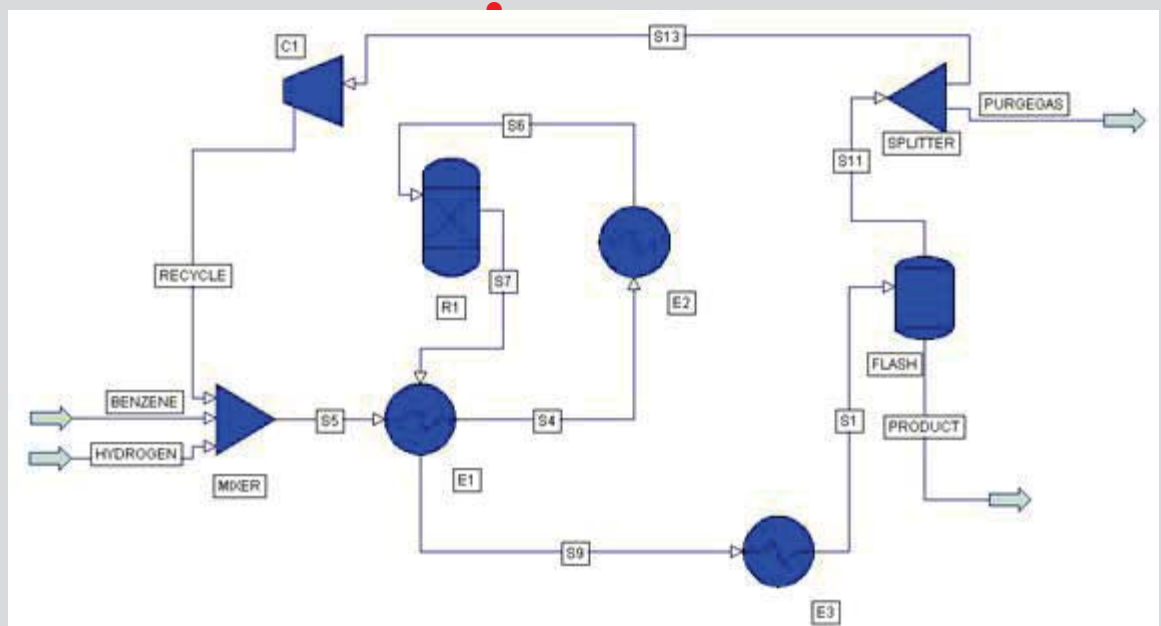

## PR10-Oil and Gas Separation Equipment.

### Course Objective

At the completion of this course the trainee will be able to:

- Identify and explain the function of each major component of the separator.
- Explain how separators work
- Explain when different separators are used.
- Describe how liquid levels and gas pressure are maintained in separators.
- Identify the safety devices for separators.

### Who Should Attend

This course is designed for Production Operators, Senior Operators, Mechanical and Instrumentation Technicians to become fully conversant with the Process of Separation in Vessels.

### Course outline

- Major Types of Separation Vessels
- Separator Contents
- Vessel Internals
- Separator Control Systems.
- Start-up and Shutdown Procedures.
- Safety Devices.

**Course Duration: (5) Days**

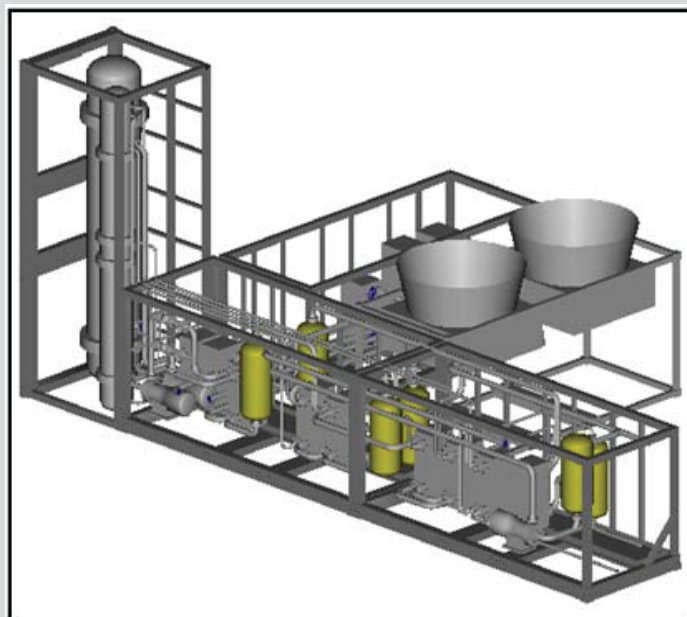
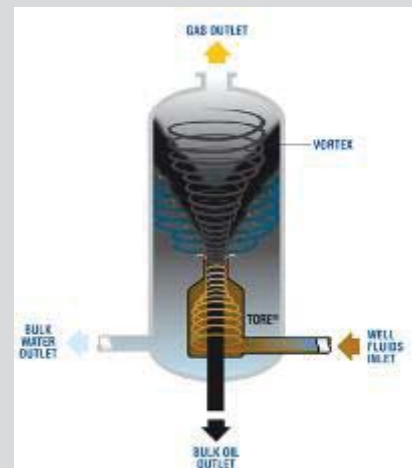

# **PR11-Gas Processing, Plant Troubleshooting & Startup.**

## **Course Objective**

The course will cover all aspects of gas plant processing including the main plant troubleshooting and startup with the most updated technology for plant operation .

## **Who Should Attend**

This course will be particular interest to new process engineers, process supervisor, and new engineers in relation to the important features of gas processing.

## **Course Content**

- oil and Gas separation
- Condensate Stabilization
- Sweetening processes
- Dehydration processes
- Refrigeration
- NGL recovery
- LPG / LNG
- Plant troubleshooting
- Planning plant shutdown
- Gas plant startup



**Course Duration: (5) Days**





# PR12-Gas Dehydration Technology

## Course Objective

The course will cover all aspects of gas dehydration systems with detailed description about natural gas water content calculation using mathematical and simulation methods and all types of gas dehydration systems will be explained .

## Who Should Attend

This course will be particular interest to new process engineers, process supervisor, and new engineers in relation to the important features of gas processing.

## Course Content

- Overview
- Water Hydrocarbon System Behaviors
- Water content calculations
- Gas Dehydration Systems
- Absorption Using Liquid Desiccants
- Adsorption Using solid Desiccants
- Hydrate Inhibition in Low Temperature Processing Plant
- Hydrate Inhibition in Gas Pipeline
- Process simulation
- Case study

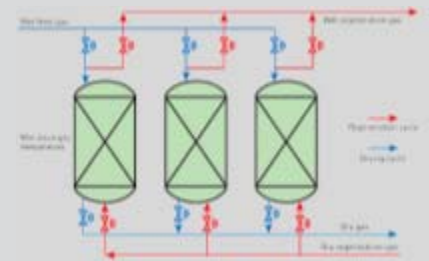

**Course Duration: (5) Days**



# PR13-LPG Technology

## Course Objective

This course presents a detailed overview of the Liquefied Petroleum Gas technology .

Each major recovery process is discussed, including feed stocks, feedstock preparation, operating conditions.

The course is oriented toward the practical aspects of LPG production operations as well as the terminology and economics of the Plants .

## Who Should Attend

This course will be particular interest to new process engineers, process supervisor, and new engineers in relation to the important features of gas processing.

## Course Outline

- Introduction
- LPG Recovery
  - From Natural Gas
  - From Crude Oil
- Theoretical Principles of Fractionation
- Fundamentals of Separation in Towers
- Fractionators Control, Operation & troubleshooting
- Physical Properties of LPG.
- Combustion of LPG
- Bulk Distribution & Handling of LPG

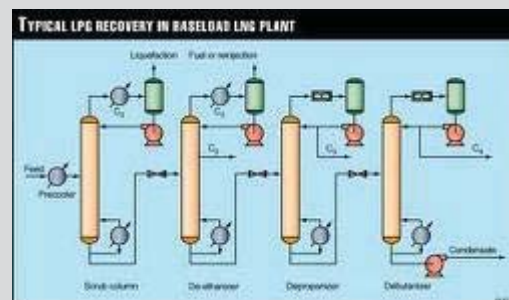

Course Duration: (5) Days

# **PR14-Natural Gas Processing Technology**

## **Course Objective**

The course will cover all aspects of gas plant processing including: review of the gas laws, calculations of natural gas properties, inlet separation, condensate stabilization, sweetening processes, dehydration processes (Glycol, M. Sieve, etc.), refrigeration, LPG fractionation and gas sweetening processes, the focus will be on important operating principles, process control variables, operating problems .

## **Who Should Attend**

This course will be particular interest to new process engineers, process supervisor, and new engineers in relation to the important features of gas processing.

## **Course Content**

- Composition and specifications related to natural gas processing physical properties.
- Basic gas calculations
- Gas separation
- Condensate Stabilization
- Sweetening processes
- Dehydration processes
- Refrigeration
- NGL recovery
- LPG / LNG



**Course Duration: (5) Days**

# PR15-LPG, NGL & LNG Production and Handling.

## Course Objective

This course is designed to give the attendants the fundamentals of natural gas handling systems and facilities including some of the details of the process. Specifically, by attending this course you will Gain a deep knowledge of the properties, specifications and uses of natural gas Gain an understanding of typical natural gas processing operations, including Dehydration and fractionation.

## Who Should Attend

This course will be particular interest to new process engineers, process supervisor, and new engineers in relation to the important features of gas processing.

## Course Content

- Definitions, physical properties, and primary uses of LNG, NGLs and LPGs.
- Overall supply/demand balances.
- Key drivers of supply, demand, and price.
- Gas conditioning
- Gas dehydration
- Amine sweetening plant
- Turboexpanders
- NGL recovery
- LNG Production
- LPG storage and transportation

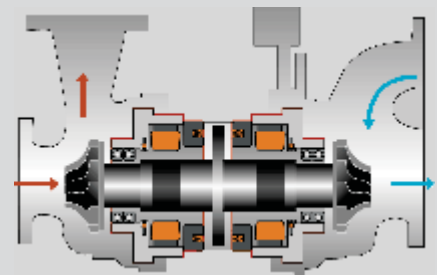

**Course Duration: (5) Days**

# PR16-Crude Oil Processing and Desalting

## Course Objective

This course is designed to give the attendants the fundamentals of Crude Oil Processing and Desalting systems and facilities including clarification of the most units used in oil processing facilities.

## Who Should Attend

This course will be of particular interest to new process / operation engineers, process supervisor, technicians and new engineers in relation to the important features of oil processing.

## Course Content

- Introduction
- Oil and Gas Separation
- Oil Desalting
- Fired Heaters
- Atmospheric Distillation
- Vacuum Distillation
- Storage tanks
- Pumps
- Flare and blow down systems



Course Duration: (5) Days

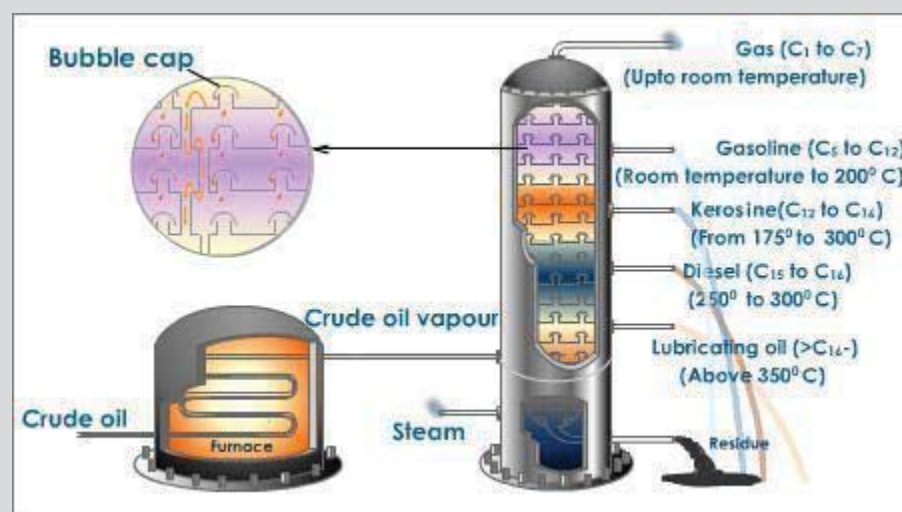

# PR17-Oil Refining Technology

## Course Objective

This course presents a detailed overview of the integrated fuels refinery of today.

Each major refining process is discussed, including feed stocks, feedstock preparation, operating conditions.

Methods for quality maintenance are reviewed as well as trends and methods for energy efficiency improvement. Anticipated changes in refinery feed stocks and product distribution are addressed.

The course is oriented toward the practical aspects of refinery operations as well as the terminology and economics of the integrated refinery.

## Who Should Attend

This course will be particular interest to new process engineers, process supervisor, and new engineers in relation to the important features of gas processing.

## Course Outline

The following topics are covered in the five-day course and are given in the approximate order listed:

1. **Overall refinery flow:** Interrelationship of processes.
2. **Feed stocks:** Crude oil compositions and properties and their effects on refinery operations.
3. **Crude Oil Separation:** Desalting, atmospheric and vacuum fractionation.
4. **Fired Heaters:** Types, operation, startup & shutdown
5. **Storage tanks :** types and new technology
6. **Flare and blow down system :** capacity and flare types

Course Duration: (5) Days

## **PR18-Bulk Measurements and Accounting Loss Reduction**

### **Course Description:**

This course is designed to enhance the understanding and application of Loss Control concepts for custody transfers for crude and products, as well as refinery, marketing, and pipeline monthly mass and volume balances

The course will also promote understanding and application of API standards for custody transfers. Loss control coordinators and engineers would have better technical understanding of custody contracts and reconciliation criteria between two parties in custody contract

The course will also moves into the refinery to explore the effects of crude oil type on refining yields and to examine the interactions between crude oil selection and refinery complexity

### **Course Objectives:**

The course will enable participants to develop overall System Capability of their respective plant or pipeline operations within which the system will provide a monthly balance. It will also enable engineers and operations to take steps to maintain their respective systems under control.

The course will also promote understanding and application of API standards for custody transfers. Loss control coordinators and engineers would have better technical understanding of custody contracts and reconciliation criteria

### **Who should attend?**

The course will be useful for new engineers, supervisors, Refinery Production Planning, Operations Department, process engineer, Lab Chemists and Marketing Accountant, as well as business groups who are involved in day-to-day custody transfers and mass and volume balances

## Course Outline

### Day 1: Introduction to Refining

- Nature of crude oils.
- Crude & product pricing.
- Refinery Products
- Basic Oil field Processes
- Basic Refinery Processes
- Petroleum Refining Operation
- Crude quality and productivity

### Day 2: Refinery material balance

- Introduction
- Process Classification
- Balances
- Material Balance Calculations
- Balances on Multiple-Unit Process
- Recycle and Bypass
- Chemical Reaction Stoichiometry
- Balances on Reactive Processes

### Case Study

- Actual material balance case studies during day

### Day 3: Storage Tanks

- Types of Storage Tanks
- Main parts of storage tanks
- Manual Level Gauging of Land Tanks
- Automatic Level Gauging of Land Tanks
- Free Water Measurements in Land Tanks
- Temperature Measurements in Land Tanks
- Manual Sampling of Land Tanks

### Case Study:

- Tank calculation, an actual examples

## Day 4 Petroleum Measurement Standards

- Proving Systems
- Metering
- Metering Assemblies
  - Lease Automatic Custody Transfer (LACT) Systems
  - Loading:-Rack and Tank-Truck Metering Systems For Non-LPG Products
  - Service Station Metered Fuel:-Dispensing Systems
  - Metering Systems for Aviation Fueling Facilities
  - Metering Systems for Loading and Unloading Marine Bulk Carriers
  - Pipeline Metering Systems
  - Metering Viscous Hydrocarbons

### ➤ Case Study :

## **Lessons Learned From Texas City Refinery Explosion**

### Day 5:

## **HP&LP Flare System**

- Emergency Vapour Depressurizing System
- Depressurizing System Requirements
- Flare Systems
- Venting to Atmosphere
- Disposal Back Into Process or Storage
- Main Flare
- Knock-Out Drum
- Water Seal Vessel
- Flare Stack
- Flame Arrestor
- Pilot Gas & Ignition System

### Case Study :

- Lessons learned from Deepwater Horizon oil spill



## **PR19- Combustion Techniques**

### **Introduction**

With the increase in the cost of energy and global warming looming in the wings, there is a question at hand. How do we minimize our cost of operating heating equipment, conserve energy and reduce carbon emissions (greenhouse gases) while maintaining heating performance?

The answer is, maximize the efficiency of existing furnaces and boilers, as well as verify the performance of newly installed high efficient equipment.

The only way to guarantee that a system is operating at maximum efficiency is to perform a combustion analysis and properly adjusting the air/fuel ratio.

This course is designed to provide the attendee with a full understanding of the combustion process, combustion test procedures and the adjustments required to maximize fuel efficiency.

### **Course Objectives**

By the end of this course, participant will be able to:

- Be familiar with Combustion Fundamentals
- Identify Characteristics of Turbulent Confined Diffusion Flames
- Understand the Laminar / Turbulent Premixed Flames.
- Understand Combustion, Heat Transfer, and Emission in Boilers And Furnaces.

### **Who should attend?**

This course is for facilities engineers, process engineers, operations personnel, field supervisors and others that select, design, install, evaluate or operate fired equipment and related facilities.

The course also includes;

- Group workshop and exercise.
- P.P. presentation.
- Videos

### **Course Agenda:**

## **Day 1: Combustion Fundamentals**

- Introduction
- Energy Sources
- Some Related Thermodynamic Fundamentals
- Combustion Stoichiometry
- Fuel/Oil/Air Ratio
- Combustion calculations

## **Day2:**

### **Flame types**

- Laminar Premixed Flames
- Turbulent Premixed and Diffusion Flames

### **Energy Balance**

- Steam boiler energy balance
- Fired heater energy balance

## **Day 3:**

- Combustion Control
- Fuel Gas Regulation
- Pilot Controls
- Feedback Fuel Control
- Heater Efficiency and Optimization
- Emissions monitoring & control
- Flue Gas Measurement
- Flame Detection

## **Day4: Combustion in fired heaters**

- Radiant section
- Convection section
- Tubes and header boxes
- Stacks and dampers

## **Day5: Fired Heater Troubleshooting**

- Flame Impingement
- Hot Spots
- Coking and Decoking
- Soot blowing
- Feed Pump Failure
- Fan Failure
- Valve Failure
- Burner Failure
- Instrument Failure
- Flame Out

## PR20-Flare & Over Pressure Protection Systems

### Course Description

In this course delegates will be familiar with aspects of FlareSystem Operation, with particular focus on the practical aspects of evaluating, selecting, installing and operating.

A proper understanding and execution of each of the above is a key in assuring a blow down system that operates at maximum efficiency and experiences minimal problems.

Understand design criteria and have a grasp of how to troubleshoot problems that can arise.

Delegates will be able to:

- Understand and enable candidates to operate Flare system competently.
- Identify and grasp of how to troubleshoot problems that can arise.
- Identify different types of flare system components.
- Review or provide flare, PSVs data sheets
- Review flare & blow down guidelines
- Follow relevant Code & standards, RP, COP, GL
- Understand all terminology related to flare & over pressure protection
- Identify flare design guidelines
- Identify overpressure protection guideline
- Operate flare & overpressure protection system smoothly and safely
- Isolate/de-isolate flare for major maintenance job or inspection
- Change standby flare to in service mode



Finally the delegates will be evaluated about his understanding of all topics covered through this course.

The course also includes;

Group workshop and exercise.

P.P. presentation.

Videos

**Who Should Attend**

Process /operation engineers, personnel, Specialists & technicians who are engaged in operating, maintaining, or trouble-shooting processing facilities.

# **PR21-Furnace Operations outlines**

## **Introduction**

The course presents a refresher of furnace and nomenclature, combustion, operations, burner and pilot types, instrumentation and controls, and safe heater operation. Personnel who operate fired heater equipment also require knowledge of troubleshooting common failures to effectively minimize operating difficulties. This course will provide a fundamental framework for this knowledge

## **Course Objectives**

By the end of this course, participant will be able to:

- Describe industrial combustion phenomena
- Calculate the air/fuel ratio,
- Identify bad-quality combustion from flue gas analysis and flame study,
- Implement corrective steps.
- List and apply the main steps of a furnace startup procedure
- Recognize the main operating and material constraints for an optimal, safe and reliable furnace operation.
- Understand the types of fired heaters and its selection.
- Understand Heat balance for furnace and fired heaters.
- Know the parts and trouble shooting for fired heaters

## **Who should attend?**

Shift Controllers, Supervisors, Senior operators

## **The course also includes;**

- Group workshop and exercise.
- P.P. Presentation.
- Videos



## **Course Agenda:**

## DAY ONE

### **Furnace construction and operating conditions:**

- Different types of furnace and their functions:
- Operating conditions.
- Distribution of heat.
- Efficiency and energy recovery.
  - Estimation rule.
  - Parameters governing furnace efficiency.
  - Scope and limitations for improving furnace efficiency.
- Construction of heat exchange areas and refractory materials:
  - Tube bundle arrangement.
  - Insulation.
  - Type of materials used and operating limits.

## DAY TWO

### **Combustion -Burners**

- Combustion conditions:
  - Stoichiometric air/fuel ratio
  - Heating value
  - Liquid and gas fuel characteristics
  - Liquid spray.
- Burners:
  - Fuel and air supply and mixture
  - Burner operation
  - Low NO<sub>x</sub> burner characteristics.
- Combustion quality:
  - Analysis of the oxygen and the unburned material in the flue gases
  - Control of the combustion air flow rate
  - Air/fuel ratio control.
- Combustion safety:
  - Flame detection,
  - Control and safety devices on the fuel circuits.
- Air and flue gas circulation:
  - Natural draft.
  - Forced draft.
  - Pressure differential control.
  - Automatic safety devices.
  - Damper or forced draft fan role.
  - Impact of furnace positive pressure.
- Application and Review of draft constraints and different types of burners and spraying systems.



## DAY THREE

## Furnace operation

- On-stream furnace operations:
  - Monitoring of combustion and heating.
  - Modifying operating conditions.
  - Analysis of disturbances.
  - Key points for safe operation,
  - Operating conditions control and follow-up.
- Start-up and shutdown:
  - Preparation,
  - Safe ignition procedures,
  - Ignition after a short shutdown,
  - Normal shutdown,
  - Emergency shutdown.
- Incidents:
  - Explosive atmosphere in the radiation zone,
  - Tubes rupture, unbalancing of the heat.
  - Diagnostic facilities.
  - Troubleshooting.
- Case studies
  - Case study of furnaces incidents.
  - Start-up procedure study.



## PR22-Oil Movement, Storage & troubleshooting

### INTRODUCTION

Upon the successful completion of this course, participants will gain enough knowledge on oil terminals and tank farms, Methods of gauging tanks, oil products specifications, tank mixing, emergency of oil spills, cleaning of crude oil tanks, cleaning of leaded gasoline tanks, work permit system, gas transmission pipelines, pigging operations in crude oil pipelines, quality assurance and control, contingency and safety procedures etc.

### WHO SHOULD ATTEND?

- Team Leaders, operators, terminal supervisor, Plant Supervisors, Process team, technical staff and contractor personnel involved in oil movement and storage

### Course Objectives

- Provide participants with a complete and up-to-date overview of the oil movements and storage operations in modern refineries, marine terminals and oil plants
- Acquire knowledge on oil production, recovery, dehydration and desalting and be able to understand the description and installation of a tank farm
- Identify the different types of tank and review and improve the operation of a tank farm
- Illustrate the process of gas freeing of tanks and vessels and be able to determine the various methods of gauging tanks
- Describe marine terminal operations and be able to explain the various product specifications
- Perform blending, tank mixing, meters and meter proving and cleaning of crude oil and leaded gasoline tanks
- Identify oil spill emergencies and be able to review the operation of gas transmission lines
- Increase knowledge on pigging of crude and gas pipelines and be able to demonstrate the process of ship loading

### Training Methodology

The course will be highly interactive, with opportunities to advance your opinions and ideas. Participation is encouraged in a supportive environment. To ensure the concepts introduced during the course are understood, they will be reinforced through a mix of learning methods, including lecture style presentation, and open discussion.

The course will be presented with the use of PowerPoint slides and videos. This will be augmented by case studies and facilitated discussions, to engage the delegates and to encourage the exchange of ideas.



## PROGRAMME SUMMARY

This course describes the requirements for efficient, effective, and safe operation of Oil movement facilities. This material is covered by concentrating only on the most commonly applied topics in each case, rather than attempting to discuss everything.

### *Course outline*

#### DAY 1 -

##### Overview Introduction

- Oil Production, Recovery, Dehydration and Desalting
- Oil Terminal & Tank Farm
- Types of Tanks
- General Description and Installation of Tank Farm

#### DAY 2 -

##### Tanks and Facilities

- Gas Freeing of Tanks and Vessels
- Methods of Gauging Tanks
- Static Electricity
- Crude Oil Processing
- Refrigeration of LPG, Handling and Bulk Storage

#### DAY 3 -

##### Blending and Loading Operations

- Marine Terminal Loading: SPM Operations
- Product Specifications and Blending
- Tank Mixing & Tank-Tank Transfer
- Meter Proving and Meter Factor

#### DAY 4 -

##### Aboveground Storage Tanks

- Emergency of Oil Spills
- Cleaning of Crude Oil and Leaded Gasoline Tanks
- Gauging of Marine Cold Product Tanks
- Gas Transmission Lines: Operation

#### DAY 5 -

##### Cleaning & Loading

- Pigging of Crude & Gas Pipelines

- Ship Loading and Checklist
- Quality Assurance, Control and Work Permit System
- Review and Presentation of Certificate

## **PR23-Process Troubleshooting and problem solving**

### **Course Description**

This course will give the trainee more understanding of the plant process operating technique also help to satisfy the requirements for training in the Troubleshooting at different scenarios and solving process problems for those whose job requires them to deal with oil and gas facilities including a review of process equipment, operating problems, and new technologies related to Oil and Gas processing, also cover the clarification of process problems with detailed troubleshooting.

The course also includes;

- Group workshop and exercise.

- P.P. presentations.

- Videos

### **Who Should Attend**

Process personnel, Production Supervisor / Engineers .

## COURSE AGENDA

### Day (1)

Plant over view.	08:00 am to 09:30 am
Process operating technique Natural gas platforms and its main processing problems (an actual examples)	
Rules of Thumb for Trouble Shooting	09:45 am to 11:30 pm
Historical examples	
Problem Solving Skills	11:45 am to 14:00 pm
Successful Plant Problem Solving	

### Day (2)

Data Gathering Skills	08:00 am to 09:30 am
Oil and gas separation trouble shooting	
<ul style="list-style-type: none"><li>• Classification Of Oil And Gas Separators</li><li>• Common components</li><li>• Separators troubleshooting, start up &amp; shutdown</li></ul>	
Condensate Stabilization pm	09:45 am to 11:30
<ul style="list-style-type: none"><li>• Multistage Separation</li><li>• Multiple Flashes at Constant Pressure and Increasing Temperature</li><li>• Distillation Tower with Reflux</li><li>• Stabilization system trouble shooting</li></ul>	
Problem solving case study	11:45 am to 14:00 pm

### Day (3)

Glycol dehydration and dew point control am	08:00 am to 09:30
<ul style="list-style-type: none"><li>• Principles of Gas Dehydration</li><li>• Affect of water content on dew point control systems</li><li>• Dew point control Methods</li><li>• Glycol Dehydration</li></ul>	09:45 am to 11:30 pm
<ul style="list-style-type: none"><li>• Problems related to Glycol Dehydration Process</li><li>• Optimizing and Troubleshooting Dehydrator Operations</li></ul>	

Solid Desiccant Dehydration

11:45 am to 14:00 pm

- Optimizing Adsorption-Type Dehydrators
- Solid desiccant dehydration trouble shooting

## Day (4)

Liquefied petroleum gas

08:00 am to 09:30 am

- LPG Recovery
- LPG Fractionators Control, Operation & Troubleshooting
- Quality Control & and product optimization

Petroleum product storage and transportation main problems

09:45 am to 11:30 am

Case study

Process Heaters main problems

11:45 am to 14:00 pm

Flare system and Fired equipment trouble shooting

Case study

## **PR24-Shutdown & Turnaround Planning & Management**

### **Course Description:**

Petroleum Industry is littered with examples of poor shutdowns with massive overruns in costs and problems in resource planning. Performing an effective shutdown is an example of applying many of the principles of good Project Management with some important exceptions which are outlined in the workshop. This workshop gives you an excellent review of shutdown management from the perspective of someone who has done it from the trenches.

There are many case studies of successful shutdown projects to ensure that you get the latest and most up to date information to successfully apply to your next project no matter what position you hold.

This course is designed to enhance the understanding and application of Loss Control concepts for custody transfers for crude and products, as well as refinery, marketing, and pipeline monthly mass and volume balances

The course will also promote understanding and application of API standards for custody transfers. Loss control coordinators and engineers would have better technical understanding of custody contracts and reconciliation criteria between two parties in custody contract

The course will also moves into the refinery to explore the effects of crude oil type on refining yields and to examine the interactions between crude oil selection and refinery complexity

### **Course Objectives:**

YOU WILL LEARN HOW TO:

- Describe typical turnaround management techniques
- Co-ordinate a simple turnaround project from planning to execution and handover
- Co-ordinate the personnel in a shutdown and turnaround project
- Apply shutdown best practices and planning
- Build an effective maintenance project plan for shutdowns
- Use critical path planning to identify risks and manage these risks effectively
- Plan to meet deadlines and complete turnaround projects within budget and on time
- Manage resources effectively on a turnaround project
- Develop the personal skills critical to effective turnaround project management
- Organise and improve performance to create a productive and competent team
- Evaluate and make immediate use of Turnaround Project Management Software packages

**Who should attend?**

Project Engineers , Shutdown Co-ordinators , Cost Control Staff , Construction Superintendents, Technical Personnel, Maintenance / Team Members

**Course Outline**

## Day 1: FUNDAMENTALS OF SHUTDOWNS AND TURNAROUNDS

- Overview & Introduction
- Structure of Shutdown Plan
- Critical Ingredients of Good Shutdown Management
- Typical Problems
- Co-ordination Issues
- Success Stories
- Not So Successful Stories

### **CASE STUDIE**

- LPG tanks

## Day 2: PLANNING AND SCHEDULING

- Management Plan & Procedures
- Scheduling Maintenance Activities
- Monitoring & Control Techniques
- Backlog Management Techniques
- Planning for the Shutdown
  - People
  - Materials
  - Work Permits & Isolation
- The Actual Shutdown
  - Implementation
  - Test & Acceptance
  - Variations to Contract
  - Progress Reviews & Deadlines
  - Tracking of Work
  - Controlling Time and Costs



- Post Shutdown
  - Reporting Systems
  - Review of Reports
  - Audit of Work Done
  - Punchlists

## **CASE STUDY**

- Distillation tower

## **Day 3: MAINTENANCE CONCEPTS**

- Measurement & Improvement of Maintenance Performance
- Maintenance Audits

## **HUMAN RESOURCES**

- Management of Contractors & Incentives
- Management of Claims
- Variations to Claims
- Liaison between Teams
- Organizational Charts
- Motivation & Team Building
- Training of Contractors
- Quality Control of Human Resources

## **MATERIALS & EQUIPMENT PLANNING**

- Definition of Equipment & Materials
- Interfaces between Different Equipment Packages
- Long Lead Times

- Off Site Construction & Suppliers
- Variations to Scope

## **CASE STUDIE**

- Oil field

### **Day 4 TIME MANAGEMENT OF SHUTDOWNS**

- Critical Path Method of Schedule Analysis
- Precedence Method of Schedule Analysis
- Presentation of the Schedules
- Resource Analysis
- Monitoring & Reporting Achieved Progress
- Selection of Software
- Case Study - Application of the Precedence Method Analysis Technique

### **COST MANAGEMENT OF SHUTDOWNS**

- Cost Estimation
- Budget Preparation
- Financial Control
- Change Control
- Cost Reporting
- Value Management
- Case Study - Preparation of a Project Cost Report

## **CASE STUDY**

- Oil Refinery

### **Day 5: RISK MANAGEMENT OF SHUTDOWNS**

- Risk Management Defined
- Risk Identification
- Risk Analysis
- Risk Management Responses

## **QUALITY IN SHUTDOWN MANAGEMENT**

- Definition of Quality & Management
- Quality Program
- Project Quality Assurance
- Quality Procedures

## **INTRODUCTION TO CONTRACT LAW ON SHUTDOWNS**

- Legal System
- Essential Elements of Contracts
- Factors Destroying the Legal Force of Contracts
- Termination of Contracts
- Breach of Contracts
- Liquidated Damages

## **CASE STUDY**

- Tank farm

## PR25-Surface Facilities Equipment -Advanced

### Course Description

This course will provide the participants with an integrated view of the oil & gas field production operation and related facilities. It will also present an advanced understanding of the wide range of oilfield production handling and treatment equipment. It will also provide the participants with an overall understanding of the process equipment. It is exceptionally useful for those who would like to obtain an overview of the oil & gas business, industry components, production technology and different recovery methods.

The purpose of this course is to present an overview and advanced understanding of the wide range of oil and gas production handling and treatment equipment. A major goal of this training is to improve communication among the technical disciplines, field and office in order to enhance operational efficiencies, lower costs and improve production economics. This course aims to ensure that best practices are shared and that right lessons are learned amongst our valued global community.

### Course Objectives

Towards the end of the training, participants will know :

- The Codes & Standard, Operating common troubleshooting, Isolate/de-isolate procedure/guidelines, Protection system for the followings:
  - Rotating Equipment:
    - Compressors.
    - Pumps.
    - Gas Turbines.
  - Instrument Air System
  - Static Equipment:
    - Heat Exchangers & Recovery Equipment.
    - Well test Equipment
    - Wellheads
    - Storage Tanks.
- Equipment performance evaluation tests.
- Performance curve for each equipment- if applicable
- Major Surface Equipment to fulfill the safe operation for hydrocarbons from wellhead to loading system.
- The major design guidelines for each equipment.
- Equipment common operating parameters & controls.
- Equipment common troubleshooting.
- Equipment startup / shutdown from / to different modes. (Vessel start-up after major maintenance job, power failure, stand by, different ESD levels,).



Who should attend?

- ✍ Process personnel, Junior Staff, Staff who want to increase their understanding of oil & gas process & operation.

Training Methodology

- 50% Lectures
- 30% Case Studies & Exercises
- 20% Videos & Discussions



Course Outlines

DAY ONE:

- 8:00-8:30 Registration
- 8:30-10:30 introduction
  - Oil and gas from wellhead to loading system
  - Major Surface Equipment in oil and gas fields
- 10:30-10:45 Break
- 10:45-12:00 Separation equipment
  - Types of separators
  - Separator internals
  - Function of major types
- 12:00-12:30 Prayer Break
- 12:30-14:00 Well Test Equipment (test separator, flow meters).
  - Water injection plant equipment
  - Major design guidelines
  - Automatic control
  - Separators troubleshooting

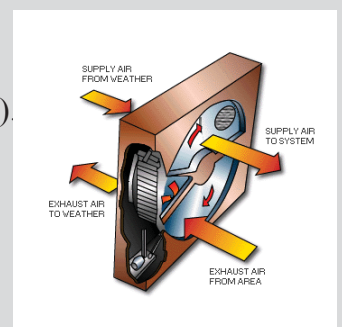

DAY TWO:

- 8:00-10:30 separator startup and shutdown  
Plant power failure

Instrument air failure

Codes & standards .

- 10:30-10:45 Break
- 10:45-12:00 Wellheads.  
Valves.

Control Valves, ESD, EDP, Manually Operated valves.

Relief valves.

Open & closed drain

- 12:00-12:30 Prayer Break
- 12:30-14:00 Plant isolation  
Case study

### DAY THREE:

- 8:00-10:30 Direct Fired Equipment.  
Fuel and combustion

Heaters internals

- 10:30-10:45 Break
- 10:45-12:00 Burners  
Pilots

Heater control

Indirect fired heaters

- 12:00-12:30 Prayer Break
- 12:30-14:00 fired heaters start up  
Troubleshooting

Case study



### DAY FOUR:

- 8:00-10:30 Storage Tanks.  
Types of storage tanks  
  
Fixed roof tank  
  
Floating roof tank
- 10:30-10:45 Break
- 10:45-12:00 spherical tanks  
Horizontal tanks
- 12:00-12:30 Prayer Break
- 12:30-14:00 stock calculations  
Tanks trouble shooting

### DAY FIVE:

- ✍ 8:00-10:30 Heat Exchangers.  
Main types  
  
Applications  
  
Trouble shooting
- 10:30-10:45 Break
- 10:45-12:00 Pumps.  
Compressor  
  
Fire Water System.  
  
Inert gas generation plant.
- 12:00-12:30 Prayer Break
- 12:30-13:45 CASE STUDY
- 13:45-14:00 Closing & Awarding of Certificates



## **L-Laboratory Courses:**

L01- Modern Oil and Gas Laboratory Management: Effective Management of analysis support

L02- Laboratory Quality Management (ISO 17025:2005) in Oil, Gas and LNG Plants: SOP, Accreditation, Documentation and Auditing

L03- Oil and Gas field Production Chemicals and Additives: Theory, Selection, Application and Troubleshooting

L04- Advanced Process Gas Chromatograph Analyzers: Operation, Application, Maintenance and Troubleshooting

L05- Gas Chromatography Operation, Application, Troubleshooting, Maintenance & Method Validation (Practical Approach)

L06-Good Laboratory Practice (GLP): Quality Control and Calibration of Lab Equipment

L07- Cooling Water Treatment Technology

L08- Atomic Absorption Spectroscopy (AAS)

L09- Boilers Water Treatment

L10- Reverse Osmosis Techniques (RO)

L11-Cooling Water Treatment Technology

L12- Advanced Course in Corrosion Control in Oil, Gas and Petrochemicals Production fields

L13- Corrosion Control and Monitoring fundamentals for Technicians



## L01-Modern Oil and Gas Laboratory Management: Effective Management of analysis support

### Course Overview

Analytical chemistry is experiencing dramatic, turbulent change beyond control of the laboratory and laboratory management. Technological innovations, staffing demographics, new business models, automation, industry consolidation, society and regulatory expectations, and other factors are transforming nearly aspect of the business. This course takes a strategic view of the laboratory system in the context of current quality management philosophies to determine options for achieving best practices. Experiences will be shared to provide insight into the obstacles and expected outcomes for the various approaches. Further this course includes the mission and function of the analytical enterprise along with ways to improve the quality, performance and evaluation of the laboratory.



In this course, you will learn how laboratories are applying current management philosophies to get closer to the business and to streamline operations. Practical details of laboratory management such as cost control, maintaining analysis quality, improving laboratory reputation, effective staffing, capital budget justification, and so forth will be discussed but the emphasis will be on systems rather than daily operational issues.

Participants are expected to share experiences and best practices.

### Learning Objective

Upon the successful completion of this course, you will be able to:-

- Apply modern management philosophies in your laboratory
- Get solutions to your management problems from a leading authority
- Define and focus on the lab mission

- Organize to meet the requirements of a mission
- Improve abilities to listen and communicate
- Motivate staff and build teams
- Recognize the manager's job.

### **Who Should Attend**

This course is intended for laboratory managers, supervisors, chemists, chemical engineers, analysts and scientists.

### **Course Outlines**

- Analytical Chemistry As Central Science in Science and Technology
- Activities *of Practicing Analytical Professionals*
- The Analytical Laboratory As Business Activity and Business Enterprise
- Vision and Mission, Goals, Planning and Organization (or Re-organization) of the Analytical Laboratory
- Human Resource Management for the Analytical Laboratory: Recruitment and Staffing
- Communication Management: Communications and Expectations
- Purchasing and Inbound Logistics Management: Capital Investments, Buying Costly Instruments
- Analytical Laboratory Space Management: Design and Management of Physical Laboratory Space
- Management and Leadership: Organization and Decision-Making
- Human Resource Management for the Analytical Laboratory: Placement, Incorporation, Training, Development, Performance Appraisal, Motivation and Staff Retention
- Laboratory Operation Management
- Laboratory Performance Management: Quality Management, Good Laboratory Practice Compliance and Names Accreditation
- Financial Management: Expense and Capital Budget, Cost Control
- Information Management and LIMS.
- Benchmarking

- Future developments.
- Approach to Improving the Analytical Laboratory

# L02-Laboratory Quality Management (ISO17025:2005) in Oil, Gas and LNG Plants:SOP, Accreditation, Documentation and Auditing

## Course Overview

This course is a comprehensive look at the latest revision (2005) of the ISO 17025:2005 and its documentation and internal auditing requirements. You will gain critical insight on the interpretation of the requirements of this laboratory standard and you will also receive a detailed review of the accreditation process.



You will learn how to design and develop laboratory documents and quality manuals. The quality manual will be examined as to its impact on laboratory operations and what purpose it serves. You will learn what information it should contain, what writing style is most effective and how to keep your documents and quality manual up to date.

This course also gives attendees the knowledge needed to establish an internal quality audit program as required by ISO 17025:2005, and to initiate the sequence of activities involved in scheduling, planning, conducting, reporting on and closing out internal quality audits. Participants will be able to employ effective techniques of auditing and the ability to develop the auditing procedures, scheduling and recording systems needed to sustain the program.

Attendees will receive practical instructions on the development, implementation and long-term maintenance of an effective laboratory quality system.

In addition to the updated knowledge provided to course participants during the course period, each participant will go back to his/her laboratory

equipped with an outstanding manual that includes typical SOPs that can be modified and used within participant's laboratory

### **Learning Objective**

Upon the successful completion of this course, each participant will be able to:-

- Get certified as an "ISO 17025 Auditor"
- Apply the latest techniques in laboratory quality management and its standard operational procedures, accreditation, documentation and auditing (laboratory auditing) in accordance with ISO 17025:2005
- Recognize the requirements of an ISO 17025:2005 accreditation and review the accreditation process
- Design and develop laboratory documents (SOP) & quality manuals and recognize the information they should contain, employ an effective writing style as well as maintain documents and quality manuals up to date
- Carryout an internal quality audit program in accordance with ISO 17025:2005 as well as initiate the sequence of activities involved in scheduling, planning, conducting, reporting on and closing out internal quality audits
- Employ effective techniques of auditing and develop auditing procedures, scheduling and recording systems needed to sustain an auditing program
- Develop, implement and maintain a long term effective laboratory quality system in the long run in compliance with the requirements of ISO 17025:2005.

### **Who Should Attend**

This course is suitable for laboratory managers, superintendents, supervisors, chemists and analysts. Further, this workshop will be of great value for quality managers, quality engineers, quality auditors and management representatives.

### **Course Outlines**

- Accreditation
- ISO/IEC 17025:2005 What the Standard Requires:

- 15 Management Requirements
- 10 Technical Requirements.

- Preparation of Documentations.
- Internal Audits of the laboratory.
- Role Play on Audit activities.

# **L03-Oil and Gas field Production Chemicals and Additives:Theory, Selection, Application and Troubleshooting**

## **Course Overview**

Chemicals treatments are essential to obtain qualified product of oil and gas activities. Using proper chemicals with correct system will improve efficiency of Oil and Gas activities particularly for Off-shore facilities. Wide range of chemicals and additives are being successfully used in oil fields to treat oil, gas and water systems. Such chemicals include; but not limited to; Demulsifiers, pH stabilizers, R.O. chemicals, Oxygen scavengers, Scale inhibitors, Biocides, Corrosion Inhibitors,...etc.

This course focuses on those products that commonly used at oilfield production. Emphasis will be placed on field cases and troubleshooting instead of theoretical aspect. This course is offering everything the professional and the novice need to know about Theory, Selection, Application and Troubleshooting of Oil and Gas field Production Chemicals and Additives.

Production engineers, facility engineers, chemical engineers, laboratory chemists, oilfield service chemicals personnel and also for anyone who put concern of chemicals performance at oilfield will regard this course as the best in Oil field chemicals and additives. In addition to serving as an invaluable update for the experienced practitioner, this course provides the beginner with a solid understanding of Oil and gas fields' chemicals and additives theory and basic techniques.

This state-of-the-art course incorporates the most recent developments and applications in the field of Chemicals and additives within oil and gas facilities, including topics on introduction of chemicals and additives, function principles of each chemical, selection of a successful

additive, synchronization and synergy, methods of chemicals dosages and injection, updated information on chemicals and additives application, troubleshooting and useful hints for optimization.

This course presents a well-rounded and comprehensive overview of the current state of this important technology, providing an invaluable knowledge that will greatly appeal to both experienced production and operations team and novices not only for oil and gas treatment chemicals and additives but also for water treatment facilities. Furthermore, course will provide solid understanding for safe handling of those chemicals and additives.

### **Who Should Attend**

Production engineers, facility engineers, chemical engineers, laboratory chemists, oilfield service chemicals personnel and also for anyone who put concern of chemicals performance at oilfield will regard this course as the best in Oil field chemicals and additives. In addition to serving as an invaluable update for the experienced practitioner, this course provides the beginner with a solid understanding of Oil and gas fields' chemicals and additives theory and basic techniques.

### **Course Outlines**

The following program is planned for this course. However, the course instructor(s) may modify this program before or during the course for technical reasons with no prior notice to participants. Nevertheless, the course objectives will always be met:

- Introduction to oilfield chemicals and additives.
- Understanding the function and principle of operations of the following chemicals and additives:
  - Demulsifiers,
  - Oxygen and H<sub>2</sub>S scavengers,
  - Biocides,



- Scale inhibitors,
  - pH stabilizers,
  - R.O. chemicals and additives,
  - Corrosion inhibitors,
  - Hydrate control and removals.
- Understanding all methods of chemicals treatment and selection of proper methodology.
  - Verifying the proper selection of chemicals and additives (bench scale and field testing).
  - Understand the concept of synergy (positive and negative synergy).
  - Safe handling of chemicals and additives (MSDS and Hazards)
  - Verifying proper operation of chemicals and additives.
- Apply the latest techniques on troubleshooting of chemicals and additives for oil and gas fields with a special focus on off-shore facilities

# L04-Advanced Process Gas Chromatograph Analyzers:Operation, Application, Maintenance and Troubleshooting

## Course Overview

Quality management just makes sense. You need to know how to make it

a part of your organization. In this course, you'll review advanced quality management principles, best practice techniques, tools, and skills. You'll find these concepts useful in a wide range of businesses and organizations including

manufacturing, service, government, education, and healthcare. The use of Gas Chromatography plays a key role in the modern industry, not only by supplying effective data of known quality, but also providing these data in real-time or near real-time.

This course is offering everything the professional and the novice need to know about running, maintaining, and interpreting the results from Online Process Gas Chromatography analyzers. Analytical chemists, technicians, Maintenance engineers and Operations team in allied disciplines will regard this course as the best in Online Process Gas Chromatography analyzers. In addition to serving as an invaluable updates for the experienced practitioner, this course provides the beginner with a solid understanding of gas chromatographic theory and basic techniques.

This state-of-the-art course incorporates the most recent developments in the field of Online Process Analyzer Gas Chromatography, including topics on optimization of separations and computer assistance; high speed or fast gas chromatography; mobile phase requirements: gas system



requirements and sample preparation techniques; qualitative and quantitative analysis by Gas Chromatography; updated information on detectors; validation and QA/QC of chromatographic methods; and useful hints for troubleshooting gas chromatographs.

This course presents a well-rounded and comprehensive overview of the current state of this important technology, providing an invaluable knowledge that will greatly appeal to both experienced chromatographers and novices.

### **Who Should Attend**

This course is offering everything the professional and the novice need to know about running, maintaining, and interpreting the results from Online Process Gas Chromatography Analyzers. Analytical chemists, technicians, Maintenance engineers and Operations team in allied disciplines will regard this course as the best in Online Process Gas Chromatography analyzers. In addition to serving as an invaluable update for the experienced practitioner, this course provides the beginner with a solid understanding of gas chromatographic theory and basic techniques.

### **Course Outlines**

The following program is planned for this course. However, the course instructor(s) may modify this program before or during the course for technical reasons with no prior notice to participants. Nevertheless, the course objectives will always be met:

- Understanding Gas Chromatography and a Gas Chromatograph
- Using the Basic Chromatograph System in Process Gas Analysis
- Understanding Carrier and Calibration Gas Systems
- Using the Chromatograph to Identify Problems
- Setting Timed Events, Retention Times, and Response Factors
- Starting Up a Gas Chromatograph
- Understanding Sample Handling Systems

- Verifying Proper Operation of the Gas Chromatograph
- Conducting Preventative Maintenance
- Apply the latest techniques on operation, application, troubleshooting and method validation of Online Process gas chromatography analyzers.

# L05-Gas Chromatography Operation, Application, Troubleshooting, Maintenance & Method Validation (Practical Approach)

## Course Overview

The use of Gas Chromatography plays a key role in the modern industry, not only by supplying effective data of known quality, but also providing these data in real-time or near real-time.

This course is offering everything the professional and the novice need to know about running, maintaining, and interpreting the results from Gas Chromatography. Analytical chemists, technicians, and scientists in allied



disciplines will regard this course as the best in gas chromatography. In addition to serving as an invaluable update for the experienced practitioner, this course provides the beginner with a solid understanding of gas chromatographic theory and basic techniques.

This state-of-the-art course incorporates the most recent developments in the field of Gas Chromatography, including topics on optimization of separations and computer assistance; high speed or fast gas chromatography; mobile phase requirements: gas system requirements and sample preparation techniques; qualitative and quantitative analysis by Gas Chromatography; updated information on detectors; validation and QA/QC of chromatographic methods; and useful hints for troubleshooting gas chromatographs.

In this way, the participants will get the benefits of using the course instruction in an applied situation to develop their own GC method. Further, participants will analyse the process, make adjustments and control the instrument, which will give them the most benefit from this course.

This course presents a well-rounded and comprehensive overview of the current state of this important technology, providing an invaluable knowledge that will greatly appeal to both experienced chromatographers and novices.

The course manual is a very comprehensive and contains many special topics that cover modern applications of GC in numerous disciplines. It is a must-have reference on the shelves of all laboratories doing Gas Chromatographic analysis.

### **Learning Objective**

Upon the successful completion of this **practical/hands-on course**, each participant will be able to:-

- Apply proper techniques on operation, application, troubleshooting and method validation of gas chromatography
- Carryout sampling, sample handling and sample preparation
- Differentiate between packed columns & capillary columns as well as carryout chromatographic processes and component separation
- Discuss the general considerations when selecting capillary columns
- Describe gas chromatographic separation effects, carryout column selection, installation and use
- Carryout sample injection, discuss the general considerations, factors effecting injection, and types of injection methods
- Identify different types of GC detectors such as thermal conductivity detectors, flame ionization, electron capture, thermionic, photoionization, flame photometric and chemiluminescent detectors
- Carryout GC validation methods, troubleshooting and applications.

### **Who Should Attend**

This course is offering everything the professional and the novice need to know about running, maintaining, and interpreting the results from Gas Chromatography. Analytical chemists, technicians, and scientists in allied

disciplines will regard this course as the best in gas chromatography. In addition to serving as an invaluable update for the experienced practitioner, this course provides the beginner with a solid understanding of gas chromatographic theory and basic techniques.

### **Course Outlines**

- Sampling and sample preparation.
- Gas Chromatograph components and main function.
- Gas Chromatographic Separation Effects
- Column Selection, Installation and Use
- Sample Injection
- Packed and Capillary column.
- GC Detectors
- GC Method validation.
- Quality Assurance and Quality Control.
- Gas Chromatography Maintenance.
- Troubleshooting and Applications

# **L06-Good Laboratory Practice (GLP): Quality Control and Calibration of Lab Equipment**

## **Course Overview**

This online course covers the requirements for the qualification of laboratory instruments, including IQ, OQ, and PQ. The relationship between vendors, user requirements specifications and qualification are explained. The different approach to simple and complex instruments is addressed, and specifications and calibration requirements for spectrophotometers, chromatographic systems and dissolution apparatus are reviewed.

## **Learning Objective**

- Describe the steps involved in IQ and OQ of instruments.
- State the requirements for software qualification.
- List chromatography instrument calibration requirements and frequency.
- List general lab instrument calibration requirements and frequency.
- State the QC expectations for instrument logbooks.

## **Who Should Attend**

This course is offering everything the professional and the novice need to know about Good Laboratory Practice and instrument calibration. Analytical chemists, technicians, and scientists in allied disciplines will regard this course as the best in gas chromatography. In addition to serving as an invaluable update for the experienced practitioner, this course provides the beginner with a solid understanding of GLP and Quality Control.

## **Course Outlines**

- QC REGULATIONS AND QUALIFICATION
  - Introduction
  - Instrument calibration
  - Useful definitions



- Good QC laboratory data
- Applying the V model
- Simple vs complex instruments
- Qualification phases
- Vendors
- Lab instrument specialist
- INSTRUMENT QUALIFICATION
  - Introduction
  - Instrument URS
  - Qualification approach
  - Steps of IQ
  - System suitability testing
  - SST acceptance criteria
  - Qualification protocols
  - Protocol execution
  - Summary
- CALIBRATION RECORDS
  - Introduction
  - Calibration and performance checks
  - Precision and accuracy
  - GLP identification rules
  - Scope of calibration
  - Calibration rules
  - Schedules
  - Calibration records
- LABORATORY SOFTWARE QUALIFICATION
  - Introduction
  - Classes of software
  - Software qualification rules
  - Software examples
  - Qualifying spreadsheets
- CHROMATOGRAPHIC SYSTEMS

- Introduction
- GC
- Typical specifications
- Column maintenance
- Mobile phase
- SST
- SPECTROPHOTOMETRIC SYSTEMS
  - Introduction
  - Types of systems
  - Operation principles
  - Typical specifications
  - Cell specifications
  - Calibration tasks I
  - Calibration tasks II
- DISSOLUTION APPARATUS
  - Introduction
  - Dissolution apparatus
  - Performance parameters
  - Typical specifications
  - Calibration tasks
- INSTRUMENT LOGBOOKS AND EQUIPMENT HISTORY
  - Introduction
  - Purpose
  - What to record

## L07-Cooling Water Treatment Technology

### **Objective:**

Cooling water systems is one of the essential parts in any field especially in both oil and gas operation fields. There are many problems in any cooling water systems (changed as water sources is changed) due to one of the following reasons: fouling, corrosion, scale formation and biological effect (SRB's& iron bacteria).

Any of the previous problems is considered a huge problem for any oil or gas cooling water systems. It is impossible to stop or eliminate the effect of the previous problems but it may be controlled and minimized using water pretreatment and addition of some chemical additives.

There are many chemical additives used in any cooling water systems like: Corrosion inhibitors, Scale inhibitors, Antifouling and biocide. Each one of the previous chemical has its own characteristics and the mechanism of action. So, it is essential to understand the principles and the effect of each chemical in oil and gas operation fields.

The goal of this course is to provide participants with an overview of the theoretical and practical aspects of cooling water principles, water sources and mode of action for all said chemical additives.

### **Who Should Attend:**

This subject will be very useful for any oil and gas fields workers how deal with cooling water systems and their chemicals additives.

The course is invoke some chemical expressions and information that attendance should be familiars with before attend this course. It is preferable that the attendance be **any workers** with little or without experience in cooling water systems treatment and cleaning procedures.

### **Course Outlines:**

The break down schedule and topics are:

- Introduction to cooling water theory and mechanism.
- Water sources and specifications.
- Problems associated with water flow in cooling systems.

- Pretreatment for cooling water.
- Different types of chemical additives used in cooling systems.
- Corrosion inhibitor types and mode of action.
- Introduction to Microbiological effect theory and mechanism.
- Biocide types and mode of action.
- Introduction to scale formation theory and ions recombination calculations.
- Scale Inhibitor types and mode of action.
- Antifouling types and mode of actions.
- Case studies.

## L08-Atomic Absorption Spectroscopy (AAS)

### **Objective:**

One of the most recent techniques for different metals analysis in any liquids is Atomic Absorption Spectroscopy. This technique is the easiest way to determine metals which are usually involved and associated with the most common process facilities (such as : formation water, cooling water, water flood & injection system, boilers water, glycol dehydration and amine sweetening). The metals concentration affects the operating condition and the productivity of the oilfields.

We have to determine all metals concentration in oilfields fluids to avoid its bad side effects, which give us an indication about corrosion rate in side pipes, scale formation tendency which could cause a serious problems to the production operations, i.e. pipe lines failure, plugging, ..., etc. We have to know different types of atomic absorption techniques by which we can determine metals concentrations like Atomic Absorption, Atomic Emission, GTA, .... Etc.

### **Who Should Attend:**

This subject will be very useful for all chemical laboratories members that metals determination is involved in their analysis jobs. The course is invoke some chemical expressions and information that attendance should be familiars with before attend this course. It is preferable that the attendance be a chemist, chemical engineer or lab technician with some experience in AAS. Also good level in English language is recommended since all materials and expressions will be in English.

### **Course Outlines:**

The break down schedule and topics are:

- AAS characteristics.
- AAS basic theory.
- Bears Lambert low and its deviation.
- Factors affecting metals absorption.
  - AAS main components (by the assistance of Videos):
- Light source.

- Atomizer.
- Optical System
- Mono-chromators.
- Detectors.
- Graphite Tube Atomizer (GTA).
- System Maintenance and Safety.
- Computer software application for AAS.

## L09-Boilers Water Treatment

### **I- Objective:**

Boilers are one of the essential equipment in any field oil, gas and petrochemical operation fields. There are many problems in any cooling water systems (changed as water sources is changed) due to one of the following reasons: fouling, corrosion, scale formation and biological effect (SRB's& iron bacteria).

Any of the previous problems is considered a huge problem for any oil or gas cooling water systems. It is impossible to stop or eliminate the effect of the previous problems but it may be controlled and minimized using water pretreatment and addition of some chemical additives.

There are many chemical additives used in any cooling water systems like: Corrosion inhibitors, Scale inhibitors, Antifouling and biocide. Each one of the previous chemical has its own characteristics and the mechanism of action. So, it is essential to understand the principles and the effect of each chemical in oil and gas operation fields.

The goal of this course is to provide participants with an overview of the theoretical and practical aspects of cooling water principles, water sources and mode of action for all said chemical additives.

### **Who Should Attend:**

This subject will be very useful for any oil and gas fields workers how deal with cooling water systems and their chemicals additives.

The course is invoke some chemical expressions and information that attendance should be familiars with before attend this course. It is preferable that the attendance be any workers with little or without experience in cooling water systems treatment and cleaning procedures.

### **Course Outlines:**

The break down schedule and topics are:

- Fundamentals of industrial boilers and impact of water quality on operation.
- Water sources and allowed levels of impurities.
- Problems associated with water flow in boilers systems.

- Causes of scale in boilers and preventive process.
- Causes of corrosion in steam generating systems and preventive process.
- Oxygen corrosion control and its monitoring.
- Different types of chemical additives used in boilers system.
- Case Studies.



## L010-Reverse Osmosis Techniques (RO)

### **Objective:**

Potable water is one of the essential parts in our life. Water sources are varied from one location to another and so the way of treatment is varied too. Water geo-chemical analysis is usually used to report the chemical composition of water constituents and to predict its behavior and tendency to form scale or to predict the presence of any microbiology.

### **Who Should Attend:**

This subject will be very useful for all chemical laboratories members that potable water is involved in their analysis jobs.

The course is invoke some chemical expressions and information that attendance should be familiars with before attend this course. It is preferable that the attendance be a ***chemist, chemical engineer or lab technician*** with some experience in water analysis procedures and methods. Also good level in English language is recommended since all materials and expressions will be in English.

### **Course Outlines:**

The break down schedule and topics are:

- Introduction to the water chemistry and fundamentals of water analysis.
- Oilfield water sampling and physical properties determination.
- Water quantitative analysis techniques.
- Volumetric and Gravimetric analysis.
  - Summary of water cations and anions analysis.
  - Review for Hypothetical salts combination.
  - Water treatment procedures.
- RO systems technology.
- EDR systems technology.
- Comparison between RO and EDR systems.
- Case Study.

## L11-Cooling Water Treatment Technology

### **Objective:**

Cooling water systems is one of the essential part in any field specially in both oil and gas operation fields. There are many problems in any cooling water systems (changed as water sources is changed) due to one of the following reasons: fouling, corrosion, scale formation and biological effect (SRB's& iron bacteria).

Any of the previous problems is considered a huge problem for any oil or gas cooling water systems. It is impossible to stop or eliminate the effect of the previous problems but it may be controlled and minimized using water pretreatment and addition of some chemical additives.

There are many chemical additives used in any cooling water systems like: Corrosion inhibitors, Scale inhibitors, Antifouling and biocide. Each one of the previous chemical has its own characteristics and the mechanism of action. So, it is essential to understand the principles and the effect of each chemical in oil and gas operation fields.

The goal of this course is to provide participants with an overview of the theoretical and practical aspects of cooling water principles, water sources and mode of action for all said chemical additives.

### **Who Should Attend:**

This subject will be very useful for any oil and gas fields workers how deal with cooling water systems and their chemicals additives. The course is invoke some chemical expressions and information that attendance should be familiars with before attend this course. It is preferable that the attendance be any workers with little or without experience in cooling water systems treatment and cleaning procedures.

### **Course Outlines**

The break down schedule and topics are:

- Introduction to cooling water theory and mechanism.
- Water sources and specifications.
- Problems associated with water flow in cooling systems.
- Pretreatment for cooling water.

- Different types of chemical additives used in cooling systems.
- Corrosion inhibitor types and mode of action.
- Introduction to Microbiological effect theory and mechanism.
- Biocide types and mode of action.
- Introduction to scale formation theory and ions recombination calculations.
- Scale Inhibitor types and mode of action.
- Antifouling types and mode of actions.
- Case studies.

## L12-Advanced Course in Corrosion Control in Oil, Gas and Petrochemicals Production fields

### **Objective:**

Corrosion is representing a big problem for oil and gas fields. It is impossible to stop corrosion but it may be controlled and minimized using some techniques and precautions. In oil and gas fields, it is very important to control corrosion the production process is contentious and the plant invariability is very expensive and the effect of uncontrolled corrosion can be imagined not only to the production but also to human and environment pollution .The cost of corrosion control is negligible relative to corrosion expenses.

Corrosion can change rapidly with the small flocculation of plant conditions and therefore corrosion pattern is complex. So, it is essential to understand the principles and the causes of corrosion in oil and gas fields.

The goal of this course is to provide participants with an overview of the theoretical and practical aspects of corrosion control in the oil and gas production industry. The course will cover the corrosion reasons and the methods by which corrosion can be identified, monitored and controlled.

Corrosion inhibitor is one of the traditional techniques to control corrosion. The course will cover the methods of corrosion inhibitors selection, testing and evaluations. Also course will explain in details all corrosion monitoring techniques that are commonly used.

### **Who Should Attend:**

This subject will be very useful for all oil and gas field inspection members how deal with corrosion and corrosion control.The course is invoke some chemical expressions and information that attendance should be familiars with before attend this course. It is preferable that the attendance be **any workers** with little or without experience in corrosion methods and monitoring procedures.

### **Course Outlines**

The break down schedule and topics are:

- Introduction to Corrosion theory and mechanism.
- Polarization and Passivation phenomena.
- Environmental effect on Corrosion.

- Eight forms of corrosion (mechanisms, material subjected, environments promotes each and control of each form).
- Material selection and design consideration to minimize the corrosion rates.
- Corrosion control by Corrosion inhibitors.
- Corrosion inhibitors selection and evaluation.
- Corrosion control by Cathodic protection.
- Corrosion monitoring techniques.
- Case study.

# L13-Corrosion Control and Monitoring fundamentals for Technicians

## **Objective:**

Corrosion is considered a very huge problem especially for oil, gas and petrochemical facilities technicians who deal with corrosion. The corrosion can be controlled very well with many types of techniques. The cost of this control is negligible relative to corrosion expenses.

The goal of this course is to provide participants from technicians with an overview of the theoretical and practical aspects of corrosion and corrosion control especially in the oil, gas and petrochemical production industries. The course will cover the corrosion reasons and the methods by which corrosion can be identified, monitored and controlled.

Many traditional techniques are used nowadays to control corrosion. One of the most traditional techniques to control corrosion is the usage of corrosion inhibitor. The course will cover the methods of corrosion inhibitors selection, testing and evaluations. Also course will touch the most of monitoring techniques.

## **Who Should Attend:**

This subject will be very useful for all oil and gas fields technician members how deal with corrosion and corrosion control.

The course is will be very useful for all field technicians with little or high experience in corrosion and corrosion control.

## **Course Outlines**

The break down schedule and topics are:

- Introduction to Corrosion theory and mechanism.
- Environmental effect on Corrosion.
- Forms of Corrosion.
- Corrosion control by Corrosion inhibitors.
- Corrosion inhibitors selection and evaluation.
- Corrosion control using other techniques (Cathodic Protection, Anodic Protection,...etc).
- Corrosion monitoring techniques.
- Case study.

## **Q-Quality Assurance and Quality Control**

Q01- Introduction to Six Sigma

Q02-Continual Improvement Assessment (CIA) using Lean thinking and Six Sigma methodologies

Q03-Statistical Process Control (SPC)

Q04-Integrated Management systems (IMS)

Q05-Introduction to Quality Engineering

Q06-Root Cause Analysis

Q07-CertifiedQuality Auditor (CQA)

## **Q01-Introduction to Six Sigma**

### **Course Overview**

This overview course is designed to provide a broad understanding of the Six Sigma improvement methodology, concepts, and language. The Define-Measure-Analyze-Improve-Control methodology is presented with case studies and examples drawn from service, business process, and manufacturing applications. The integration of Lean Manufacturing and Six Sigma is also addressed. With a heavy practice orientation, as much as a third of your time will be spent working through interactive practice exercises and online assessments.

### **Learning Objective**

- Understand the benefits and implications of a Six Sigma program, and relate Six Sigma concepts to the overall business mission and objectives
- Think about your organization as a collection of processes, with inputs that determine the output
- Use the concept of a Sigma Level to evaluate the capability of a process or organization
- Recognize the five-step D-M-A-I-C model used to improve processes
- Recognize the organizational factors that are necessary groundwork for a successful Six Sigma program
- Integrate a Six Sigma effort with other process improvement initiatives, including Lean Enterprise (Lean Manufacturing).

### **Who Should Attend**

CEOs, directors, senior managers, quality control engineers and those who are responsible for evaluating or implementing Six Sigma.

### **How will I benefit?**

- Understand what Lean Six Sigma is and how it can impact your business



- Put into place your own Six Sigma framework and gain competitive advantage
- Make cost savings through streamlined processes
- Improve time and performance management
- Increase customer satisfaction and loyalty
- Share knowledge and motivate employees.

## **Course Outlines**

### • Introduction to Lean Six Sigma

- What is Lean Six Sigma?
- Where did it originate?
- Why is it so effective and popular?

### • Lean Six Sigma Roles

### • The 8 Wastes

- Defects
- Overproduction
- Waiting
- Non-Utilized Employees
- Transportation
- Inventory
- Motion
- Extra Processing

### • **DMAIC Overview**

#### ○ **Define Phase – How to define the problem.**

- Project Charter (Tool)
- Defining Value: Voice Of the Customer (VOC) (Tool)
- High Level Process Map: SIPOC (Tool)

#### **Measure Phase – How to measure the current process.**

- Selecting Measures
- Data Collection Planning
- Operational Definitions
- Capturing Baseline Data

#### **Analyze Phase – How to identify the cause of the problem.**

- Process Analysis
- The Five Whys and The Fishbone Diagram (Tool)

- Pareto Charts (Tool)
- Develop a Hypothesis

**Improve Phase – How to implement and verify the solution.**

- Optimize Flow
- Mistake-Proofing: Poka-Yoke (Tool)
- Visual Management and 5S

**Control Phase – How to maintain the solution.**

- Process Control Plan (*Tool*)
- Monitoring and Response Plan (*Tool*)
- Documentation and Storyboard

## **Q02-Continual Improvement Assessment (CIA) using Lean thinking and Six Sigma methodologies**

### **Course Overview**

This overview course is designed to provide a broad understanding of the implementation of lean thinking and six sigma methodologies in the continual improvement assessment (CIA). The Define-Measure-Analyze-Improve-Control methodology is presented with case studies and examples drawn from service, business process, and manufacturing applications. The course will help you: understand the fundamentals in achieving maximum customer satisfaction at the lowest overall cost, focus on delivering a quality product or service by improving your processes, or set up a world-class quality management system

### **Learning Objective**

- Explain continual improvement to others.
- Identify continual improvement actions.
- Plan continual improvement assessments.
- Collect continual improvement audit evidence.
- Contrast necessary, value added, and superficial types of improvement.
- Distinguish between containment, corrective, preventive, and innovative improvement actions.
- Appraise processes using process performance indicators.
- Recognize process inefficiencies, risks, and opportunities.
- Compare results to scorecard objectives.
- Use data to report leading indicators.
- Calculate the effect of findings on wealth (F/P matrix).
- Understand management COR interests.
- Assess gaps in the organization management system.
- Conduct self-assessment perception surveys and analyze results.
- Implement a continual improvement assessment (CIA) program.

## **Who Should Attend**

CEOs, directors, senior managers, quality control engineers and those who are responsible for implementing a continual improvement assessment (CIA) program.

## **Course Outlines**

- I. Why Check Continual Improvement
  - a. Highly Desirable and Beneficial
  - b. What Is Continual Improvement
- II. Continual Improvement Assessment Planning
  - a. Purpose
  - b. Strategies
  - c. Planning
- III. Verifying Continual Improvement: Preparing
  - a. The Key Characteristic of Continual Improvement
  - b. Required Continual Improvement (Conformance or Compliance)
  - c. Continual Improvement Test
  - d. Continual Improvement Verification Audit Plan
- IV. Verifying Continual Improvement: Performing and Reporting
  - a. Performing
  - b. Analyzing and Classifying
  - c. Continual Improvement Reporting
  - d. Auditor, Assessor, Examiner Qualifications
  - e. Who and How Often
- V. Process Auditing for Continual Improvement: Preparing
  - a. Process Auditing for Improving Performance
  - b. Key Process Performance Indicators
  - c. Assessment Planning
  - d. Process Auditing for Continual Improvement: Audit Plan
- VI. Process Auditing for Continual Improvement: Performing and Reporting
  - a. Performing the Assessment
  - b. Identifying Opportunities for Improvement
  - c. Identifying Risks to the Organization
  - d. Is the Process Optimized?
  - e. Continual Improvement Reporting
  - f. Predicting Performance
  - g. Assessor Qualifications
- VII. Reporting Performance and Wealth
  - a. Link to Customer Interests
  - b. Management Thinking
  - c. Finding and Pain
- VIII. Assessment for Performance Improvement Gaps
  - a. Criteria

- b. Purpose
  - c. Scope
  - d. Assessment Team
  - e. Authority/Permission
  - f. Audit Plan
  - g. Conducting the Assessment
  - h. Reporting
- IX. Self-Assessment Perception Survey
- a. Quality Management Principles
  - b. Results – Analysis
  - c. Supplier Relations
  - d. Organization Objectives
  - e. Implementation
  - f. Conclusion
- X. Managing the Continual Improvement Assessment Program
- a. Need
  - b. Preparing
  - c. Program Scope
  - d. Responsibilities and Qualifications
  - e. Program Guidelines
  - f. Performing
  - g. Measuring and Monitoring the Service
  - h. Implementation of the Continual Improvement Assessment Process
  - i. Organization Score-keeping

## **Q03-Statistical Process Control (SPC)**

### **Course Overview**

This course provides an introduction to basic concepts for charting process behavior using statistical process control charts. The content covered by this course is also known as Statistical Process Control (SPC). Participants will receive a basic understanding of tools and methods used to measure and understand process behavior over time - in support of a Six Sigma DMAIC project or for ongoing process management.

Course materials are presented within the context of a Six Sigma improvement project, where process behavior charts (control charts) are often used in the Measure, Analyze, and Control phases of the D-M-A-I-C process. However, involvement in a Six Sigma project is not a prerequisite, and no prior knowledge of Six Sigma is assumed. This course is a component of the Online Six Sigma Black Belt and Online Six Sigma Green Belt courses.

### **Learning Objective**

- Understand the Six Sigma DMAIC process
- Understand the basics of measurement
- Construct and interpret a histogram
- Evaluate process performance over time using a Trend Chart
- Develop a subgrouping strategy
- Construct and interpret Statistical Process Control charts for variable and attribute data
- Perform a capability analysis
- Recognize when to apply the tools and techniques to complete the measure, analyze, or control phase of a Six Sigma project
- Perform calculations as required.
- Conduct self-assessment perception surveys and analyze results.
- Implement a continual improvement assessment (CIA) program.

### **Who Should Attend**

CEOs, directors, senior managers, supervisors, quality control engineers, scientists.

### **Course Outlines**

- Measurement & Metrics
- Trend Chart Toolset
- Histogram Toolset
- Quantifying Process Variability
- SPC - Introduction and Background
- SPC - Introduction to Control Charts
- SPC - Control Chart Limits
- SPC - More On Control Limits
- Implementing SPC
- SPC Chart Selection
- Rational Subgrouping Toolset
- X and Moving Range Charts - Toolset
- Attribute Control Chart Toolset
- X-bar and R Chart Toolset
- Related Theory
- Process Capability Toolset
- Advanced SPC Charts I
- Advanced SPC Charts II
- Exercises and Quiz

## Q04-Integrated Management systems (IMS)

### Course Overview

Quality management just makes sense. You need to know how to make it a part of your organization. In this course, you'll review advanced quality management principles, best practice techniques, tools, and skills. You'll find these concepts useful in a wide range of businesses and organizations including manufacturing, service, government, education, and healthcare. The course uses adult learning principles including Discovery Learning techniques, small group work, self-assessments, articles, and mini-case study reviews. You will create a list of key areas for improvement and develop a draft action plan that you can finalize back on the job.

### Learning Objective

- Apply QM concepts and practices to create workplace value
- Utilize a course overview roadmap to understand the integration of each module and the "big picture"
- Make use of the ASQ Futures Study to see and understand the impact of change on their business and the changing roles of quality professionals
- Compare and contrast the use of business excellence models and standards as a key management tool; understand the goals of quality management that support business excellence
- Apply the best practices in culture, leadership, and change management to assure adequate consideration is given to key human factors needed to achieve technical solutions
- Be able to understand the evolution of business metrics and today's use of metrics to align with and deploy business strategy
- Familiarize themselves with the framework of a Balanced Scorecard, and use the Baldrige Criteria and the BSC Hall of Fame criteria to critique their organization's process.
- Recognize elements of best practice customer listening posts and the strategic use of customer value drivers to target and improve performance.



- Examine the strategic use and integration of improvement methods such as cost of Quality, Six Sigma, Lean Six Sigma, and benchmarking.

## **Who Should Attend**

Quality managers and directors, small business CEOs and COOs, division and department managers, general managers, finance directors, military officers, and anyone who is responsible for implementing and integrating quality management practices into their organizations..

## **Course Outlines**

- I. **Quality Management Overview**
  - A. What is it?
  - B. Business excellence models and standards, tools of management
  - C. Process management
- II. **Human Factors Needed to Achieve Technical Solutions**
  - A. HR performance management
  - B. Culture and leadership
  - C. Change management
- III. **Performance Metrics and Strategic Planning for Improvement**
  - A. Performance metrics evolution; BSC
  - B. Customer listening posts and the strategic use of customer value drivers to target and improve performance
  - C. Strategic use and integration of improvement methods such as COQ, Six Sigma, Lean Six Sigma, and benchmarking
- IV. **Product & Service Design and Improvement**
  - A. Juran Trilogy and exemplary model and methods for product/service planning (design and development) and improvement
  - B. Similarities and differences between current methods such as QFD, DFSS, APQP, DOE, FMEA, control plans, Lean, Six Sigma, Lean Six Sigma (LSS)

## **Q05-Introduction to Quality Engineering**

### **Course Overview**

Participants will learn about Quality Engineering concepts and tools such as quality systems, auditing, product and process control and design, quality methods and tools, applied statistics, SPC, and Design of Experiments (DOE). Enhance your engineering expertise and your effectiveness as a Quality Engineer with this comprehensive introduction to key quality engineering concepts and tools critical to success in the field of Quality Engineering today. Please note that, while this course addresses many areas of the body of knowledge for the Certified Quality Engineer examination.

### **Learning Objective**

- Understand basic quality management principles.
- Understand the relationship of the quality engineer to the quality system.
- Analyze the relationship of statistics to a process.
- Understand process capability and use statistical process control to monitor a process.
- Generate acceptance sampling plans and identify and use technical quality tools.
- Incorporate quality technology in design, customer-supplier relationships, Reliability, Availability, and Maintainability (RAM), materials control, measurement, auditing, quality costs and document control within a quality system.
- Apply problem-solving tools and basic statistical concepts, process control and process capability plans, acceptance sampling, and attribute controls.

### **Who Should Attend**

Engineers, quality control personnel, inspectors, testing personnel, or those interested in the quality engineering profession.

## **Course Outlines**

- I. **Overview of Management and Leadership Principles**
  - A. Quality Philosophies and Foundations
  - B. The Quality Management System (QMS)
    - 1. Strategic planning
    - 2. Deployment techniques
    - 3. Quality information system (QIS)
  - C. Facilitation Principles and Techniques
  - D. Customer Relations
  - E. Supplier Management
- II. **The Quality System**
  - A. Elements of the Quality System
  - B. Documentation of the Quality System
  - C. Quality Standards and Other Guidelines
  - D. Quality Audits
    - 1. Types of audits
    - 2. Roles and responsibilities in audits
    - 3. Audit planning and implementation
    - 4. Audit reporting and follow up
  - E. Cost of Quality (COQ)
  - F. Quality Training
- III. **Product and Process Design**
  - A. Classification of Quality Characteristics
  - B. Design Inputs and Review
  - C. Reliability and Maintainability
    - 1. Reliability and maintainability indices
    - 2. Reliability / Safety / Hazard Assessment Tools
- IV. **Product and Process Control**
  - A. Tools
  - B. Material Control
    - 1. Material identification, status, and traceability
    - 2. Material segregation
    - 3. Classification of defects
    - 4. Material review board (MRB)
  - C. Acceptance Sampling
    - 1. Sampling concepts
    - 2. Sampling standards and plans; sampling integrity
  - D. Measurement System Analysis (MSA) and Metrology
- V. **Continuous Improvement**
  - A. Quality Control Tools
  - B. Quality Management and Planning Tools
  - C. Continuous Improvement Techniques
  - D. Corrective Action
  - E. Preventive Action
- VI. **Quantitative Methods and Tools**

- a. Collecting and Summarizing Data
  - Descriptive statistics
  - Graphical methods for depicting relationships
  - Graphical methods for depicting distributions
- b. Quantitative Concepts: Terminology
- c. Probability Distributions
  - Continuous distributions
  - Discrete distributions
- d. Statistical Decision-Making
  - Point estimates and confidence intervals
  - Hypothesis testing
  - Paired-comparison tests
  - Goodness-of-fit tests
  - Contingency tables
- e. Relationships Between Variables
  - Linear regression
  - Simple linear correlation
- f. Statistical Process Control (SPC)
  - Objectives and benefits
  - Common and special causes
  - Selection of variable
  - Rational subgrouping
  - Control charts
  - Control chart analysis
  - Short-run SPC
- g. Process and Performance Capability
  - Process capability studies
  - Process performance vs. specifications
  - Process capability indices
  - Process performance indices
- h. Design and Analysis of Experiments
  - Terminology
  - ANOVA
  - Planning and organizing experiments
  - One-factor experiments
  - Full-factorial experiments
  - Two-level fractional factorial experiments

**Course Summary; Concluding Activities**

## Q06-Root Cause Analysis

### Course Overview

This course will enable participants to understand root cause analysis as a procedure for ascertaining and analyzing the causes of problems in an effort to determine what can be done to solve or prevent them. Consisting of lectures, practice, and role-playing, this course is designed to provide attendees with an in-depth understanding of how to analyze a system to identify the root causes of problems.

### Learning Objective

- Enhance problem solving effectiveness by providing a model for more deeply analyzing problem situations.
- Clarify the difference between analytical and creative thinking, and when each is most useful.
- Promote the ability to provide problem-solving support in situations where one is not an expert in the process or technology involved.
- Expand the range of tools available for analysis of problem situations.

### Who Should Attend

Quality, safety, risk, and reliability managers, process engineers, technicians, operations supervisors and personnel, process owners, occurrence investigators, analysts, maintenance directors, reliability professionals, and anyone who wants to improve their ability to solve recurring problems should attend this training. Manufacturing markets include core manufacturing markets in machinery and computer equipment, chemical and allied products, fabricated metals, electronics, transportation, and measurement/controlling industries. Service markets that could effectively leverage this course would include consulting/business services, financial services, wholesale/retail, transportation, utilities, and government.

### Course Outlines

- I. TYPICAL PROBLEMS WITH RCA

- A. Why most problem solving models don't get to the root cause, and a solution
- B. How analytical and creative thinking must be both separated and integrated
- C. Difference between content and process thinking
- II. STEP 1 – PROBLEM DEFINITION
  - A. How to ensure that the right problem is being worked on
  - B. Tools and filters for priority setting
  - C. Developing a clear and sufficient problem statement (includes practice)
- III. STEP 2 – UNDERSTANDING THE PROCESS
  - A. How every problem is a process failure
  - B. How a SIPOC diagram can set boundaries and define interrelationships
  - C. Using flowcharts to drill down into the right part of the process (includes practice)
- IV. STEP 3 – IDENTIFYING POSSIBLE CAUSES
  - A. Five ways to identify possible causes
  - B. Three options for selecting or eliminating causes
  - C. Logic trees as a cause and effect diagram on steroids (includes practice)
- V. STEP 4 – DATA COLLECTION
  - A. Population versus sampling; options for sampling
  - B. Check sheets, graphs, and tables for discrete data collection
  - C. Surveys, interviews, and field observation for opinions or less precise data
- VI. STEP 5 – DATA ANALYSIS
  - A. Tools for discrete data analysis (run charts, histograms, pareto diagram, modified scatter diagram, pivot tables)
  - B. Tools for softer type data (affinity diagram, relationship digraph)
  - C. Integrative data analysis tools
- VII. CONSULTING CASE STUDY PRACTICE
  - A. Participants role play consulting with instructor on a problem
  - B. Review of key learning points
- VIII. INCIDENTS/EVENTS AND HUMAN ERROR
  - A. How incident/accident analysis differs
  - B. Causes of and solutions for human error
- IX. CASE STUDY PRACTICE
  - A. Practice on a project relevant to participants' organization
- X. FACILITATION SKILLS
  - A. Process facilitation versus content expert
  - B. Facilitation roles and intervention choices
- XI. CASE STUDY PRACTICE – Practice on an integrative problem
- XII. THE REST OF THE PROBLEM SOLVING PROCESS
  - A. Identifying and selecting solutions
  - B. The importance of organizational change management issues
  - C. Some models for understanding resistance and planning change
  - D. Implementation, follow-up, and standardization
- XIII. MANAGEMENT/ORGANIZATIONAL ISSUES AFFECTING RCA PROJECTS
  - A. Cognitive biases that affect RCA
  - B. Impact of organizational culture
  - C. Structures/roles that can support RCA
- XIV. STATISTICAL HYPOTHESIS TESTING AND MS EXCEL
  - A. What t, F, and ANOVA tests can do
  - B. How to do them in MS Excel
  - C. Using chi-square for count data

XV. DRILLING DOWN WITH DATA

- A. Seeing variation as a 3+ dimensional space
- B. How to slice major components of that variation
- C. Which tools to use for data comparisons

## Q07-Certified Quality Auditor (CQA)

### Course Overview

This course is designed to provide quality practitioners, managers, professionals, auditors, and improvement team members with an understanding of basic quality tools and techniques, and covers Part V (Quality Tools and Techniques) of the CQA Body of Knowledge (BOK). It is intended for those interested in conducting quality system audits using any performance standard (ISO 9001, FDA GMPs, FAA, QS 9000, etc.). Attendees will learn content through a series of lessons, illustrations, diagrams, interactive exercises, quizzes, tests, and a problem-solving team case study that students must review and be tested on to pass the class.

### Learning Objective

- Identify the steps needed to prepare for an audit.
- Use general audit terminology.
- Identify types of data used as evidence.
- Conduct the steps for performing an audit.
- Use working papers such as checklists.
- Determine when a practice or situation represents a nonconformance or finding.
- Determine methods to analyze and classify nonconformities or findings.
- Report results of an audit.
- Verify corrective action of audit findings.
- Close out audit findings.
- Demonstrate linkages between reporting and follow-up to ensure there was action.
- Integrate process auditing practices and auditing process-based management systems into auditing conventions.

### Who Should Attend



This course is suited to quality practitioners, managers, professionals, auditors, and improvement team members with an understanding of basic quality tools and techniques. It may be used for professional development.

## **Course Outlines**

- Overview of an Audit
- Audit Initiation, Purpose, Scope, and Resources Required
- . Audit Preparation and Planning
- a. Defining the Audit
- Authority, Standards, Understanding and Communicating
- . Sources of Authority
- a. Identify Requirements
- b. Flowcharting Processes
- Evaluate Documents, Prepare Checklists, Determine Audit Strategy
- . Meeting Quality System Requirements
- a. Prepare Working Papers
- Opening Meetings, Briefings, and Working Papers
- . Auditor Responsibility
- a. Method and Techniques
- Data Analysis
- . Collection Plan
- a. Document and Record Examination
- b. Techniques for Controls without Written Procedures
- Audit Analysis
- . Classification of Observations
- a. Audit Conclusions
- Exit Meeting
- . Team Member Roles
- a. Setting Agendas
- Audit Reporting
- . Definition of Terms
- a. Report Format
- b. Confidentiality Issues
- Audit Follow Up and Closure
- . Corrective Action and Preventive Action Process
- a. Review Criteria
- b. Verification Methods

## **S-Safety course**

- S01- Risk Assessment Techniques "HAZOP & HAZAN"
- S02- Loss Prevention
- S03- Risk Management
- S04- HSE Management System
- S05- Management of Hazardous Materials
- S06-Hazardous Area Classification
- S07-Emergency Plane & Response
- S08-Accident Investigation
- S09- Fires from First principles
- S10- Safety Auditing
- S11- Electrical Safety
- S12- Environmental Impact Assessment
- S13-Fire theory, protection and control
- S14- HAZMAT managing of chemical releases
- S15- Loss Prevention Leadership
- S16- Corrosion Problems and their Solving in Firefighting Loops
- S17-برنامج الامان و السلامه فى عمليات الرفع-
- S18- Safety at Laboratories
- S19- Safety At Workshops (Hand and Portable Power tools)
- S20-السلامه فى اعمال قطع و اللحام و الثقب على الساخن-
- S21- Safety Of Portable ladders and scaffoldings
- S22- Job Hazard Analysis & Risk Calculation
- S23-القياده الامنه و سلامه اوناش الشوكه-

S24- Fire Fighting Pumps Theory, Construction, Operation and Maintenance

S25- Integrated Management Systems (IMS) for Safety Specialists

# **S01-Risk Assessment Techniques**

## **"HAZOP & HAZAN"**

### **Objectives:**

The attendants should know the process hazards, and the different methods used to identify, evaluate, and assess the industrial risks.

### **Who Should Attend:**

Safety engineers, process engineers, maintenance engineers, as well as all management levels.

### **Duration:**

5 days

### **Course Outline:**

Introduction to risk assessment.

Process hazards

The concept of risk

Identifying process hazards

Check - lists

Fire Indices

HAZOP

Process hazards analysis

Failure modes, effects, and analysis

Fault tree analysis

Event tree analysis

Protective systems

## **S02- Loss Prevention**

### **Objectives:**

The attendants should learn most of safety aspects that is related to the workplace and environment.

### **Who Should Attend:**

All new employees who are working in the industrial, petroleum, and petrochemicals plants

### **Duration:**

5 days

### **Course Outline:**

- Introduction to safety
- Science of engineering safety
- Work permits
- Fire precautions
- Safe use of machinery; and electricity
- Safety at construction site
- Managing chemicals safely

### **N.B.:**

**This course is available with Arabic language for technicians  
( if required)**

## **S03-Risk Management**

### **Objectives:**

The attendants should know the concept of risk management, and how to evaluate and manage all kinds of risks that is related to the workplace and projects environment.

### **Who Should Attend:**

The personnel who have attend the basic course of risk assessment techniques.

### **Duration:**

5 days

### **Course Outline:**

- Introduction to risk management
- The concept of risk management
- Projects and risk
- Risk scoring and evaluation
- Human aspects
- Reliability
- Soft system methodology
- Risk allocation
- Review of risk assessment techniques
- Case study.

## S04-HSE Management System

### **Objectives:**

This course is to understand OHSAS 112001 standard and specifications.

### **Who Should Attend:**

Safety engineers, process engineers, maintenance engineers, as well as all management levels.

### **Duration:**

5 days

### **Course Outline:**

- Introduction to OHSAS 112001
- Definitions
- Correlation between OHSAS 112001 and ISO 14001
- Occupational Health and Safety Management Systems
- Loss Causation and Control
- OHSAS 112001 structure and implementation

## S05-Management of Hazardous Materials

### الغرض من البرنامج:

الغرض من البرنامج هو التعرف على مفهوم الصحة المهنية بالنسبة للأمن الصناعي وتأثير ذلك على العاملين مع زيادة الوعي تجاه المخاطر الناجمة عن تداول المواد الكيماوية ودرجة خطورتها وكذلك المخاطر الناجمة عن الحرائق وسبل التعامل معها.

### المؤهل لحضور البرنامج:

مهندسين, كيميائيين وفنيين التشغيل فى مصانع البترول والبتروكيماويات

### مدة البرنامج:

خمسة أيام

### محتويات البرنامج:

- 1 - تعريف الصحة المهنية وعلاقتها بالأمن الصناعي
- 2 - التغذية في الصناعة.
- 3 - الأمراض المهنية ومدى تأثيرها على الفرد العامل
- 4 - المواد الكيماوية ومخاطرها
- 5 - سبل تداول المواد الكيماوية الخطرة.
- 6 - الحرائق وأنواعها
- 7 - كيفية مكافحة الحرائق



## **S06-Hazardous Area Classification**

### **Objectives:**

The Course is aimed to clarify the criteria upon which the classification and designation of certain location and the methods followed to select the suitable apparatus for use in certain location.

### **Who Should Attend:**

Safety engineers, process engineers, maintenance engineers, as well as all management levels.

### **Duration:**

5 days

### **Course Outline:**

- 1- Introduction
- 2- Hazardous Area Classification Definitions
- 3- Codes and Standards of Equipment
- 4- Methods of Protection
- 5- Hazardous Area Classification Design
  - API Code
  - IP Code
- 6- Electrical Design Safety
- 7- Equipment Certification

## **S07-Emergency Plane & Response**

### **Objective:**

This course clarifies the stepwise procedure for constructing, establishing, and execution of emergency plans for all hazards giving a closer approach in to disaster management.

### **Who Should Attend :**

Process engineers that involved in emergency plans, General Managers and mid managers, EHS managers & specialists, and any other personnel that involved in a contingency plan.

### **Duration:**

5 days

### **Course Outline:**

1. Introduction to the emergency management.
2. Guide for the establishment of an emergency plan.
3. Planning process
4. Emergency management considerations
5. Hazard specific information
6. Emergency operations plan format.
7. Basic plan content
8. Techniques for emergency plan
9. Case study
10. Emergency control on off shore
11. Disaster supplies kit.

## **S08-Accident Investigation**

### **Objectives:**

This course is aimed to acknowledge accident investigation teams with the proper methods to conduct an accurate and precise accident investigation.

### **Who should attend:**

All personnel who are related to the process of accident investigation.

### **Course duration:**

5 days (20 Hr.)

### **Course contents:**

- 1- Definitions
- 2- Types of investigation and analysis
- 3- Cases to be investigated
- 4- Accident investigation
- 5- Accident analysis
- 6- Report preparation
- 7- Estimating incident costs
- 8- Off-the-job disabling injury cost.

## **S09- Fires from First principles**

### **Objective:**

The attendants should know the fire fighting techniques and principals, as well as the proper selection of the extinguishing agents. They should know also how to prepare a fire crew, and how to maintain the fire fighting equipment.

### **Who should attend:**

Participants who are involved in fire fighting.

### **Duration:**

5 days

### **Course Outline:**

1. Basic fire fighting concepts
2. Extinguishing agents.
3. Using fire extinguisher
4. Foam and foam equipment
5. Fighting petroleum fires.
6. Preparing fir crew for industrial plants
7. Real world fire cases
8. Fire fighting equipment

## **S10-Safety Auditing**

### **Objectives:**

This course has been developed to help managers and supervisors acquire new techniques and improved skills, which will enable them to satisfy the safety responsibilities of their work.

### **Who should attend:**

All Personnel who are working in the industrial, petroleum and petrochemical plants .

### **Duration:**

5 days

### **Course Outline:**

- Auditing
- Auditing Program
  - Purpose
  - Principles
  - Audit Process
  - Action stages
  - Use of information
  - Benefits of advanced safety auditing
- Communication skills
- Demonstrating Management commitment
- Safety Coaching
- Accidents and unsafe acts
- Managing safety
- Advanced Safety Audit Report

## **S11-Electrical Safety**

### **Objectives:**

This course is to give a close look for the safety of electrical appliances, and the injuries that could result from them.

### **Who should attend:**

All electrical and instrumental personnel. Safety scientists.

### **Duration:**

5 days ( 20 Hr .)

### **Course Outline:**

1. Definitions
2. Electrical injuries
3. Electrical equipment
4. Grounding
5. Determining hazardous locations
6. Inspections
7. Maintenance

## **S12-Environmental Impact Assessment**

### **Objective:**

Environmental impact assessment is one of the fundamental tools normally used to promote environmentally sound decision making for development. This course enables scientists to properly assess risks and compliance issues related to specific project activities at the outset and before major resource and design decisions have already been made.

### **Who should attend:**

Planners, regulators, engineers, project sponsors, and environmental scientists.

### **Duration:**

5 days (20 Hr. )

### **Course Outline:**

- 1-Introduction
- 2- EIA and project planning
- 3- EIA methodology
- 4- Methodology review criteria
- 5- Projects Impacts on environmental Parameters
  - Air pollution
  - Water pollution
  - Noise and Vibration
- 6- Chemical and hazards risks
- 7- Natural Environment
- 8-Environmental Monitoring
- 9- Environmental Auditing
- 10- Reviewing Elias

## **S13-Fire theory, protection and control**

### **Objectives:**

This course is aimed to give some knowledge about the program of how to prevent fires from starting. This will include an overview about all the aspects related to the fire and the protection of its consequences.

### **Who should attend:**

All safety and fire fighting specialists and engineers. All other scientists that are related to the field of fire fighting.

### **Duration:**

5 days (20 Hr. )

### **Course Outline:**

- 1- Introduction to the chemistry of fire
- 2- Facility fire protection program
- 3- Fire prevention activities.
- 4- Classification of fires.
- 5- Fire risks
- 6- Fire safe building design and site planning.
- 7- Fire resistive construction
- 8- Construction methods for fire protection
- 9- Factors contributing to industrial fires.
- 10- Fire detection
- 11- Alarm systems
- 12- Fire extinguishers
- 13- Sprinklers and water spray systems
- 14- Special systems and agents.



## **S14-HAZMAT Managing of chemical releases**

### **Objective:**

The attendant should know how to identify and assess chemicals hazards. They also should know how to handle, and store the chemicals safely with the properly selected PPE. They should know how to manage any spill and /or leakage.

### **Who should attend:**

Engineers, technicians, and scientists.

### **Duration:**

5 days ( 20 Hr. )

### **Course Outline:**

- 1- What are chemicals?
- 2- What kind of hazards do chemicals do?
- 3- Safe use of flammable and combustion liquids
- 4- Safe use of dangerously reactive liquids and solids.
- 5- Safe use of oxidizing liquids and solids.
- 6- Safe use of corrosive materials.
- 7- Safe use of compressed gasses.
- 8- Safe use of toxic materials.
- 9- COSHH regulations and assessment.
- 10- MSDS of hazardous chemicals
- 11- Safety Equipment
- 12- Management of spill / leakage.

## **S15-Loss Prevention Leadership**

### **Objectives:**

This course is a help to improve the effectiveness, efficiency, and excellence of your management system for safety/ loss control. Improved quality, production and cost control go hand – in – hand with improved safety and loss control. And they all depend on how the system is managed.

### **Who should attend:**

All managers, line managers, safety scientists who are practicing safety.

### **Duration:**

5 days (20 Hr.)

### **Course contents:**

- 1- The modern evolution of safety management.
- 2- The causes and effects of loss
- 3- Management control of loss.
- 4- Accident / Incident Investigation
- 5- Planned Inspection
- 6- Task analysis and Procedures
- 7- Planned job/ task observation
- 8- Group meetings
- 9- Employee training
- 10-Property damage and waste control.

## **S16-Corrosion Problems and their Solving in Firefighting Loops**

### **Objective:**

Firefighting loops are the most important part in any company specially for oil, gas or Petrochemical fields that we cannot work without them. If any Stop happen for this firefighting loops because of any reason is representing a very big problem that we can not work with out the existence firefighting loop in good conditions.

Corrosion is one of the most important factors that affect firefighting loops specially due to the static flow for a long time with out flushing or draining for the water exist in the firefighting loops. It is impossible to stop this type of corrosion but it may be controlled and minimized using some techniques and precautions.

Corrosion pattern in firefighting loops is very complex. Because there are many factors affect this pattern specially (high salinity, dissolved oxygen, SRB's and scale tendency). So, it is essential to understand the principles and the causes of corrosion in these loops.

The goal of this course is to provide participants with an overview of the theoretical and practical aspects of corrosion control in firefighting loops in oil , gas and petrochemical production industry. The course will cover the reasons that corrosion can be caused and the methods by which corrosion can be identified, monitored and controlled.

### **How Should Attend:**

This subject will be very useful for all oil, gas and petrochemical fields workers how deal with firefighting loops problems.

The course is invoke some chemical expressions and information that attendance should be familiars with before attend this course.

It is preferable that the attendance be any workers with little or

with out experience in corrosion methods and monitoring procedures.

**Duration:**

This course will cover 20 hours distributed in five days. The first four days will be theoretical lectures and the last day will be practical exercises and applications. The break down schedule and topics are:

- Introduction to Firefighting loops and their problems.
- Factors affecting firefighting loops.
- Scale tendency control using Scale Inhibitor.
- Dissolved Oxygen effect and how to solve this problem.
- Biological corrosion effect on firefighting loops.
- Corrosion monitoring techniques.
- Case study.

## S17- برنامج الامان والسلامة فعمليات الرفع

### \*الهدف من البرنامج :

التعرف على الاحتياطات الواجب توافرها في استخدام الأوناش المختلفة وكذلك الأسس التي يتم عليها اختيار وايرات الرفع وطرق التحميل الآمنة .

### \*مدة البرنامج:

خمسة أيام

### \*محتويات البرنامج:

- 1 - الاحتياطات الواجب توافرها قبل بدء الرفع
- 2 - الاحتياطات الواجب توافرها أثناء عملية الرفع
- 3 - الإشارات العالمية لتحريك الأوناش
- 4 - الوايرات وكيفية اختيارها
- 5 - عيوب الوايرات وطرق كشفها

# **S18-Safety At Laboratories**

## **Objectives :**

This course is carried to give some knowledge about the safety at laboratories; this will include an overview about all aspects related to the safety at laboratories of its consequences.

## **Who should attend :**

Lab chemists and technicians, safety specialist and safety Forman and all others that are related to the said field.

## **Course duration:**

5 days ( 20 Hr )

## **Course contents :**

- 1- general safety principles
- 2- health hygiene
- 3- housekeeping
- 4- Chemical handling and storage.
- 5- Elec. Safety
- 6- Mercury spills
- 7- Chemical spills
- 8- Waste disposal
- 9- Hazards of compressed gases and gas cylinders at labs.

# **S19-Safety At Workshops**

## **(Hand and Portable Power tools)**

### **Objectives :**

This course is a help to improve the effectiveness, efficiency and excellence the usage of hand and portable power tools, with improved safety.

### **Who should attend :**

Workshop workers, maintenance engineers, safety specialists and Forman, who are practicing safety

### **Course duration:**

5 days ( 20 Hr )

### **Course contents :**

- 1- preventing accidents
- 2- maintenance and repair
- 3- use of hand tools and its hazards
- 4- safety precaution of hand tools
- 5- portable power tools
- 6- compressed air powered equipment
- 7- safety precaution of portable power tools
- 8- P.P.E.

## S20- السلامة في أعمال القطع و اللحام و الثقب على الساخن

### \* الهدف من البرنامج

التعريف على الاحتياطات الواجب توافرها أثناء عمليات القطع و اللحام و الثقب على الساخن و معايير السلامة المختلفة لكل عملية.

### \* الوهل لحضور البرنامج :

اللحامين ، البرادين ، رجال السلامة

### \* مدة البرنامج

خمسة ايام ( 20 ساعة )

### \* محتويات البرنامج

- 1- مقدمة وتعريف
- 2- تداول الاسطوانات
- 3- تخزين الاسطوانات
- 4- استخدام الاسطوانات
- 5- منظمات الضغط
- 6- الوقاية من الحريق
- 7- العمل في الامكان الخطرة
- 8- تعريف الثقب على الساخن
- 9- اشتراطات السلامة الخاصة بالثقب على الساخن



# **S21-Safety Of Portable ladders and scaffoldings**

## **Objectives :**

This course it to give closed look for the safety of portable ladders and scaffoldings, and injuries that could result from them.

## **Who should attend :**

Marine workers, maintenance engineers and technicians, safety specialists and Forman, who are practicing safety

## **Duration:**

5 days (20 Hr)

## **Course Outline:**

- 1- introduction
- 2- definitions
- 3- types of fixed ladders
- 4- types of portable ladders
- 5- types of scaffolds
- 6- safety requirement for scaffolds
- 7- foundations / SILLS
- 8- general rules for ties
- 9- common methods for tying
- 10- planking
- 11- loads
- 12- P.P.E.

# **S22-Job Hazard Analysis & Risk Calculation**

## **Objectives:**

The course is to understand J.H.A. and how to calculate the risk.

## **Who should attend :**

Process engineers and technicians, Maintenance engineers and technicians, safety specialists and Forman, who are practicing safety

## **Duration:**

5 days (20 Hr)

## **Course Outline:**

- 1- Five steps process of JHA.
- 2- Goals
- 3- Form team
- 4- JHA key terms
- 5- Activity
- 6- JSA purpose
- 7- Probability
- 8- Severity
- 9- Decision making matrix
- 10- Identifying types of hazards
- 11- Accident types
- 12- The hierarchy of controls

## S23- القيادة الآمنة و سلامة أوناش الشوكة

### \* الهدف من البرنامج

التعريف على اشتراطات السلامة الواجب توافرها أثناء قيادة السيارات اوناش الشوكة كذلك معايير السلامة المختلفة الخاصة بها.

### \* المؤهل لحضور البرنامج :

السائقين ، سائقى اوناش الشوكة ، رجال السلامة.

### \* مدة البرنامج

خمسة ايام ( 20 ساعة )

### \* محتويات البرنامج

- 1- تعريف القيادة الآمنة
- 2- حوادث التصادم
- 3- انواع اخرى من حوادث التصادم
- 4- اسباب الحوادث
- 5- اسباب حوادث التصادم الذاتية
- 6- قيادة السيارة فى الظروف الطارئة
- 7- اشتراطات السلامة لتشغيل اوناش الشوكة

# **S24-Fire Fighting Pumps**

## **Theory, Construction, Operation and Maintenance**

### **Objectives:**

The aim of this course is to enhance the knowledge and skills of participating engineers and technicians about fire fighting pumps. Emphasize is placed on the construction, operation, and maintenance of fire fighting pumps. Participants will understand pump technology and performance. Applications and different techniques of troubleshooting are also presented. It provides in-depth understanding of pump maintenance and overhauling procedures.

### **Who Should Attend:**

Safety department maintenance & technical support engineers and supervisors.

### **Duration:**

5 days (20 hrs)

### **Course Outline:**

- 1. Introductions**
- 2. Pump Classifications**
  - Dynamic pumps
  - Positive displacement pumps
- 3. Centrifugal Pump Design**
  - Fluid concepts and velocity triangles
  - Head and capacity calculation
  - NPSH
  - Specific speed
- 4. Pump Performance**
  - Pump characteristics
  - Head capacity curve and operating point
  - Effects of pump speed, impeller diameter and operating conditions
  - Series and parallel operation and system head curves
- 5. Pump Construction**
  - Casing types
  - Impeller/rotor

- Casing and impeller wear rings
- Seals and packing
- Bearings and lubrication

#### **6. Pump Operation**

- Start-up and shutdown conditions
- Minimum flow operation
- Off-design operation

#### **7. Pump Maintenance**

- **General maintenance procedure**
  - ❖ Preparation for pump maintenance work
  - ❖ Checks before dismantling
- **Disassembly procedures**
  - ❖ Removal of coupling
  - ❖ Dismantling of seals
  - ❖ Dismantling of bearings
  - ❖ Removal of rotor/impeller
  - ❖ Remove of casing and impeller wear rings
- **Parts Inspection, measuring and Repair or replacement**
- **Precision Assembly Techniques**
  - ❖ Installation procedure
  - ❖ Installation of shaft seals and packing
  - ❖ Installation of bearings
  - ❖ Check and set of clearances and axial play
  - ❖ Assembly errors
  - ❖ Proper fitting of shafts and bores
  - ❖ Proper set screw assembly
  - ❖ Effects of non-square faces
  - ❖ Care in assembly of couplings
- **Typical Pump Problems And Troubleshooting**
  - ❖ Cavitation
  - ❖ Liquid circulation
  - ❖ Vibration
  - ❖ Excessive power consumption
  - ❖ Failure analysis and troubleshooting
  - ❖ Seals and bearings common troubles

#### **8. Specifications And Selection Techniques**

#### **9. Pumps Maintenance Strategy**

#### **10. Case Studies And Workshop**

# **S25-Integrated Management Systems (IMS)** **for Safety Specialists**

## **Objectives :**

Explain the IMS Philosophy

Provide an Overview of How IMS Is Structured

Explain Systems Details

Clarify Roles & Responsibilities to Implement the System

Agree On Path Forward

## **Who Should Attend:**

Process engineers that involved in emergency plans, General Managers and mid managers, EHS managers & specialists, and any other personnel that involved in a contingency plan.

## **Duration:**

5 days (20 hrs)

## **Course Outline:**

### **Day 1**

- Leadership & Accountability
- Risk Assessment & Management

### **Day 2**

- Training & Orientation
- Facilities Design & Construction
- Operations & Maintenance

### Day 3

- Management of Change
- Contractors

### Day 4

- Documentation System
- Crisis & Emergency Management

### Day 5

- Incident Investigation & Analysis
- Audit & Management Review

## **HSE- Certified Safety courses & Diploma**

HSE01-QHSE Professional Diploma (SPD)

HSE02-Sport Management Diploma (SMD)

HSE03-Professional QHSE Manager (PSM)

HSE04-Certified QHSE Compliance Inspector (SCI)

HSE05-QHSEMS Lead Auditor

HSE06-Certified Risk Assessor (CRA)

HSE07-Certified Incident Investigator (CII)

HSE08-Certified Emergency Responder (CER)

HSE09-Certified Lifting Inspector & Planner (CLIP)

HSE10-Certified Scaffold Inspector (CSI)



## **HSE01-QHSE Professional Diploma (SPD)**

### **Introduction:**

Quality, Health, Safety & Environment Professional Diploma program is aiming to teach candidates who are working in the HSE field or working in inside the construction & industrial sites the technical requirements of Occupational Health and Safety Administration (OSHA) regulations and the awareness of other relevant legislation, standards and ACOP.

### **Expected outcomes:**

- Show you how to, identify and manage the workplace hazards, perform a safety inspection and investigate, analyze and document a workplace incident
- Cover identifying the potential hazards of chemicals, determining the proper PPE for employees and chemical safety in general
- Show you how to deal with hazardous materials and become both OSHA and environmentally compliant
- Cover fall hazards and methods of reducing them, along with the safe use of stairways, ladders and scaffolds
- Show you how to identify safety requirements for cranes, derricks, hoists and elevators and best techniques for rigging and slings
- Show you how to become a safety expert and develop/implement your own safety training programs And much more!

### **Name of Course(s) Within this Program of Study:**

• Subparts from OSHA, 1926 (Workplace Environmental Control – Record Keeping – Working at Height – Rigging and Lifting Safety – Electrical Safety – etc)
• Subparts from OSHA, 1910 (Means of Egress – Confined Space – overhead Crane – Chemical Safety – Working Surface – etc)
• OSHA Process Safety Management
• Risk Management
• HAZOP Study

## **HSE02-Sport Management Diploma (SMD)**

### **Introduction:**

CSA Diploma in Sport (Advanced Sport Management) is a full-time, Level 6 tertiary qualification. Students enter after the successful completion of their Diploma in Sport Management and Exercise Prescription or can qualify through the RPL (Recognition of Prior Learning) system.

Sport Management students are able to practically apply what they learn during the year through the organization of large commercial and non-profit events to gain valuable experience. Their event management skills are developed and improved through direct involvement in the planning and implementation of major multi-faceted events.

Graduates in Sport Management will finish the Diploma with transferable business skills in marketing, management, coaching and administration.

Diploma graduates are suited for employment in a wide range of sporting organizations including Regional Sports Trusts, sport facilities, sport clubs and societies and other commercial sport businesses.

### **Expected outcomes:**

Graduates in Sport Management will finish the Diploma with transferable business skills in marketing, management, coaching and administration.

### **Name of Course(s) Within this Program of Study:**

- Strategic Planning – Sport organization development
- Sport Education – Officiating and competition formatting
- Sponsorship – Proposal design and implementation
- Marketing and Promotion
- Advanced Event Management
- Sports Law
- Special Populations
- Information Technology
- First-line Management & Risk Management
- Advanced Coaching & Programs Development

## **HSE03-Professional QHSE Manager (PSM)**

### **Introduction:**

This Safety Manager Certification is an indication to employers, potential employers, regulatory agencies, and the courts that you have the knowledge, skills, and abilities equivalent to a level of proficiency expected of a professional who is capable of working with little or no supervision while managing the safety programs, policies, and procedures common to business and industry. The Certified Safety Manager (CSM) is achieved by completing the Safety Manager/Trainer Certification course and completing the Certified Safety Auditor (SAC), which includes the Hazard Analysis Technician, Safety Inspections Technician and Accident Investigations Technician courses. Both the STS and SPS may be earned through completing the NASP Safety Manager/Trainer course.

### **Expected outcomes:**

- How to analyze and document workplace hazards
- How to perform a workplace safety inspection
- How to investigate, analyze and document a workplace accident
- A new and empowering perspective on workplace safety
- How to perform as a safety expert and develop your own safety program
- How to create a successful safety culture And much more!

### **Name of Course(s) Within this Program of Study:**

- Bloodborne Pathogens
- Confined Space Entry
- Electrical Safety
- Ergonomics
- Hazard Communication - Hazardous Materials
- HAZWOPER (if HTS and Technician Certifications are current)
- Inspections
- Lockout Tagout
- Machine Guarding
- Materials Handling
- Egress/Fire Safety
- PPE - Record Keeping

- Workplace Violence
- Walk/Work Surfaces - Weld/Cut/Braze

## HSE04-Certified QHSE Compliance Inspector (SCI)

### Introduction:

A workplace inspection is a critical part of a comprehensive safety and health program in which the workplace is examined closely on a regular basis for the purpose of:

- Identifying and recording potential and actual hazards associated with buildings, equipment, environment, processes, and practices
- Identifying any hazards which require immediate attention, whether they are unsafe conditions or unsafe acts
- Ensuring that existing hazard controls are functioning adequately; and where appropriate, recommending corrective action.

Within any safety program, there may in fact be a variety of types of inspections, for example:

- Spot inspections may be undertaken on a random basis as part of general safety responsibilities;
- Pre-operation checks of special equipment or work processes are often necessary before work is carried out;
- Critical parts inspections are regular planned inspections of those critical parts of a machine, piece of equipment, or system which have a high potential for serious accidents. They are often part of planned or preventive maintenance procedures, or hazard control programs;
- New equipment inspections are thorough inspections and checks before operations begin;
- Regular planned inspections are done on a regular basis in a defined workplace and cover all conditions including work practices and procedures.

There is no more important skill to the safety professional than the ability to discover and remedy hazards before they can injure workers. The course materials include inspection forms with CFR references designed for twenty different areas of your facility.

**Expected outcomes:**

Upon successful completion of this course, the student will be able to identify and record potential and actual hazards associated with facilities, equipment, environment, processes and practices; be able to identify and report any hazards which require immediate attention; be able to determine that existing hazard controls are functioning adequately and recommend corrective actions when necessary.

**Name of Course(s) Within this Program of Study:**

Scope and Application

Workplace Safety Inspections as a Part of the Safety and Health Program

Information Requirements

Ensuring That Existing Hazard Controls Are Functioning

Types of Inspections

Spot Inspections

Pre-operation Checks

New Equipment Inspections

Regular Planned Inspections

Inspecting the Following:

Review Related Safety Plans, Programs, Policies, and Procedures

Hazard Communication

Electrical Safety

Working at Height & Scaffold Safety

Fire Protection and Prevention

Excavations Safety

Confined Spaces

Cranes & Slings

## HSE05- QHSEMS Lead Auditor

### Introduction:

This is a comprehensive and thorough course. There is no more important skill to the safety professional than the ability to discover and remedy hazards before they can injure workers. This is the purpose of the workplace safety auditor and his & her three primary tools: Hazard Analysis, Inspections, and Accident Investigation.

The purpose of a workplace safety audit is to discover circumstances, situations, equipment, or materials that may harm a person. The objective is not regulatory compliance, and it is not saving money, it is the avoidance of human injury. Regulatory compliance and monetary gain are collateral benefits, not the primary objective. It is a certainty that accidents cost money. They cost money in medical expenses, insurance, lost work, and a variety of indirect costs. Regulatory compliance is also an important part of ensuring a safe workplace. But there is not a regulation to cover every hazard. In fact, OSHA addresses this issue by citing the General Duty Clause when no specific standard applies to a situation that could injure a worker. The General Duty Clause states, "Each employer shall furnish to each of his employees, employment and a place of employment which are free from recognized hazards that are causing or are likely to cause death or serious physical harm to his employees".

Be sure that the hazards you discover are remedied in a timely fashion. For every hazard you discover, you must first attempt to eliminate the hazard through Engineering Controls. If the hazard cannot be remedied by Engineering Controls then you must attempt to eliminate or control it through Administrative Controls. Only if it cannot be controlled by Engineering Controls or Administrative Controls may you use PPE as the remedy.

Above all, remember that people will retain or lose life and limb based upon how well you perform the safety audit function.



**Expected outcomes:**

- How to analyze and document workplace hazards
- How to perform a workplace safety inspection

How to investigate, analyze and document a workplace accident and much more!

**Name of Course(s) Within this Program of Study:**

- Requirements of ISO 14001 & 9001
- Requirements of OHSAS 18001 & ISO 22001

## **HSE06- Certified Risk Assessor (CRA)**

### **Introduction:**

This course discusses Job Hazard Analysis, Change Analysis, Process Hazard Analysis, and Phase Analysis. The course includes a comprehensive Job Hazard Analysis tool. Job Hazard Analysis (or Job Safety Analysis) is the most widely used and effective means of identifying potential hazards in routine work performance. The Job Hazard Analysis is more effective in eliminating and reducing injuries and illnesses in the workplace because it not only uncovers hazardous conditions, it also identifies unsafe work practices and procedures. Combining Job Hazard Analysis with Change Analysis, Process Hazard Analysis, and Phase Analysis provides a well rounded a complete hazard analysis program.

### **Expected outcomes:**

Upon successful completion of this course, the student will be able to critically analyze each step of a job for unsafe conditions and unsafe practices, determine whether the hazards can be eliminated or the job could be performed differently to reduce exposure to the hazards.

### **Name of Course(s) Within this Program of Study:**

Risk Assessment Methodology  
Defining Tasks – Observation - Objectives  
    Work Procedures - Hazard Abatement  
Preparing for the Job Hazard Analysis (JHA)  
The 5 Steps of Performing the JHA  
Performing the Process Hazard Analysis  
Phase Hazard Analysis  
    What – When – Why - How

## **HSE07- Certified Incident Investigator (CII)**

### **Introduction:**

Accidents are unplanned and unintentional events that result in harm or loss to personnel, property, production, or nearly anything that has some inherent value. Accidents are rarely simple and almost never result from a single cause. Most accidents involve multiple, interrelated causal factors. Accidents can occur whenever significant deficiencies, oversights, errors, omissions, or unanticipated changes are present. Any one of these conditions can be a precursor for an accident; the only uncertainties are when the accident will occur and how severe its consequences will be. To conduct a complete accident/incident investigation, the factors contributing to an accident, as well as the means to prevent accidents, must be clearly understood.

Management prevents or mitigates accidents by identifying and implementing the appropriate controls and barriers. Accidents occur when one or more barriers in a work system, including procedures, standards, and requirements intended to control the actions of workers, fail to perform as intended. The barriers may not exist, may not be adhered to, or simply may not be comprehensive enough to be effective. Personal performance and environmental factors may also reduce protection.

Understanding how to prevent or control accidents requires an understanding of the sequence of events leading to an accident in order to identify and implement countermeasures that contain risks.

The purpose of this course is to provide those responsible for conducting accident investigations with practical, detailed instruction on conducting these investigations. The course provides in-depth guidance, as well as specific tools and techniques that will facilitate the investigation process.

### **Expected outcomes:**

Upon successful completion of this course, students will be able to conduct complete accident investigations by collecting and analyzing data, identifying barriers in procedures, standards and requirements

that lead to accidents, and implementing appropriate controls to prevent accidents.

**Name of Course(s) Within this Program of Study:**

- Direct Cause
- Contributing Causes
- Root Causes
- The Importance of Causal Factors
- Using the Core Analytical Techniques
- Events and Causal Factors Charting
- Barrier Analysis
- Change Analysis
- Events and Causal Factors Analysis
- Root Cause Analysis
- Developing Conclusions and Judgments of Need
- Conclusions
- Judgments of Need
- Reporting the Results
- Writing the Report
- Report Format and Content
- Disclaimer
- The Initial Investigation at the Accident Scene
- Immediate Post-Accident Actions
- Preserving and Documenting the Accident Scene
- Securing and Preserving the Scene
- Documenting the Scene
- Collecting, Preserving, and Controlling Evidence
- Obtaining Initial Witness Statements

- Managing the Investigation Process
- Taking Control of the Accident Scene
- Initial Meeting of the Investigators
- Promoting Teamwork
- Managing Information Collection
- Managing Report Writing
- Collecting Data
- Collecting Human Evidence
- Locating Witnesses
- Conducting Interviews
- Collecting Physical Evidence
- Documenting Physical Evidence
- Inspecting Physical Evidence
- Removing Physical Evidence
- Collecting Documentary Evidence
- Examining Organizational Concerns, Management Systems, and Management Oversight
- Preserving and Controlling Evidence

## **HSE08-Certified Emergency Responder (CER)**

### **Introduction:**

This course prepares the student to meet the workplace safety needs for Fire Protection and Prevention, Exits and their requirements, Plans related to fire and other emergencies, and First Aid requirements. This course includes OSHA's recent changes to Subpart E and its new approach to what OSHA now refers to as their "Emergency Standards

### **Expected outcomes:**

Upon successful completion of this course, the student will be able to understand and explain the three elements of fire protection, identify types of fire suppression equipment, understand the requirements for exit routes, design and implement emergency action plans, and understand how to meet the requirements of first aid training.

### **Name of Course(s) Within this Program of Study:**

- Maintenance, Safeguards, and Operational Features for Exit Routes
- Emergency Action Plans
- Fire Prevention Plans
- Medical Services and First Aid
- Requirements
- Time Limits
- Fire Behavior - Fire Extinguishers
- New NFPA 10 Requirements
- Fire Brigades
- Fire Prevention
- Standpipe Systems - Sprinkler Systems - Alarm Systems
- Exit Routes
- Coverage and Definitions - The Life Safety Code Orientation

## **HSE09-Certified Lifting Inspector & Planner (CLIP)**

### **Objectives:**

- Thorough explanation of all the regulations associated with Lifting & Rigging such as Egyptian National and International Lifting Legislation and Regulations (Including OSHA and LOLER) and Lifting /Rigging ACOPs. Various different safety practices associated with rigger/slinger activities.
- The terminology used to identify component parts and the proper use and purpose of all equipment used when rigging.
- How and when to select/use the correct chains and wire rope slings.
- Lifting and Rigging gears' Pre-Use Inspections
- Working with the various lifting gears.
- Perform pre-use inspections.
- Slings various loads shapes and weights.
- The candidates will undergo various practical assessments covering the rigging aspects of the course including working with lifting equipment before taking part in a practical examination
- Workshops about how to make rigging and lifting routine and critical plan for different types of cranes & sling rigging ;
- Practice on how to fill the forms related the routine & critical lift
- Course over view;
- Exam for Rigging & Lifting Planner course (3Hrs) and Rigging Operations.
- The Lifting and rigging management system
- Importance and documents/formats associated with rigging/slinging and how to correctly complete it.
- The Lifting & Rigging standards expected on site and why it is Important to maintain them.
- The correct method of handling, using and Inspecting lifting tackle and the legal Requirements applicable to the maintenance, inspection and marking for identification.
- How to develop Rigging plan for simple Loads determining rigging points and gears.
- How to use and implement Crane Load Charts properly and calculate all lifting essential loads and dimensions.
- How to develop a detailed lifting plan for Normal/critical lifts
- Review and implement Rigging and Lifting plans and steps for Planning Lifting
- Exam for Rigging & Lifting Supervisor course (2 Hrs);

### **Name of Course(s) Within this Program of Study:**

- Detailed explanation of LEEA Part 1 Entrance Certificate is the basic level training course and will be conducted as follow:

- 1.1 - The Law
- 1.2 - Standards and Codes of Practice
- 1.3 - Materials
- 1.4 - Methods of Manufacture
- 1.5 - Stress and Strain in Lifting
- 1.6 - Destructive and Non-Destructive Testing
- 1.7 - Verification of Lifting Equipment
- 1.8 - Chains for Lifting Purposes
- 1.9 - Wire Rope Construction

- 1.10 - Revision Assignment
- 1.11 - Components
- 1.12 - Chain Slings
- 1.13 - Wire Rope Slings
- 1.14 - Shackles
- 1.15 - Eyebolts
- 1.16 - Textile Slings
- 1.17 - Mechanics - Simple Machines
- 1.18 - Feedback Session



## HSE10- Certified Scaffold Inspector (CSI)

### Objectives:

- Planning a scaffold job;
- Scaffolds Design
  - Identify the major items to consider when performing a scaffold Inspection through the following:
    - First Level of Scaffold Inspection (Scaffolds Material)
    - Second Level of Scaffold Inspection (Work Area)
    - Third Level of Scaffold Inspection (completed scaffolds)
  - Scaffold Tagging System
  - Scaffolding Certificate
  - Scaffold Inspection Checklist
  - Scaffolding Material Delivery Form
  - Scaffold Risks & Controls
  - Specify the Major Elements of OSHA's Regulation 29 CFR Subpart L- Scaffolding
  - Specify the general requirements for frame , tube & clamp and system scaffold;
  - hands on
  - Determine specific safety rules and steps associated with the erection of frame scaffolding;
  - Determine specific safety rules and steps associated with the erection of tube & clamp, frame and system scaffolding;
  - Step by step assembly procedures Inspection of completed scaffolds
    - Reviews for OSHA regulations of Subpart L & M;

**WL-Wire line courses:**

WL01- Wire line Operations.

WL02- Advance Wire line course

WL03- Wellhead Operations Maintenance & Testing

## **WL01- Wire Line Operation**

### **Course Objective:**

This course will familiarize engineers and field personnel with the principles and operational practices which must be used to achieve maximum success in intervention, production and workover operation.

### **Who Should Attend?**

Production Engineer, Wire Line Supervisor, Wire Line Operator, Production Operator, District Engineer, Drilling Engineer, Operation Engineer.

### **Course Duration:**

**5 Days**

### **Course Contents:**

- Introduction.
- Surface Equipment.  
General stuffing box , line wiper, Grease injector head , quick unions, lubricator , wire line B.O.P. ,x-mass tree , weight indicator ,hay pully , wire clamp , rigging up , projects ,
- Wire Line Unit And Wire Line.  
Typical casing schematic, the well head, tubing, wireline inspection, wireline counter, wireline units project
- Tool String.  
Tool string ,rope sockets, stem , lead filled stem , mechanical jars , hydraulic jar , spring jar , tool string preparation , fishing neck size , gauge cutter , knuckle joint / swivel, blind box , impression block ( L.I.B), swaging tool , tubing end locator, quick lock type connection, Project.
- Standard Pulling And Running Tools  
Otis R and S series, OTIS g series, shear pin theory, tool hart Z-6 running tool, Project.
- Lock Mandrels.  
Introduction to lock mandrel , W – slip lock , w – running tool , D- collar lock , G- element ,nipple locks ( S ,N ,XN) , x/xn Pulling and running procedure, Project.
- Plugs and Equalizing Subs.  
Introduction, D plug, pulling prong chart, DW, DD, XX plug assembly, pump open plug and wireline bridge plug Project.
- Test Tools.  
N test tool modified PX test tool, X selective test tool, Project.
- Sliding Sleeves.  
X-O SSD, X-A and X-D SSD, B shifting tool, selective downshift tool, side door choke, Project.
- Perforator , Bailers and back pressure valve  
Type a perforator , running options , f collar and f tubing stop , f perforator stop , sand bailing , pump bailer , hydrostatic bailer ,
- Pack Offs.  
G pack off assembly, installation options.

## **WL02-Advance wire line course**

### **Course Objectives**

Upon the completion of this course, participants will learn more about wire line fishing ,sssv , gaslift equipment and new technology. Also, attendees will develop a better understanding about wire line operating procedures & working under safe conditions.

### **Should Who Attend**

Field Operations, Production, Petroleum, Reservoir, Field Engineers and other staff interested in wire line wire line supervisors ,wire line operators.

### **Course Program**

The following program is planned for this course. However, the course instructor(s) may modify this program before or during the course for technical reasons with no prior notice to participants. Nevertheless, the course objectives will always be met

- Introduction
- Scssv (tubing retrievable and w/l retrievable)
- Sscsv
- Equalizing feature
- Trouble shooting Name the different AL systems used
- Understand the principles of gas lift
- Side Pocket Mandrels
- Equipment used for Valve change-outs
- Valve latches
- Running tools
- Gas lift valves
- Fishing operation hints
- Detect where the wire when broke in hole
- All fishing job equipment and features
- Case study
- Familiarization with Baker flow control equipment
- Standard and Surset Landing Nipple and lock specifications
- Baker Probes,shanks and prongs
- Equalization devices and their associated running/pulling tools -Running procedures
- Pulling procedures -Baker Nomenclature
- Weatherford equipment
- Advanced slick line equipment
- New technology
- Exercise and final test

# **WL03-Wellhead Operations Maintenance & Testing**

## **Course Objectives**

Upon the completion of this course, participants will learn more about x-mas tree, wellhead equipment, valves maintenance and greasing, safety valves and wellhead control system. Also, attendees will develop a better understanding about wellhead operating procedures & working under safe conditions.

## **Should Who Attend**

Field Operations, Production, Petroleum, Reservoir, Field Engineers and other staff interested in X-mas trees & wellhead operations and testing.

## **Course Program**

The following program is planned for this course. However, the course instructor(s) may modify this program before or during the course for technical reasons with no prior notice to participants. Nevertheless, the course objectives will always be met:

- 1- Surface equipment
- 2- Choke valves
- 3- Christmas tree
- 4- Well completion
- 5- Function of x-mass tree
- 6- Function of the well
- 7- X-mass tree valves & maintenance and testing
- 8- Flanged x-mas tree
- 9- Compact well head and x-mass tree -----x-mass tree selection
- 10- Flanging of the well head
- 11- Well head maintenance

- 12- Common problem and solution ( prevention and solution )
- 13- Valves lubrication and maintenance/ land base inspection / landing base repair
- 14- Annuli problems and remedial action to resolve problem
- 15- Well control intervention safety
- 16- Material selection

## **O-Offshore Courses:**

O01- Introduction to Offshore Oil and Gas Platforms

O02- Steps for Building an Offshore Platform

O03- Special Features Of Offshore Platforms Projects

O04-Structural Engineering of Offshore Platforms

O05- Under Water Steel Structure Inspection & Repair

O06- Offshore Pipelines Engineering & Construction

# **O01-Introduction To Offshore Oil And Gas Platforms**

## **Objectives**

Provide basic knowledge about the form, type and components of offshore platforms.

## **Who Should Attend**

The course is beneficial to all personnel who have to deal with offshore platforms whether on the projects side, operations side, drilling side, exploration side, commercial side, financial side and legal side.

Young engineers and senior engineers who were not exposed to offshore activities will benefit from the course.

Attendees are not required to hold an engineering degree.

## **Duration**

3 sessions, 3 hours per session

## **Outline**

- What is an offshore platform?
- Types of offshore platforms
- Main components of offshore platforms



# **O02-Steps For Building An Offshore Platform**

## **Objectives**

To provide a wide overview on the scope of work required to build an offshore platform

## **Who Should Attend**

The course is beneficial to all personnel who have to deal with offshore platforms whether on the projects side, operations side, drilling side, exploration side, commercial side, financial side and legal side.

Young engineers and senior engineers who were not exposed to offshore activities will benefit from the course.

Attendees are not required to hold an engineering degree.

## **Duration**

3 sessions, 3 hours per session

## **Course Outline :**

- Concept definition
- Front End Engineering
- Detailed Engineering
- Bidding
- Procurement
- Fabrication
- Installation

# **O03-Special Features Of Offshore Platforms Projects**

## **Objectives**

To identify special activities that are unique to offshore platforms projects and have major influence on decision making.

## **Who Should Attend**

Personnel who have to deal with offshore platforms whether in the planning phase, front end engineering phase, basic engineering phase, detailed engineering phase, construction phase, installation phase, commissioning phase, operation phase and maintenance phase.

## **Duration**

4 sessions, 3 hours per session

## **Course Outline**

- Drilling
- Submarine Pipelines
- Geotechnical Conditions
- Geophysical Conditions
- Meteorological and Oceanographic Conditions
- Engineering Capabilities
- Fabrication Constraints
- Loadout Constraints
- Transportation Constraints
- Installation Constraints

# **O04-Structural Engineering of Offshore Platforms**

## **Objectives**

The features of offshore platforms installed in the Egyptian waters are such that the bulk of the engineering man-hours are consumed by the structural engineering discipline. This course aims at explaining the different activities performed by the structural engineering discipline.

## **Who Should Attend**

The course is beneficial to all project management personell, whether discipline engineers or management.

## **Duration**

4 sessions, 3 hours per session

## **Course Outline**

- Design Loads and Forces
- Foundation Design
- Structural Analysis

# **O05-Under Water Steel Structure**

## **Inspection & Repair**

### **Objectives :**

- General idea about the under water steel structure
- Some ideas about diving operation
- Inspection techniques for under water steel structure
- Repair activities and procedures explanation

### **Who Should Attend**

The course is beneficial to all project management personell, whether discipline engineers or management.

### **Duration**

5 days (20hrs )

### **Course Outline :**

#### **Part ( 1 ) Inspection Techniques**

1. Diving
  - A. Air Diving
  - B. Saturation Diving
2. Inspection
  - A. Inspection of Structure
  - B. Pipeline Inspection
  - C. Subsea Inspection

#### **Part ( 2 ) Offshore Structure Repair**

- B. Causes of Offshore Repair
- C. Repair methods
  - Under Water cutting
  - Under Water welding
- D. Repair Equipment

# **O06-Offshore Pipelines**

## **Engineering & Construction**

### **Objectives :**

- General idea about the Offshore Pipeline
- Offshore Pipeline engineering, installation , Inspection & Laying out
- In services Stage

### **Who Should Attend**

The course is beneficial to all project management personell, whether discipline engineers or management.

### **Duration**

5 days (20hrs )

### **Course Outline :**

1. Pipeline Engineering
2. Material Selection
3. Pipeline Production
4. Pipeline Welding & Inspection
5. Pipeline Installation

## **R-Reservoir Engineering**

R01- Applied Reservoir Engineering

R02- Basic Reservoir Engineering

R03- Basic Well Test Analysis

R04- Production optimization using NODAL analysis

R05- Water- flooding Design, Operations and Monitoring

R06- PVT Analysis & Equation of State for Compositional Simulation

R07- Reservoir Simulation

R08- Formation Damage, Causes and Prevention

R09- Modern Well Test Analysis

R10- Reservoir Management

R11- Reservoir Characterization

R12- Hydraulic Fracturing

R13- Well Stimulation & Hydraulic Fracturing Technology

## R01- Basic Reservoir Engineering

### Course Objects:

The intent of Basic Reservoir Engineering is development of a more complete “understanding” of the characteristics of oil and gas reservoirs, from fluid and rock characteristics through reservoir definition, delineation, classification, development plan, and production. Data collection, integration and application directed toward maximizing recovery are stressed. Basic reservoir engineering equations are introduced with emphasis directed to parameter significance and an understanding of the results

### Who Should Attend?

Geologists, geophysicists, engineers, engineering trainees, technical managers, technical assistants, technicians, chemists, physicists, technical supervisors, service company personnel, sales representatives, data processing personnel, and support staff working with reservoir definition, development and production.

### Course Content:

- Introduction
- Generation of hydrocarbons
- Rock properties
- Trap mechanisms
- Coring
- Routine & Special core analysis
- Coring techniques & devices
- Coring fluids
- Cores packing
- Factors affecting invasion
- Porosity measurement
- Permeability
- Overburden effects on pore volume
- Initial water saturation distribution
- Relative permeability
- Net pay cut-off
- General behavior
- Material balance principle
- Solution gas drive performance
- Water drive performance
- Bottom water drive/coning
- Decline curve analysis
- Gas reservoir performance
- Reserve booking

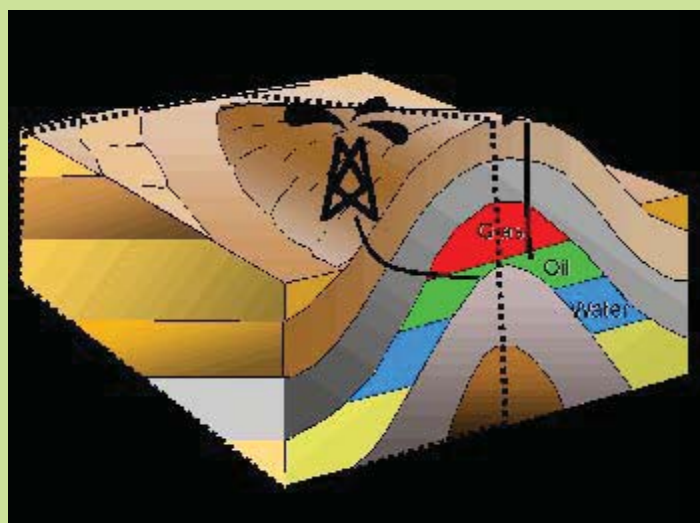

### Course Duration: (5) Days

## R02-Applied Reservoir Engineering

### Course Objective:

- 1 Obtain from laboratory tests or correlations valid reservoir rock and fluid properties for use in reservoir engineering calculations.
- 2 Analyze the qualitative and quantitative aspects of rock and fluid property behavior at both reservoir and surface conditions.
- 3 Use the pressure data to understand the reservoir/well performance.
- 4 Recognize the characteristics of primary reservoir mechanisms and apply the appropriate material balance, fluid displacement and water influx equations to predict future reservoir performance.

### Who Should Attend?

Petroleum engineers (especially reservoir engineers) of four years experience or more, The course can be tailored to be given for less experience trainees.

### Course Content:

#### **1. Rock Properties:**

- Routine core analysis: porosity, permeability, water saturation and grain density.
- Overburden effects on porosity and permeability.
- Core samples selection, handling, and preparation for special core analysis.
- Special core analysis: relative permeability, capillary pressure, compressibility, and electrical properties.
- Core data averaging and normalization.
- Core data to log calibration.
- Net pay cut-offs: porosity, permeability, water saturation and shale cut-offs.
- Reservoir heterogeneity: permeability variation, areal and vertical sweep efficiencies, displacement efficiency and mobility ratio.
- Water and gas coning.

#### **Fluid Properties:**

- Characterization of Reservoir Fluids: chemistry of hydrocarbons, classification of reservoir fluids, compositional analyses.
- Applications of Reservoir Fluid Data.
- Reservoir Oil Correlations: importance of empirical PVT correlations, regional trends of crude oils compositions, PVT correlations parameters, ranges of PVT data used in the correlations.
- Phase Behavior: hydrocarbon phase behavior, properties of hydrocarbon gases, equilibrium ratios, pseudo critical temperature and pressure, gas properties correlations, dewpoint pressure correlation.
- Reservoir Fluid Sampling: obtaining representative samples, well conditioning, hydrocarbon surface and sub-surface sampling procedure
- Reservoir Fluid Analysis: laboratory experiments, flash versus differential liberation, PVT compositional analysis.
- Adjustment of PVT Data for Field Separator Conditions
- Compositional Gradient within the Hydrocarbon Column



3. Well Testing Analysis:

- Types of Well Tests, Design of well tests.
- Understand the reservoir performance from the well testing results.

4. Recovery Mechanisms:

- Material balance principles (history match and prediction) for, solution gas drive, water drive, gas cap drive, gravity drainage and combination drive mechanisms.
- Reserve estimation using decline curve analysis, fractional flow analysis techniques, and empirical formulas.

**Course Duration: (5) Days**

## R03-Basic Well Test Analysis

### Course Objective:

The course emphasizes the practical application of well test theory to the solution of real well testing problems from design through interpretation for oil, gas and water injection wells. Participants will be introduced to a systematic approach to well test analysis and will apply it using modern well test analysis software. Numerous data sets with non-ideal behavior will be reviewed and analyzed to allow participants to gain experience with real world problems. Participants will be able to apply their newly acquired skills in their job assignments immediately upon course completion.

### Course Objectives:

By the end of the course, participant will learn:  How to design well test and specify equipment requirements.  How to set up and analyze well test for oil and gas wells  Perform QC analysis for pressure data; identify and discard bad data.  Identify various well bore and reservoir characteristics and chose the appropriate model for analysis.

### Who Should Attend?

Engineers and geoscientists who want to understand well testing principles and interpretation techniques to design, analyze, report, evaluate results or intelligently participate in the well testing process. Previous experience in well testing, production operations and reservoir engineering is helpful but is not required.

### Course Content:

- Opening
- Pre-test
- Introduction.
- Reasons and types of well testing.
- Fundamentals of well testing.
- Well testing down hole control.
- Well testing design.
- Down hole and surface testing equipment.
- Well site testing data.
- Interpretation methodology.
- Specialized test types.
- Evaluation of well test analysis.
- Hydrocarbon reservoir description.
- Reservoir diagnosis via well testing.
- Reservoir fluid behavior.
- Welltest analysis theory.
- Factors affecting the well testing analysis.
- Well test analysis models.
- Post Test
- Closing

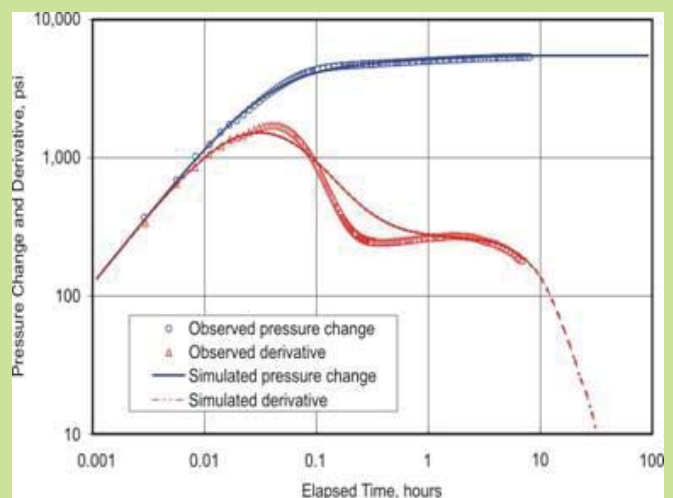

**Course Duration: (5) Days**

## R04-Production optimization using NODAL analysis

### Course Objectives:

- Apply NODAL™ analysis concepts viewing the total producing system as a whole from the reservoir rock through the completion, well bore and gathering system, to the market while honoring system rate/pressure constraints
- Avoid improper design where any one component, or a mismatch of components, adversely affects the performance of the entire system
- Perform a system-wide analysis to increase well rates by identifying bottlenecks and design an efficient field-wide flow system, including wells, artificial lift, gathering lines and manifolds
- Use NODAL™ analysis, together with reservoir simulation and analytical tools, for planning new field development

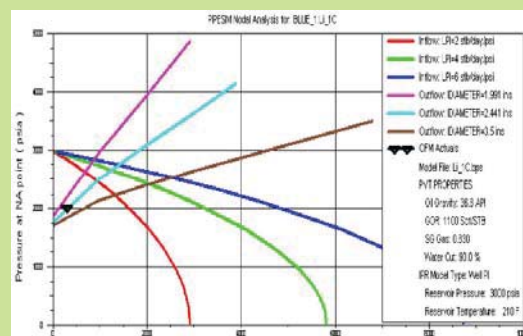

### Who Should Attend?

Exploration and production technical professionals, team leaders, managers, and support staff that requires a more extensive knowledge of production engineering and operations

### Course Content:

**General Overview of Nodal Analysis:** Supply/Demand analogies, natural balance and stable/unstable equilibrium concepts, diminishing returns, independent/dependent subsystems, converging/diverging flows

**Inflow Performance:** Reservoir performance basics, Darcy, Jones and Ramey turbulence parameters, empirical models of Vogel and Fetkovich, the benefits and drawbacks of well-test and C&N values, appropriate models for differing well descriptions, rigorous multi-layer IPR curves

including crossflow effects

**Completion Performance:** Completion modeling basics, perforation and gravel pack pressure drop, linear and radial flow patterns through gravel packs, the pressure drop in a gravel-filled wellbore, optimal perforation density, the rate reduction caused by a partial completion

**Tubing Performance:** Wellbore related pressure drops and dynamics, videotapes of vertical and horizontal flow patterns, diverging and converging flow dynamics, route preference, production logging physics in deviated/horizontal wellbores, wellbore slugging and pressure behavior in vertical, deviated, and horizontal wellbores, friction drop through restrictions and undulating horizontal sections, sonic flow and minimum lifting rates concepts, unloading techniques and examples

- Flowline Performance:** Panhandle, C&S, Dukler pressure drop models, identifying bottlenecks in a gathering network, line loops and jumpers, circular/parallel/layered gathering systems
- Future performance:** Integrating reservoir performance, development planning, and market constraints into field forecasts, optimizing capital investments when juggling new well, re-completion, compressor, artificial lift, and Flowline options
- Artificial Lift:** Advanced Gas lift design and troubleshooting, electric submersible pump fundamentals, jet pumps, and sucker rod pumping basics

**Course Duration: (5) Days**

## **R05- PVT Analysis & Equation of State for Compositional Simulation**

### **Course Objective:**

Obtain from laboratory tests or correlations valid reservoir fluid properties for use in reservoir and production engineering calculations, and analyze the qualitative and quantitative aspects of fluid properties, moreover, make use of the fluid properties in understanding the reservoir performance.

### **Who Should Attend?**

Petroleum engineers (especially reservoir engineers) of four years experience or more. The course can be tailored to be given for less experience trainees.

### **Course Content:**

- Characterization of Reservoir Fluids: chemistry of hydrocarbons, classification of reservoir fluids, compositional analyses
- Applications of Reservoir Fluid Data.
- Reservoir Oil Correlations: importance of empirical PVT correlations, regional trends of crude oils compositions, PVT correlations parameters, ranges of PVT data used in the correlations.
- Phase Behavior: hydrocarbon phase behavior, properties of hydrocarbon gases, equilibrium ratios, pseudo critical temperature and pressure, gas properties correlations, dew point pressure correlation.
- Reservoir Fluid Sampling: obtaining representative samples, well conditioning, hydrocarbon surface and sub-surface sampling procedures.
- Reservoir Fluid Analysis: laboratory experiments, flash versus differential liberation, PVT laboratory procedures and reports for gas – oil and gas condensate samples, hydrocarbon compositional analysis.
- Adjustment of PVT Data for Field Separator Conditions
- Compositional Gradient Within The Hydrocarbon Column
- Fluid Properties Prediction for The Reservoir Simulator Using Equation of State:
  - compositional simulation, options available in EOS PVT simulators, heavy ends characterization, extending C7+ distribution from lumped C7+ analysis, applications of EOS PVT simulators, pseudo components parameters tuning procedures for matching experimental analysis.
- Field cases.
- Technical papers.

### **Course Duration: (5) Days**

## **R06-Water- flooding Design, Operations and Monitoring**

### **Course Objectives:**

Water flooding has long been proven as the simplest and the lowest cost approach to maintaining production and increasing oil recovery from an oil reservoir. However, these benefits may fall far short of the expectations unless the time-tested concepts and practices are clearly understood and judiciously implemented. These concepts and practices aim at process optimization —reducing production cost while minimizing waste and maximizing oil recovery and income. This course is light on theory but heavy on proven and successful practices. Published case histories of projects around the world are reviewed to provide an understanding of divergent points-of-view, what works where, what fails when, and why?

This training covers all elements of a water flood project from A to Z — from source water selection to produced water disposal and everything in between. Participants are grouped into small multi-disciplinary teams. All classroom discussions and problem-solving sessions are handled in an asset-management team format.

The course material can be tailored to the needs of the participants and may be presented at various levels of depth and comprehension

### **Who should attend?**

Reservoir, production, facilities, research and development, and operations engineers who are involved with some aspects of a new or existing water flood project; geoscientists and professionals who want to get a better feel for the entire process of planning, development, management, and recovery optimization of a water flood project

### **Course Content:**

- Introduction
- Factors to Consider in Waterflooding
- Review of Rock and Flow Properties
- Recovery Efficiency Components
- Fluid Injectivity
- Practical Aspects of Waterflooding
- Economics

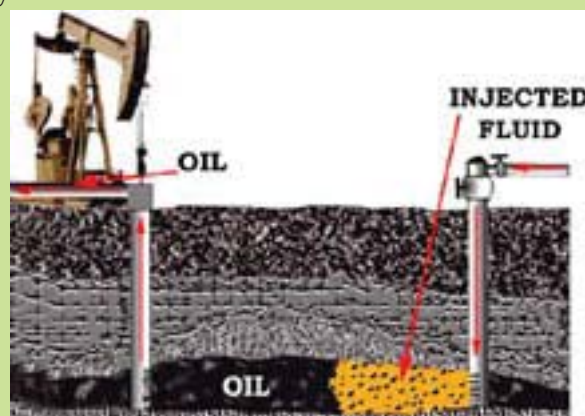

### **Course Duration: (5) Days**

## R07-Formation Damage, Causes and Prevention

### Course Objectives:

Commonly encountered formation damage processes, their operating mechanisms, theoretical bases, and parameters; procedures for diagnosis, measurement, and remediation of formation damage; prediction and simulation models, and model-assisted analysis of laboratory and field data.

**Who Should Attend?** This is an interdisciplinary course. Various professionals interested and/or involved in formation damage detection and control, including Reservoir Engineers, Production Technology Engineers, Drilling Engineers, and Production Facilities Engineers may benefit from this course.

### Course Content:

#### Introduction

- Porosity
- Permeability
- Permeability Measurements
- Skin Factor
- Formation Damage
- Critical Rate for fine migration

#### Causes of Damage

- Completion Procedures
- Drilling Fluids
- Perforation
- Production
- Scale Tendency
- Microbial

#### Effect of Damage

- Production
- Impact on Well Performance
- Cost of Damage.

#### Mitigation/Removal of Formation Damage

- Proper Design of Completion Procedures
- Selection of Completion Fluids
- Mitigation of Fine Movement
- Scale Inhibition
- Biocide Injection
- Formation Stimulation

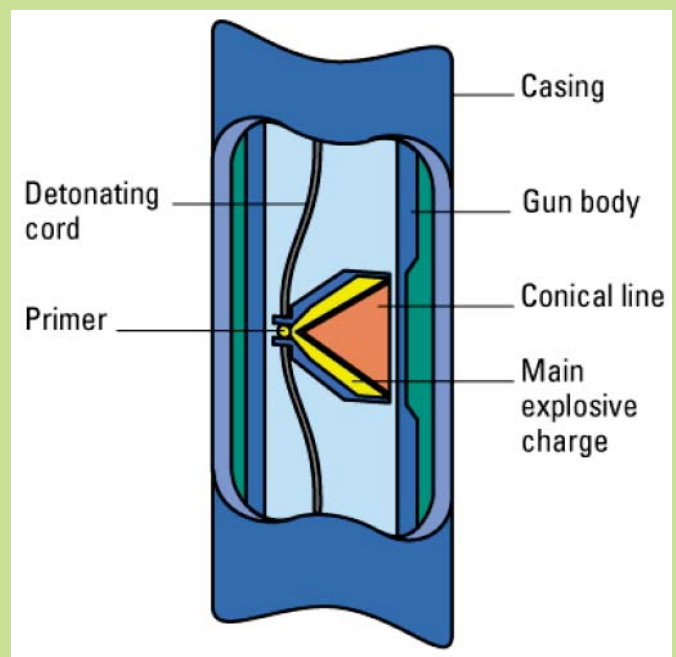

**Course Duration: (5) Days**



## R08- Reservoir Simulation

### Course Objective:

The course is designed to give an introduction to the fundamental and practical aspects of modern reservoir simulation. Particular emphasis is placed upon the available data and its integration into a data set that reflects a coherent model of the reservoir. These aspects are reinforced with some practical examples.

### Course Content:

- Buckley Leverett displacement
- Wedge's Method
- Miscible Displacement
- Frontal Stability
- **Rock-Fluid Interaction**
  - Routine and special core analysis
  - Pseudo relative permeability and capillary pressure
  - Relative permeability manipulation
  - PVT experiments, aquifer representation
- One dimensional water oil displacement
- Overview of the Modeling Process
- Two dimensional displacement
- **Fundamentals of Reservoir Simulation**
  - Conservation Laws
  - Flow Equations
  - Well and Facilities Modeling
  - Simulator Solution Procedures
  - Simulator Selection
- **Modeling Reservoir Architecture**
  - Mapping
  - Grid Preparation
  - Grid orientation and refinement
  - Model Types
  - Basic Simulator Volumetric
- **Data Preparation for a Typical Study**
- **History Matching**
  - Key History Matching Parameters
  - Evaluating the History Match
  - History Match Limitations
- Debug a problem model
- Predictions
- Validity of Model Predictions
- Well test history match and prediction for design of extended test
- Horizontal well testing
- Gas well testing
- Advanced topics in well testing.

**Course Duration: (5) Days**

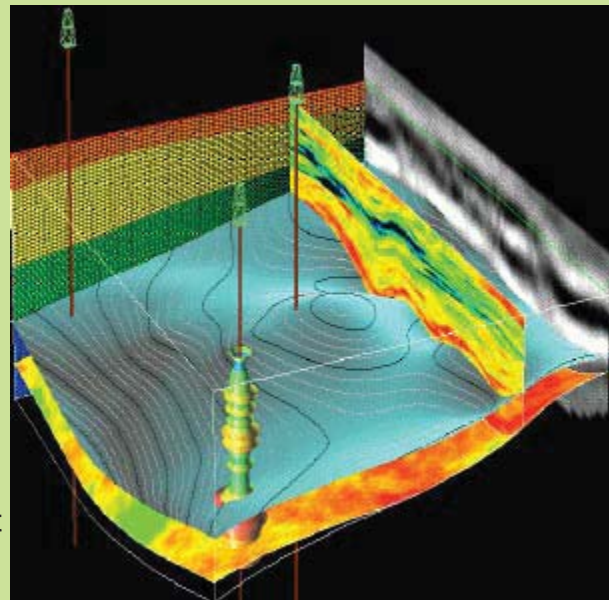



## **R09-Reservoir Management**

### **Course Objectives:**

The principles of sound reservoir management are presented with emphasis on practical applications. The significance of each component and the importance of timing and cost/benefit analysis are emphasized. Reservoir management models for optimum field development and field operating plans are analyzed. The interdisciplinary reservoir management approach shows how each technology or function contributes to the plan and how checks and balances are developed.

### **You Will Learn How To**

- Apply the principles of sound reservoir management
- Use the interdisciplinary approach to efficient reservoir management
- Include each reservoir management component and the importance of timing and cost/benefit analysis

### **Who Should Attend?**

Reservoir, production and operations engineers; geologists; geophysicists; managers; experienced technicians; and service company personnel responsible for improving the performance of petroleum reservoirs

### **Course Content:**

- Introduction
- Definition of reservoir management: an integrated, interdisciplinary team effort  
History of reservoir management, Fundamental of reservoir management, Integration of geosciences and engineering
- Reservoir Management process
  - Goal setting, planning, implementing, monitoring, and evaluating reservoir performance revision of plans and strategies , reasons for failure of reservoir management programs
  - Data acquisition, analysis and management
  - Data type, data acquisition and analysis, data validation , data application
- Reservoir performance analysis and forecast
  - Natural production mechanisms, reserves, volumetric ,method, decline curve method, material balance method, mathematical simulation
- Reservoir management economics
- Economic criteria, scenarios, economic evaluation, risk and uncertainties, Maximizing economic recovery and minimizing capital investment, risk and operating expenses
- Timing of field implementation of reservoir management plan
- Primary recovery, pressure maintenance, and secondary and tertiary recovery  
Water flood surveillance technique – A reservoir management approach  Case histories and analysis

**Course Duration: (5) Days**

## **R10-Modern Well Test Analysis**

### **Course Objective:**

- 1 Analyze all pressure transient tests which are commonly used by petroleum industry that cover oil and gas reservoirs, fractured and non-fractured reservoirs, homogenous and heterogeneous reservoirs, multilayered wells with and without cross flow, production and injection wells, and vertical, slanted, and horizontal wells.
- 2 Design pressure transient tests to achieve specific test objectives with high accuracy.
- 3 Use of pressure data in reservoir characterization and understanding the reservoir performance.

### **Who Should Attend?**

- Reservoir ,production, and wellsite engineers, technologists, technical supervisors and managers

### **Course Content:**

- Multiphase well tests.
- Perrine approach
- pressure squared approach
- Designing well tests.
- Test types
- Distinguishing characteristics
- Design consideration
- Variable dependency
- test duration
- flow rate
- Considerations.
- Advanced topics
  - o Horizontal
  - o multilayered well tests.
  - o Layered reservoir testing
  - o Horizontal wells
  - o Multiple well testing
  - o Vertical interference tests
  - o Impulse testing
  - o Closed chamber DST
  - o Water injection well testing
- Worked and field examples

**Course Duration: (5) Days**

## **R11-Hydraulic Fracturing**

### **Course Objectives:**

- Design hydraulic fracture treatments for typical field situations
- Apply the concepts of well stimulation by hydraulic fracturing to various types of reservoir conditions to optimize well productivity
- Recognize opportunities for substantial production improvement by application of effective hydraulic fracturing
- Gather pertinent well data and information to plan, design, implement, and evaluate fracturing treatments for all types of reservoirs
- Realize the strengths and limitations of hydraulic fracture theory as it relates to field applications of fracturing
- Become a participant in each fracturing treatment rather than just a technical observer

### **Course Outlines:**

#### **Day 1**

- Introduction to the fracturing process
- Fracture mechanics
- Practical fracture design

#### **Day 2**

- Fracturing fluid additives and proppant
- Strengths and limitations of fracturing applications
- Production increase

#### **Day 3**

- Factors involved in field implementation
- Acid fracturing vs. proppant fracturing

#### **Day 4**

- Frac packs
- Waterfracs
- Fracturing in horizontal wells

#### **Day 5**

- QA/QC of fracturing treatment
- Evaluation of fracturing treatment success

### **Course Duration: (5) Days**

## **R112-Reservoir Characterization**

### **Course Objects:**

The modern team approach to reservoir characterization describes productive zones more reliably through the integration of disciplines, technology and data. Increase your proven reserves, discover bypassed pay, reduce development time and costs, improve production rates, and rejuvenate old fields through the skills learned in this course. The models developed during the course are based on the application of state-of-the-art technical applications within the framework of a multi-disciplinary team approach. The course is process-based and focuses upon:

### **Who Should Attend:**

Geologists, geophysicists, reservoir engineers, production engineers, petrophysicists, exploration and production managers, team leaders, and research scientists

### **Course Outline:**

- Introduction
- Defining the business purpose: Clarifying the problem, negotiating deliverables, project management in Microsoft Project format
- Data for reservoir characterization: Sources, scale of the data/extrapolation to other areas, acquisition planning, cross-disciplinary applications/integration; quality/error minimization, data management
- Geostatistics in reservoir characterization: Applicable techniques, data viability and applicability, multiple working models, ranking of models with multi-source data
- Reservoir models: Sequence stratigraphic, geological, geophysical, reservoir engineering, flow unit, preliminary production
- Economics and risking: Volumetric, probability of success, financial returns of project
- Organizational structure: Team styles, team communications
- Assessment and evaluation: The holistic reservoir characterization model

**Course Duration: (5) Days**

## R13-Well Stimulation & Hydraulic Fracturing Technology

### Course objective

The course takes a practical approach to the applications of hydraulic fracturing. Fracturing technology is explained to show its benefits and limitations in all types of sandstone and carbonate reservoirs. Fracture modeling is used as a tool to demonstrate how modeling software can be used effectively in practical applications. Also acidizing will be considered and explained.

### Course content

- Geological review
- Basic reservoir properties
- Formation damage—how and why it happens
- **Acidizing**
  - Non-acid damage removal techniques
  - Acidizing—objectives, types, additives
  - Acidizing placement techniques and the pressure chart
  - Chemistry of sandstone acidizing
  - Chemistry of carbonate acidizing
  - Treatment diversion
  - Acid fracturing
  - Sandstone acidizing guidelines
  - Carbonate acidizing guidelines
  - Re-stimulation of acidized wells
  - QA/QC in acidizing applications
  - Quality control and safety

## **Hydraulic fracturing**

- objectives and concepts
- Hydraulic fracturing materials and their importance to job success
- Proppant transport
- The frac chart
- Pre-frac injection test analysis
- Fracture closure
- Fracture monitoring and fracture measurement
- Fluid leak-off
- Re-fracturing considerations
- Review of existing fracture modeling software
- Evaluation of post-frac well performance
- Hydraulic fracturing quality control and safety
- Fracturing in horizontal wells
- Energized fluids—application and safety

## **D-Drilling Courses**

- D01- Basic Drilling Technology
- D02- Drilling Calculations
- D03-Drilling Principle & Practice
- D04- Casing & Cementing
- D05- Drilling Problems
- D06- Stuck Pipe and Fishing Operation
- D07- Basic Direction and Horizontal Drilling
- D08- Basic Well Control
- D09- Well Operations Safety (Drilling) IWCF
- D10- Well head Maintenance
- D11-Inspection and audit for drilling rigs
- D12- Introduction to completion design
- D13-Fishing operations
- D14- Drilling Fluids
- D15- Coiled Tubing Design and Operations

## D01-Basic Drilling Technology

### Course Contents:

- Drilling Programme Approval
  - Notification  Well Site Survey And Shallow Hazard Report  Well Positioning  Notice Of Operations  Variations  Drilling Base Or Drilling Unit Design  Support Craft  Equipment And Provision  Personnel  Emergency Shutdown (Esd)
- Drilling Operations
  - General Provisions  Moving And Positioning Drilling Units  Casing And Cementing  Well Directional Survey  Blowout Prevention  Mud Programme  Formation Pressure Testing  Lost Circulation  Detection Of Over-Pressure  Suspension Of Operations  Floating Drilling Operations
- Material Handling And Disposal
  - Material Handling  Disposal Of Materials  Pollution Prevention
- Well Evaluation
  - General Provisions  Drilling Cuttings  Cores  Formation Evaluation Logging  Oil And Gas Flow Testing
- Recording And Reporting
  - Priority Reports  General Provisions  Final Drilling/Well Completion Report
- Plugging And Abandonment Of Wells
  - Responsibility To Abandon A Well  Application To Abandon A Well  Subsequent Report Of Abandonment  Permanent Abandonment  Well Suspension (Semi-Permanent  Temporary Well Suspension Well Suspension)
- Completion Operations
  - General Provision  Wellhead Equipment  Tubing Requirements  Packer Requirements  Separation Of Zones  Landing Nipple  Sub-Surface Safety Valve



- Workover Operations
  - General Requirements  Notification And Submittal Requirements  Pressure Control Requirements  Testing And Actuation Requirements  Wireline Operations  Rigging Up Or Down Of Workover Or Completion Equipment
  
- Hydrogen Sulphide Drilling
  - General Provision  Physical Properties And Toxicity Of H<sub>2</sub>s  Breathing Equipment  H<sub>2</sub>s Gas Detection Systems  Wind Direction  Ventilation Equipment  Personnel Training  Contingency Plan  Rig Equipment  Drilling Operations  Well Testing Operations
  
- Onshore Drilling Operations
  - General  Reference For Well Depth  Well Near Airport  Smoking  Fire Prevention And Safety  Engines  Surface Plug Requirements  Bop Requirements  Bop Pressure Test  Flare Pit And Vent/Bleed-Off Line  Casings
  
- Onshore Completion And Workover Operations
  - General  Sub-Surface Safety Valve  Well Stimulation  Disposal Of Produced Fluids  Onshore Wellhead Valve  Fencing And Well Security Assembly (X'mas Tree)

**Course Duration:** (5) days

## D02-Drilling Calculations

### Course Contents:

- Basic Formulas
  - Pressure Gradient
  - Hydrostatic Pressure
  - Converting Pressure Into Mud Weight
  - Specific Gravity
  - Equivalent Circulating Density
  - Maximum Allowable Mud Weight
  - Pump Output
  - Annular Velocity
  - Capacity Formulas
  - Control Drilling
  - Buoyancy Factor
  - Hydrostatic Pressure Decrease When Pulling Pipe Out Of The Hole
  - Loss Of Overbalance Due To Falling
  - Mud Level
  - Formation Temperature
  - Hydraulic Horsepower
  - Drill Pipe/Drill Collar Calculations
  - Pump Pressure/Pump Stroke Relationship Cost Per Foot
  - Temperature Conversion Formulas
- Basic Calculations
  - Volumes And Strokes
  - Slug Calculations
  - Accumulator Capacity Bulk Density
  - Of Cuttings
  - Drill String Design
  - Ton-Mile Calculations
  - Cementing Calculations
  - Weighted Cement Calculations
  - Calculations For The Number Of Sacks Of Cement Required
  - Calculations For The Number Of Feet To Be Cemented
  - Setting A Balanced Cement Plug
  - Differential Hydrostatic Pressure Between Cement In The Annulus And Mud Inside The Casing
  - Hydraulic Casing
  - Depth Of A Washout
  - Lost Returns-Loss Of Overbalance
  - Stuck Pipe Calculations
  - Calculations Required For Spotting Pills
  - Pressure Required To Break Circulation
- Drilling Fluids
  - Increase Mud Density
  - Dilution
  - Mixing Fluids Of Different Densities

- o Oil-Based Mud Calculations
- o Solids Analysis
- o Solids Fractions
- o Dilution Of Mud System
- o Displacement-Barrels Of Water/Slurry Required
- o Evaluation Of Hydrocyclone
- o Evaluation Of Centrifuge
- Pressure Control
  - o Kill Sheets And Related Calculations
  - o Prerecorded Information
  - o Kick Analysis
  - o Pressure Analysis
  - o Stripping/Snubbing Calculations
  - o Subsea Considerations
  - o Workover Operations
  - o Controlling Gas Migration
  - o Gas Lubrication
  - o Annular Stripping Procedures
- Engineering Calculations
  - o Bit Nozzle Selection-Optimized Hydraulics
  - o Hydraulics Analysis
  - o "D" Exponent
  - o Cuttings Slip Velocity
  - o Surge And Swab Pressures
  - o Equivalent Circulation Density
  - o Fracture Gradient Determination-Surface Application
  - o Fracture Gradient Determination-Subsea Application
  - o Directional Drilling Calculations
  - o Miscellaneous Equations And Calculations

**Course Duration:** (5) days

## D03-Drilling Principle & Practice

### Course Contents:

- Supervision And Reporting
  - o Responsibilities
  - o Reporting Formats
- Sequential Drilling Operations
  - o Development Well - Jack Up/Tender Assisted Drilling Unit
  - o Exploration / Appraisal Well -Floating Drilling Unit
  - o Exploration / Appraisal - Jack Up Drilling Unit
- General Drilling Practices
  - o Responsibilities
  - o Preparation
  - o General Practices
  - o Drill String Vibration
  - o Hydraulics Guidelines
  - o Rotary Bha Configurations
  - o Steerable Bha Configurations
  - o Trajectory Control
  - o Collision Avoidance
- Borehole Surveying
  - o Surveying Techniques
  - o Qa/Qc Test Of Survey Instruments
- Drilling Fluids
  - o Drilling Fluid Systems

**Course Duration:** (5) days

## **D04- Casing & Cementing**

### **Course Contents:**

- Casing Point Determination
- Casing Size Determination
- Casing Load Determination
  - o Class Project – Planning a Casing & Cementing Program for an

### **Example Well**

- Course Introduction
- Casing Design
- Class Project
- Casing Running & Landing Practices & Special Topics
- Cement Types, Additives & Testing
- Cementing Equipment
- Class Project
- Primary Cementing
- Stage Cementing
- Special Cementing Operations
  - o Squ vceze Cementing
- Class Project Conclusion

**Course Duration:** (5) days

## D05- Drilling Problems

- Bit balling
  - o Prevention
  - o Cure
- Torque and drag
  - . o Vertical holes
  - . o Deviated holes
  - . o Additives
- Differentially stuck pipe
  - . o Cause
  - . o Prevention
  - . o Cure
- Lost circulation
  - . o Prevention
  - . o Cure
  - . o Conventional materials
  - . o Special techniques
- Corrosion
  - . o Treatment
  - . o Monitoring
- Well control
  - . o Prevention
  - . o Effects of kick types
  - . o Kick and lost circulation
  - . o Losses above kick
  - . o Losses below kick
- Cementing
  - . o Hole condition
  - . o Drilling fluid condition
  - . o Drilling fluid - cement spacers
  - . o Rheology
  - . o Volume
  - . o Formulation
  - . o Cement plugs

**Course Duration:** (5) days

## D06- Stuck Pipe and Fishing Operation

- Job Planning and Record Keeping
  - o Cardinal Rules of Fishing
  - o Tally Book
  - o Arriving on Location
  - o Tally Book Abbreviations
  - o In and Out Method
  - o Leaving the Job Site upon Job
  - o Kelly Bushing (KB) Measurements Completion
- Fishing for Junk
  - o Junk or Debris Evaluation.
  - o Junk Shot
  - o Fishing Magnets
  - o Poor Boy Basket
  - o Globe Type Junk Baskets
  - o Recommended Fishing Tool Usage
  - o Reverse Circulating Junk
  - o Mills Basket
  - o Milling Rates in Surface Feet Per
  - o Bowen Full Flow Reverse Minute (SFPM) Circulating Basket
  - o Cone Buster Mills
  - o Cone Dimensions
  - o Cement Mills
- Pipe Recovery Methods
  - o Formulas o Chemical Cutter
  - o Blind Backoff
  - o Jet Cutters
  - o String Shot Backoff
  - o Super Jet Cutter
  - o Pup Joints
- Open Hole Fishing
  - o Stuck Pipe Conditions
  - o Sloughing Shale or Hole Cave –
  - o Running Wash-pipe In
  - o Differential Sticking
  - o Economics of Fishing
  - o Key Seat Sticking
  - o Before Leaving the Well Site
- Drilling Fluids
  - o Common Formation
  - o Mud Pills Problems o Circulating Time Prior to Tripping
  - o Mud Properties o Rotation and Reciprocation
  - o Vertical and Highly Deviated o Mud For Fishing Operations
  - Wells
- Fishing in Cavities
  - o Getting Wash pipe Over a Fish
  - o Other Methods To Use
  - o Overruled by Company Man
- Fishing for Parted Pipe
  - o Bottom Hole Assembly Options
  - o Releasing Overshots
  - o Screw In Sub o The Oversocket Fishing Tool

- o Overshot
- o Clulow Socket Overshot
- o What Overshot do I Need
- o Releasing Spears
- o Overshot in an Open Hole -Run Procedure
- Jarring Operations
  - o Bumper Jars (Mechanical and Lubricated)
  - o Hydraulic Up Stoke Jars
- o Mechanical Up Jar Operation
- Fishing in Lateral Wells
  - o Jars
  - o Tips on Torque Setting
- Cased Hole Fishing
  - o Mud Stuck Tubing
  - o Sand Sticking
  - o Mechanical Sticking – Stuck Packer
  - o Bowen External Cutter
  - o Bowen Internal Cutter
  - o Bowen Collar Finder
- Casing Repair
  - o Casing Failure
  - o Down hole Video
  - o Casing Swage
  - o Casing Roller
  - o Mills
- Fishing for Wire line
  - o Problems and Precautions
  - o Run in Procedures
  - o Proof of Overshot Engagement
  - o Accelerator Jars
  - o Hydro-Mechanical Dual Acting Jars
  - o Additional Jarring Procedures
  - o Retrieving Spears and Mills
  - o Parameters and Observations
  - o Packers
  - o Weatherford Washover Type Packer Milling Assembly
  - o Mechanical Sticking
  - o Lace Joint
  - o Casing Repair Tool
  - o Upper String Replacement
  - o Internal Cutters
  - o Weatherford Internal Casing Patch
  - o Side Door Overshot Procedures
  - o Fishing for Parted Wire line
  - o Double Prong Spear

**Course Duration:** (5) days



## **D07- Basic Direction and Horizontal Drilling**

### **Course Contents:**

- Applications for directional drilling
- Directional profiles
- Extended reach wells
- Survey calculations and accuracy
- Dogleg severity calculations and problems associated with doglegs
- Planning directional and horizontal wells
- Horizontal drilling methods and applications
- Logging high angle wells
- Hole-cleaning
- Types of survey instruments
- Tools used to deflect a wellbore
- Torque and drag calculations
- Cementing

**Course Duration:** (5) days

## D08- Basic Well Control

### **Course Contents:**

- Basic Well Control
  - o What is pressure
  - o What is kick
  - o What is blowout
  - o Mud hydrostatic
  - o What is formation fluid pressure
  - o What is well control
  - o Causes of kick
- Kick warning sign
  - o Pressure loss
  - o Bottom hole pressure
  - o Connection gas
- Shut in procedure
  - o Soft shut in
  - o Hard shut in
  - o Top hole
  - o diverting
- Data required before killing
  - o Shut in data
  - o Bottom hole pressure
  - o Kill mud weight

- o Gas migration
- o Circulating system

Fractures and MAASP

- o Formation testing
- o Fracture pressure
- o Leak off test

Principles of kill methods

- o Drillers method
- o Wait and weight

**Course Duration:** (5) days

## D09-Well Operations Safety(Drilling)

### Objectives :

- Incorporate the well safety services plan into the drilling plan
- Drill a well cost effectively and save time & safely manner
- Optimize the drilling operations through safety precaution
- Plan ahead the well drilling operations and HSE
- How to deal with Hot job in drilling operations
- Proactively planning optimal provision and use of resources services to maximize drilling operations and optimize conducting of work programmers and Risk Assessment
- Solve the drilling well problems proactively with Applying Safety Rules ( Loss control , HSE , Risk assessment )

### Course outline Topics

- Introduction
- Pre-test
- Drilling association well operations safety since spud in
- How oil wells are drilled safely
- Association Safety services during drilling life
  - Rig location Safety services
  - Spud in Safety services
- Drilling well operations Safety services;
  - Mud equipments
  - Mud Safety operations
  - Casing equipments
  - Casing Safety operations
  - Cementing equipment
  - Cementing Safety operations
  - Well hole problems and safety precaution
  - Association Safety services for well control
  - Risk Assessment and Loss control in drilling operations
  - HSE application in drilling operations
- Well completion with Safety services:
  - Well logging and safety services
  - Well perforation (Hot job) and Safety precaution
  - Well stimulation (Hot job) and Safety precaution

- Well testing (Hot job) and Safety precaution
- Select type of completion
- Coil tubing applications and Safety consideration
- Types of work over services and Safety procedure
- What is new in drilling and HSE technology
- Practical exercises
- Post - test

**Course Duration:** (5) days

## D10-Well head Maintenance

### Objective:

Achieve desired skills on well head operations and trouble shooting and maintenance, inspection and testing, solve problems encountered and remedial action.

X-Mass Tree Maintenance, inspection and testing

### Topics contents

- Pre-test
- Introduction to Oil & Gas industry
- Well head
  - Function of well head
  - Type of Casing
  - Types of well head assembly
  - Well head Equipments
  - Well head monitoring and data acquisition
  - Well head maintenance services
  - Well head inspection and testing
  - Work at well head with H2S PRESENCE
  - Problems and trouble shootings
- Christmas tree
  - Well head and X-Mass Tree
  - Function of X-mass tree
  - Type of X-Mass Tree
  - X-mass tree Maintenance, inspection and testing
  - X-Mass tree components
  - workshops, group work practical exercises
- Valves and Chokes
  - Types & function of valves and chokes
  - Monitor and routine check
  - Valves, chokes, Regulator and flow control devices
  - Testing, inspection & Maintenance operations

- CD – DVD Film on type of valves
- Oil well safety control
  - HS&E CONSIDERATION
  - Surface and down hole safety control system (SCSSV)
  - Control factor of oil well
  - Well head & X-mass tree safety control
  - Sampling and safety precaution
- Wire line operations
  - Wire line pressure control equipment
  - Wire line service equipment
  - Wire line down hole equipment
  - Wire line operations
  - Wire line well intervention services
- Well completion & Work over
  - Types of completion and Work over
  - Well completion equipments
  - Function of completion equipment
  - Function of Well services
  - Case studies
- Exercises
- Open form & general discussion
- Post test
- Course wrap-up
- End of course

**Course Duration:** (5) days

## **D11-Inspection & Audits for Drilling Rigs**

### **Objectives :**

- Incorporate the Rig safety services plan into the drilling plan
- Drill a well cost effectively and save time & safely manner by applying a Rig inspection as per API stander.
- Optimize the Rig drilling operations through safety precaution and periodical Auditing
- The course is designed to give delegates a basic understanding to identify and improve the knowledge of Rig inspection operations
- How to deal with Hot job utilizing the drilling Rig operations
- Achieve safely efficient operations and prevent lost time injuries, property damage & environmental accident.
- Proactively planning optimal provision and use of resources services to maximize drilling operations and optimize conducting of work programmers and Risk Assessment
- Solve the drilling Rig problems proactively with Applying Safety Rules & Inspection ( Loss control , HSE , Risk assessment )

### **Course outline Topics**

- Pre-test
- Introduction to oil gas industry
- How oil wells are drilled safely
  - Rig location Safety services
  - Spud in Safety services
- Type of Rigs
- Rig equipment components
- Auditing and inspection :-
- Hoisting Equipment
- Rotating Equipment
- Mud and circulating system equipment
- Power system equipment
- Well control and below out equipments



- Pre spud inspection list
  - Inspection and Adducting ;-
  - Drilling contractor equipment
  - Inspection Requirements:-
    - Drilling String components
    - Rig components
    - Consumable Equipment
    - Others
  - Standard Adducting:-
    - Introduction
    - Safety
    - Drilling equipments
    - Contractor's personal
    - Continuous Audit
      - Format:-
        - Rig inspection check list form
        - Daily &periodical inspection and Audit .
        - Rig inspection & Safety precaution (Hot job);-
          - Perforation
          - Acidizing
          - Fracture formation
          - Well testing
          - Kick
          - Well logging (Radio active)
            - PPE
            - Waste disposal
            - Accommodation area
            - Evacuation procedure and well abandonment
            - Load and offload
            - H2s Hazard &PRECAUTION.
            - Burning pit and flare location
            - Emergences plan and procedure
- Risk Assessment and Loss control in Rig operations.
- HSE application in drilling Rig operations
- Videos & Films CD-DVD

- Case studies (Real case Rig inspection and Audit)
- Group exercise
- General discussion
- What is new in drilling Rig and HSE technology
- Practical exercises
- Post - test

**Course Duration:** (5) days

## D12- Introduction to completion design

### Course objective

- To provide an advanced knowledge on well completion and design procedure
- Well bore treatment and monitoring
- The Table of Content as follow:-
- CHAPTER -1
  - Introduction
  - Well complex system
  - In flow and outflow system
- CHAPTER-2
  - Introduction to oil and gas well completion
  - Completion equipment and component
  - Well completion design
  - Completion fluid
  - Case studies
- CHAPTER -3
  - Production operation
  - Formation productivity
  - Stimulation
  - Perforation
  - Testing
  - Solid deposited
  - case studies
- CHAPTER-4
  - Formation damage
  - Skin factor
  - Case studies
- CHAPTER-5
  - Work over operations
  - Type of work over
  - Well performance review
  - Diagnoses and indentify well problem
  - Set up work over proposal
  - Coiled tubing application
  - work shop and case studies

- CHAPTER-6
  - Artificial lift completion
  - Type of artificial lift
  - Artificial lift design
  - Case studies

**Who should attend;**

- Petroleum eng.,
- Drilling eng.,
- Drilling supervisor production eng.
- Field staff.

**Course Duration:** (5) days

## D13- Fishing operations

### Outline program –

- Introduction
- Pre-test
- Fishing tool selection
- Classification of fishing tools
- Outside catch tools
- Inside catch tools
- Wash over and basket tools
- Fishing for Wire line
- Milling and fishing Junk
- How to select optimum fishing tools
- Case studies and examples
- Fishing Economics
- Decision Tree definition
- Decision Tree Exercise
- Optimum Fishing Time (OFT)
- How to calculate O.F.T
- Optimum Fishing Time Exercise
- Case studies
- Post-test

**Course Duration:** (5) days

## **D14- Drilling Fluids**

### **Course Outline**

To provide drilling engineers with knowledge of the basic techniques used in characterizing, selecting and preparing drilling muds and hence promote better understanding between drilling and mud engineers in view of improved control of drilling operations.

### **Content**

- FUNCTIONS OF DRILLING FLUIDS
- PHYSICAL AND RHEOLOGICAL CHARACTERISTICS OF MUDS
  - Rheological parameters.
  - Pressure losses.
- DIFFERENT TYPES OF FLUIDS
  - Composition, characteristics and conditioning of different types of mud. Water base muds.
  - Oil base muds, invert muds.
  - Aerated muds.
  - New muds, green muds.
- CASE STUDY - HOW TO DEFINE A MUD PROGRAM
  - Selection of mud.
  - Selection of parameters.
  - Consumables and economical aspects.

- MECHANICAL TREATMENTS OF FLUIDS AND MUD PITS
  - Function.
  - Selection of equipment and layout.
  - Separation ranges.
  - Overall efficiency.
- LABORATORY MUD CHECKS
  - Physical tests: density, rheology, solids.
  - Chemical tests: chloride, hardness.
  - Contamination, decontamination.

**Course Duration:** (5) days

## **D-15 Coiled Tubing Design and Operations**

### **Course Description**

- Completely revised and updated for this year, this course covers the gamut of coiled tubing applications. Economics and improvements in tools and technology have greatly increased the sphere of coiled tubing applications. Coiled tubing is the completion and remedial work string of necessity in many wells, especially for offshore, horizontal, and multilateral wells. But coiled tubing is not a panacea; there are many limitations, some obvious, some not. The questions most operators ask about this advancing technology are: What can be done with coiled tubing today that could not be done a few years ago? When should coiled tubing be used? When should coiled tubing not be used? This course is packed with the kind of information needed to answer those questions and to intelligently plan and carry out successful coiled tubing operations for specific applications. The course covers fundamental characteristics and properties of coiled tubing and how they affect well operations. Most of the course is devoted to the all-important practical applications in completions and production operations including case histories. This objective and practical course is presented with operating personnel in mind so that they are equipped to decide when, how, and whether or not to employ coiled tubing technology.

### **Course Objective**

- Describe the fundamentals of coiled tubing and specify related equipment



- Determine the parameters of coiled tubing failure and how to minimize failures
- Plan safe and effective coiled tubing operations
- Specify coiled tubing procedures and equipment for production applications
- Specify coiled tubing procedures and equipment for completion applications
- Analyze case histories of coiled tubing successes and failures

### **Who should attend?**

- Engineers and operating personnel in completion and production operations interested in learning about fundamentals of coiled tubing applications for production and completion operations. Also those with limited coiled tubing experience seeking a broader knowledge of current coiled tubing technology.

### **Course Outline**

#### 1. Coil Tubing Unit Components & Function

- ◆ Injection head
- ◆ Coiled Tubing Reel
- ◆ Power pack/Control Cabin
- ◆ Strippers
- ◆ Tandem Stripers
- ◆ Quad Blowout Preventer
- ◆ Combi and Shear/Seal BOP
- ◆ Jacking Frame

- ◆ The Coiled Tubing Unit

## 2. Coiled Pipe Specification

- ◆ Coiled Tubing Background
- ◆ Strip Bias Welding
- ◆ Taper Design
- ◆ Coiled Tubing Materials
- ◆ large-Diameter Coiled Tubing
- ◆ Internal Flash Free
- ◆ In-Line Wireline
- ◆ External Coatings
- ◆ Production String Application
- ◆ Velocity Strings
- ◆ Electrical Applications
- ◆ Subsea Flow lines
- ◆ Coiled Tubing Specifications

## 3. Working with Coil Tubing

- ◆ Standardized Procedures
- ◆ Coiled Tubing Tubing Unit Rig-Up Procedures
- ◆ Coiled Tubing BOP testing and Rig-Up
- ◆ Pre-Job Procedures

- ◆ Post-Job procedures
- ◆ Control Consoles
- ◆ Hydraulic Pressure Setting for coiled Tubing Power Packs
- ◆ Accumulators
- ◆ Use of Tools on Coiled Tubing
- ◆ Tripping Pipe
- ◆ Tubing Records
- ◆ Calculations of Displacement and Capacity
- ◆ Coiled Tubing failures and Pin Holes
- ◆ Field Welding and Repair of Coiled Tubing
- ◆ Stuck Coiled Tubing
- ◆ Runaway Hang Off's
- ◆ Purging of Hazardous Material
- ◆ Personal of Hazardous Equipment
- ◆ Safety Equipment on Unit
- ◆ Personal Protective safety Equipment Requirement
- ◆ Safety Procedures for H2S
- ◆ Emergency Shutdown, BOP Drills, BOP Pressure tests and Actuation
- ◆ Coiled Tubing Operations at Night
- ◆ Several Weather/Wind/Lightning

- ◆ Operating in Extreme Temperatures
- ◆ Communications Systems
- ◆ Pumps, tank and Gas Busters, Return Lines and Chokes
- ◆ Use of Grains for Coiled Tubing Operations
- ◆ Elastomeric Selection for Coiled Tubing
- ◆ rental Equipment
- ◆ Nitrogen Safety and Rig-Up
- ◆ Job Site Procedures
- ◆ Working Above ground

#### 4. CTU Heavy Duty Tool String

- ◆ SPE Cooperation and Utilization
- ◆ Coiled Tubing Service Tools
- ◆ Hydraulic jars
- ◆ Knuckle Joints
- ◆ Accelerators
- ◆ Inflatable Packer
- ◆ Tubing Connectors F/Service Tools
- ◆ Tubing Connectors F/Completions
- ◆ Hydraulic Disconnect Tool
- ◆ Back Pressure Valve

## 5. CTU Packer Application

- ◆ Why Run A Packer?
- ◆ Inflatable packer
- ◆ Technical Information
- ◆ Coiled Tubing Products
- ◆ Recommended Procedures
- ◆ Inflatable Packers
- ◆ Thru-Tubing Fishing Services

## 6. Wellbore Cleanout

- ◆ Sand Washing with Coiled Tubing
- ◆ Sand Washing with Water
- ◆ Sand Washing with Nitrified water
- ◆ Sand Washing with foam
- ◆ Example of sand Washing Procedure
- ◆ Cleaning Out With a Down hole Motor
- ◆ Jetting with Coiled Tubing
- ◆ Jetting for Production
- ◆ Reduction of Hydrostatic Head for perforating
- ◆ Back flushing Disposal and Injection Wells
- ◆ Jetting for Zone Evaluation

- ◆ Paraffin and Salt Removal Using Coiled Tubing
- ◆ Paraffin removal Using Coiled Tubing and Hot Oil
- ◆ paraffin and Salt removal Using Coiled Tubing and Hot water
- ◆ Paraffin removal using Coiled Tubing and Chemicals  
Asphaltenes
- ◆ Asphalting removal

## 7. Formation Stimulation

- ◆ Introduction
- ◆ Chemical Stimulation
- ◆ Completion Types
- ◆ Acids
- ◆ General Acid Treatment Schedule
- ◆ General Acid Placement Technique
- ◆ Specialty Stimulation

## 8. Cementing

- ◆ Introduction
- ◆ Cement Design Specifications
- ◆ Cement Techniques

## 9. CTU Drilling

Milling-Drilling-and Fishing

- ◆ Rotational Drilling with Coiled Tubing

- ◆ Jet Drilling with Coiled Tubing

- ◆ Otis Jet Drill Head

## 10. CTU Electric Line Services

(Conveyed Services)

- ◆ Introduction

- ◆ Wireline Equipped Coiled Tubing Logging and Performing Services

- ◆ Coiled Tubing Logging and Performing

**Course Duration:** (5) days

## **MT-Material Coding Courses:**

MT01- Modern Coding Systems Program Level (I)

MT02- Modern Coding Systems Program Level (II)

MT03- Modern Coding Systems Program Level (III)

MT04- Modern Coding Systems Program (Practices)

MT05- Coding Systems Program for Requesting Departments

MT06- Coding Systems Program for Advanced Level

MT07- Coding Systems Program for Store Keepers

MT08- Coding Systems Program to serve the maintenance programs



## **MT01-Modern Coding Systems Program**

### **Level (I)**

#### **Objectives:**

Explain the program, updates, computerization, and ideal usage of modern coding systems applied within the majority of the petroleum companies.

#### **Duration**

20 hours ( 4 hours per day for five days).

#### **Who Should Attend**

Supervisors & specialists in the various fields of the Material General Department.

#### **Course outlines**

1. Material & Equipment types & their Coding - MESC ( Shell Co.)
2. Catalogues Management Tool - CMT (Shell Co.)
3. Standardization & Coding ( Petromaint Co.) - APMSC
4. Coding Systems Computerization

## **MT02-Modern Coding Systems Program**

### **Level (II)**

#### **Objectives:**

Explain the purposed goals of modern coding systems in the economically Material Department performance and its usage in the material description, coding & Stock Control.

#### **Duration**

20 hours ( 4 hours per day for five days).

#### **Who Should Attend**

Supervisors & specialists in the various fields of the Material General Department.

#### **Course outlines**

1. Role of Modern Coding Systems Program in achieving of Material Department goals.
2. Providing of Information
3. Coding of Diesel Spare Parts
4. Role of Modern Coding Systems Program in the field of Stock Control

## **MT03-Modern Coding Systems Program**

### **Level (III)**

#### **Objectives:**

- Explain the know-how of definition & differentiation for certain selected types
- Significance of standardization for suppliers & users of Material & Equipment.
- Study of some Technical Abbreviations & terminologies
- Analytic review for coding & coding numbers creation of Spare parts

#### **Duration**

20 hours ( 4 hours per day for five days).

#### **Who Should Attend**

Supervisors & specialists in the various fields of the Material General Department.

#### **Course outlines**

1. Role of Modern Coding Systems Program in definition & differentiation for certain selected types
2. Standardization & Coordination between the industrial companies
3. Study of some Technical Abbreviations & terminologies
4. Analytic review for coding & coding numbers creation of Spare parts related to Mechanical leakage resistance

## **MT04-Modern Coding Systems Program**

### **(Practices)**

#### **Objectives:**

- Explain coding of spare parts, mechanisms & its attachments and spare parts Exchangeability

#### **Duration**

20 hours ( 4 hours per day for five days).

#### **Who Should Attend**

Supervisors & specialists in the various fields of the Material General Department.

#### **Course Outline**

1. Turbines spare parts coding
2. Mechanisms & its attachments coding
3. Vehicles spare parts coding
4. spare parts Exchangeability

## **MT05-Coding Systems Program for Requesting Departments**

### **Objectives:**

- Coding System utilization methods in case of Material requisition, issue, circulation, study & usage with the alternate spare parts

### **Duration**

20 hours ( 4 hours per day for five days).

### **Who Should Attend**

Engineers, technicians and administrator in the various fields of the company

### **Course outlines**

1. Material standardization & description
2. Searching Methods for material & spare parts
3. Alternates & Comparison
4. Material Circulation

## **MT06-Coding Systems Program for Advanced Level**

### **Objectives:**

- Modern Method for import direction and identification of supplying resources through exchangeability program for spare parts and study for suppliers technical proposals as well as economically stock activation

### **Duration**

20 hours ( 4 hours per day for five days).

### **Who Should Attend**

Engineers, technicians and specialists assigned to study the suppliers technical proposals and stock activation.

### **Course outlines**

1. Import direction and identification of supplying resources .
2. Exchangeability program for spare parts .
3. Technical study for suppliers spare parts lists.
4. Stagnant Stock activation economically

## **MT07-Coding Systems Program for Store Keepers**

### **Objectives:**

- Illustrative explanation & usage of coding systems in material circulation and activation of stagnant material and methods of mistakes exploration & correction

### **Duration**

20 hours ( 4 hours per day for five days).

### **Who Should Attend**

Supervisors, store keepers, helpers & Store Clerk

### **Course out lines**

1. Standardization and material specification
2. Material Coding
3. Coding Role in Receiving, Storage & Issuance material
4. Coding Role in Storage & preservation of material.

**MT08-Coding Systems Program**  
**to serve the maintenance programs**

**Objectives:**

- Methods of coding systems advantage when preparing maintenance systems & overhauling, required quantities and achieving economical usefulness of requisition.

**Duration**

20 hours ( 4 hours per day for five days).

**Who Should Attend**

Maintenance Engineers

**Course out lines**

1. Standardization and material specification
2. Equipment types & typical specification
3. Exchangeability of Spare parts
4. Economic Advantage Study of spare parts requisition / Replacement & Revamping



TC05-Planned Maintenance of Telecommunication systems

TC06-Mastering in Optical Fiber Systems and Cables

TC07- PABX Systems

TC08- اساسيات الاتصالات السلكيه واللاسلكيه-(I)

# **TC01-Optical Fiber Systems and Cables**

## **Description:**

The fiber optic systems are nowadays commonly used in communication systems. This can be used for high data rate, non-interfered and secured communications.

## **Objectives:**

This course gives the ability to:-

- Know fundamental knowledge of fiber optic theory, codes, standards and practices.
- Know the Fiber optic cables specifications and components.
- Understand and deal with [Optical add/drop multiplexer](#).
- Know the Fiber optic components (SONET, SDH...)
- How to build ring protection and redundancy systems.
- Have splicing practices.
- Understand and deal with the Fiber optic test equipments.
- Understand and differentiate between different fiber optic manufacturing.

## **Who Should Attend:**

Excellent for those who install or for those who supervise the design or installation of fiber optic systems.

## **Duration:**

5 days (20 hrs)

## **Course Outlines:**

- Introduction and history of optical fiber
- Single mode fiber optic
- Multimode fiber optic
- Fiber optic connectors
- Fiber optic patch panels
- Fiber optic test equipments
- Fiber optic splicing
- Fiber optic tools
- Fiber optic termination
- Integrated SDH coverage
- WDM and DWDM
- Architecture and protocols
- Basic and advanced overhead and payload pointers

- **Network equipment**
- **SONET/SDH**
- **Loop ring protection and redundancy**
- **Use SONET/SDH to connect routers for data applications (IP over SONET)**
- **Network Management Systems (NMS)**
- **online OTDR systems**

# **TC02-Wireless Communication Systems**

## **Description:**

Mobile communication is, by any measure, the fastest growing segment of the communications industry. Information technology (IT), SCADA, DCS and internet commonly depends on wireless communication networks.

## **Objectives:**

This course gives the ability to:-

- Understand and deal with wireless communication.
- Design, install and deal with the different commercial types of the wireless communication systems in the world.
- How to implement the wireless systems in the industries.
- Know the different types of wireless communications and how, where and when to use.

## **Who Should Attend:**

Telecommunication, Control, instrumentation and Scada engineers

## **Duration:**

5 days (20 hrs)

## **Course Outlines:**

- Radio Signaling Fundamentals
- Spectrum Use, Management and Availability
- Digital communication fundamentals
- Conventional and trunking systems
- Network Technologies, Architectures.
- The different wireless generations & Standards
- Terminals & Phones
- Coverage area and domain size
- New Alternative Wireless Voice and Data Networks
- Analysis of the Mobile and Cellular Industry
- How and why GSM, WCDMA, ...
- How and why Wi-Fi/WiMAX, Zigbee, ....
- Unlicensed Mobile Access (UMA)
- The Future of Mobile Communications

- **Implementation in DCS and SCADA systems**
- **Implementation in Networking**
- **Implementation in Instrumentation**
- **Network Management Systems (NMS)**

# **TC03-Microwave Communications**

## **Description:**

The microwave communication systems are commonly used in our life for voice and data communication in different ways.

## **Objectives:**

This course gives the ability to:-

- Understand the microwave communication.
- How to make the path loss estimation.
- How to make site survey.
- Design and install the different types of the microwave communications systems.
- Have a lot of knowledge and practical information in microwave communications design, installation, operation, and maintenance.
- Understand the smart antennas and how to choose.
- Understand the point to point systems
- Understand the point to mutli-point systems
- Compare between the conventional and UWB systems.

## **Who Should Attend:**

Telecommunication and Scada engineers

## **Duration:**

5 days (20 hrs)

## **Course Outlines:**

- **Microwave systems and Antennas**
- **Digital communication fundamentals**
- **Microwave circuits design**

- MUX , E1 and mux plan
- Different types of voice and data channels
- Network Management Systems (NMS)
- Microwave cables and wave guides
- Duplexers
- Combiners and splitters
- Path loss calculations
- Site survey
- System design and implementation
- Antennas and wave propagation
- Antennas installations and practices
- Smart antennas and adaptive antennas
- MIMO technology
- UWB, OFDM communications
- Space and frequency diversity
- Point to Point systems
- Point to Multi-point systems

# **TC04-Mastering in Microwave Communications**

## **Description:**

The microwave communication systems are commonly used in our life for voice and data communication in different ways. To have a reliable system, you should search for the newest and the best with respect to your budget, design and install under the international recommendations to be as a guide for you.

## **Objectives:**

This course gives the ability to:-

- Understand the microwave communication.
- Know the newest smart antennas and how to choose.
- Know the newest point to point systems
- Know the newest point to mutli-point systems
- Know the OFDM technology
- Compare between the conventional and UWB systems and what to choose.
- How to organize mux plan.
- How to make the path loss estimation.
- How to make site survey.
- How to prepare specifications and evaluate offers.
- How to make installations and commissioning.
- Understand IEEE and ITU standards.
- Design and install the different types of the microwave communications systems.
- Have a lot of knowledge and practical information in microwave communications design, installation under the ITU recommendations.
- Have a lot of knowledge and practical information in microwave communications design, installation under Osha regulations and other safety regulations.



## **Who Should Attend:**

Telecommunication and Scada engineers

## **Duration:**

5 days (20 hrs)

## **Course Outlines:**

- Microwave systems and Antennas
- Digital communication fundamentals
- Microwave circuits design
- MUX , E1 and mux plan
- Different types of voice and data channels
- Network Management Systems (NMS)
- Microwave cables and wave guides installations
- Path loss calculations
- Site survey
- System design and implementation
- Antennas installations and practices
- Smart antennas and adaptive antennas
- MIMO technology
- UWB, OFDM communications
- Space and frequency diversity
- What is the new in Point to Point systems?
- What is the new in Point to Multi-point systems?
- ITU and IEEE standards
- OSHA regulations in communications systems installations.

# **TC05-Planned Maintenance of Telecommunication systems**

## **Description:**

This course will introduce the planned maintenance programs to all engineers working in telecommunication applications and show some of different systems to select the suitable one for your industry.

## **Objectives:**

This course gives the ability to:

- Increase the life time of plant components
- Safety satisfaction
- Design and implement the maintenance rules
- Minimize the operation and maintenance cost
- Build the human skills
- Overview of CMMS

## **Who Should Attend:**

Telecommunication, scada and maintenance engineers and supervisors

## **Duration:**

5 days (20 hrs)

## **Course Outlines:**

- Introduction
- Main benefits and characteristics planned maintenance
- Introduction to control system maintenance
- Maintenance managements
- Maintenance engineering
- Service control maintenance
- Configuration and programming
- Calibration
- Tuning details and examples
- Maintenance troubleshooting and safety

# **TC06-Mastering in Optical Fiber Systems and Cables**

## **Description:**

The fiber optic systems are nowadays commonly used in communication systems. This can be used for high data rate, non-interfered and secured communications. To have a reliable system, you should search for the newest and the best with respect to your budget, design and install under the international recommendations to be as a guide for you.

## **Objectives:**

This course gives the ability to:-

- Know fundamental knowledge of fiber optic theory, codes, standards and practices.
- Know the Fiber optic cables specifications and components.
- Understand and deal with [Optical add/drop multiplexer](#).
- Know the Fiber optic components (SONET, SDH...)
- How to build ring protection and redundancy systems.
- Understand and deal with the Fiber optic test equipments.
- Understand and deal with the different newest networks devices
- Have a lot of knowledge and practical information in network design and installations
- Have more experience in trouble shooting.
- How to calculate the traffic and network capacity.
- How to make site survey.
  
- How to prepare specifications and evaluate offers.
  
- How to make installations and commissioning.
- Understand IEEE and ITU standards.
- Have a lot of knowledge and practical information in system design, installation under the (ITU, Fujikura ...) recommendations.
- How to install the F.O cables and splicing under the international codes and recommendations.
- Have a lot of knowledge and practical information in system design, installation under the Osha regulations and other safety regulations.

## **Who Should Attend:**

Excellent for those who install or for those who supervise the design or installation of fiber optic systems.

## **Duration:**

5 days (20 hrs)

## **Course Outlines:**

- Introduction and history of optical fiber
- Single mode fiber optic
- Multimode fiber optic
- Fiber optic test equipments
- Fiber optic splicing
- Fiber optic tools
- Integrated SDH coverage
- MUX plan
- WDM and DWDM
- SONET/SDH
- Loop ring protection and redundancy
- Use SONET/SDH to connect routers for data applications (IP over SONET)
- Network Management Systems (NMS)
- online OTDR systems
- Network equipments design and choosing
- Installations and commissioning rules
- ITU and IEEE standards in design and installations
- Safety regulation in installations and design

## **TC07-PABX Systems**

### **Description:**

This course is intended to extend the participants basic knowledge of the PABX Systems so they will be able to plan, program and maintain the PABX.

### **Objectives:**

This course gives the ability to:

- Understand and deal with PABX components
- Understand and program with PABX software
- Know the different features and class of service
- Understand and deal with VoIP PABX components

### **Who Should Attend:**

Telecommunication engineers, senior technicians and supervisors

### **Duration:**

5 days (20 hrs)

### **Course Outlines:**

- Terminology and basic PABX principles
- PABX hardware ie. Basic circuit cards & various devices
- Basic principles to PABX programming
- Assignment of stations (Analog, IP and digital)
- Service Restriction Class
- Class of service – station & trunk
- Speed dial numbers
- Call pickup groups
- Virtual numbers
- Add on module
- PABX system backup
- 30-channel Digital Tielines
- Comparison with Analog Tielines
- Network design including Analog/Digital Tielines
- Programming and Testing of Network

## اساسيات الاتصالات اللاسلكية و السلكية (I) TC08

### **Description:**

The wireless communication systems are commonly used in our life for voice and data communication in different ways.

### **Objectives:**

This course gives the ability to:-

- Understand the wired and wireless communication systems.
- Have a lot of knowledge and practical information in microwave communications.
- Have a lot of knowledge and practical information in wireless communications.
- Have a lot of knowledge and practical information in fiber optic communications.
- Have a lot of knowledge and practical information in PABX.
- Understand the point to point systems.
- Understand the point to mutli-point systems.
- Know what and how to use Measurement equipments.

### **Who Should Attend:**

Telecommunication technicians

### **Duration:**

5 days (20 hrs)

### **Course Outlines:**

- Radio Signaling Fundamentals
- Spectrum Use, Management and Availability
- Conventional and trunking systems
- Microwave systems and Antennas
- Digital communication fundamentals
- Different types of voice and data channels
- Network Management Systems (NMS)
- Microwave cables and wave guides

- Point to Point systems
- Point to Multi-point systems
- The measuring equipments
- Introduction and history of optical fiber
- Single mode fiber optic
- Multimode fiber optic
- Fiber optic connectors
- Fiber optic patch panels
- Fiber optic test equipments
- online OTDR systems
- Introduction of PABX
- PABX boards
- MDF types and installation

## اساسيات الاتصالات اللاسلكية و السلكية (II) TC09

### **Description:**

The wireless communication systems are commonly used in our life for voice and data communication in different ways.

### **Objectives:**

This course gives the ability to:-

- Have a lot of knowledge and practical information in microwave communications for installation, operation, and maintenance.
- Have a lot of knowledge and practical information in wireless communications for installation, operation, and maintenance.
- Have a lot of knowledge and practical information in fiber optic communications for installation, operation, and maintenance.
- Have a lot of knowledge and practical information in PABX for installation, operation, and maintenance.
- Know the basics of antennas and how to install.

### **Who Should Attend:**

Telecommunication technicians

### **Duration:**

5 days (20 hrs)

### **Course Outlines:**

- Microwave circuits design
- MUX , E1 and mux plan
- Different types of voice and data channels
- Duplexers
- Combiners and splitters
- Path loss calculations
- Site survey



- Antennas and wave propagation
- Antennas installations and practices
- Smart antennas and adaptive antennas
- Space and frequency diversity
- The different wireless generations & Standards
- Coverage area and domain size
- Analysis of the Mobile and Cellular Industry
- How and why GSM, WCDMA, ...
- How and why Wi-Fi/WiMAX, Zigbee, ....
- Unlicensed Mobile Access (UMA)
- The Future of Mobile Communications
- Implementation in DCS and SCADA systems
- Implementation in Networking
- Implementation in Instrumentation
- Fiber optic splicing
- Fiber optic tools
- Fiber optic termination
- Integrated SDH coverage
- SONET/SDH
- Loop ring protection and redundancy

# **TC10-Biological Electromagnetic Effects and Safety Limits**

## **Description:**

Many of the existing safety guidelines governing microwave/RF/ELF, controlled/uncontrolled exposure are based on intensity of exposure that produces heating of tissues due to energy absorption leading to temperature rise and manifested as thermal effects. On the other hand, though the human body could compensate for and handle the extra energy load through the thermoregulatory mechanisms without obvious increase in temperature, stress could still develop.

## **Objectives:**

This course helps to:-

- Understand the electromagnetic waves.
- Know the different biological electromagnetic effects.
- Know the bad and good effects of electromagnetic waves.
- How to deal with the different effects and the safety precautions.
- Know the international standards of electromagnetic waves.
- How to eliminate the bad effects of electromagnetic waves.
- 

## **Who Should Attend:**

This course is design for all people concerning with the electromagnetic waves such as telecommunication engineers and technicians, HSE and OHSAS responsible, etc.

## **Duration:**

5 days (20 hrs)

## **Course Outlines:**

- Electromagnetics Introduction
- Ionoized and non ionized radiations
- Radio wave Maximum Permissible Exposure
- IEEE, FCC Recommendations
- Power Density and time-averaged values
- Specific Absorption Rate (SAR)

- **Base station and Mobile sets Radiations**
- **The Precaution for the employees in installation and maintenance**
- **Environmental Protection Agency-EPA and FCC**
- **OSHA Recommendations**
- **National Law for Radiation Exposure**
- **Earthing and Electrostatic discharging**

Alexandria: 51 Wengat st., Farah Tower - Bolkly  
Phone: 03 5233641 - Fax: 03 5233642

[www.petromaint.net](http://www.petromaint.net)